

STATE OF NORTH CAROLINA
DEPARTMENT OF TRANSPORTATION
RALEIGH, N.C.

C203725

CONTRACT AND
CONTRACT BONDS

FOR CONTRACT NO. C203725

WBS 34845.3.3 STATE FUNDED

T.I.P NO. U-2707

COUNTY OF FORSYTH

THIS IS THE ROADWAY CONTRACT

ROUTE NUMBER SR 3000 LENGTH 2.093 MILES

LOCATION SR-3000 (IDOLS RD) FROM SR-2999 (HAMPTON RD) TO US-158
(CLEMMONS RD).

CONTRACTOR SMITH-ROWE, LLC

ADDRESS 639 OLD US 52 SOUTH
MOUNT AIRY, NC 27030

BIDS OPENED APRIL 19, 2016

CONTRACT EXECUTION 5/16/2016

STATE OF NORTH CAROLINA
DEPARTMENT OF TRANSPORTATION
RALEIGH, N.C.

PROPOSAL

INCLUDES ADDENDUM No. 1 DATED 04-08-16

DATE AND TIME OF BID OPENING: **APRIL 19, 2016 AT 2:00 PM**

CONTRACT ID C203725
WBS 34845.3.3

FEDERAL-AID NO. STATE FUNDED

COUNTY FORSYTH

T.I.P. NO. U-2707

MILES 2.093

ROUTE NO. SR 3000

LOCATION SR-3000 (IDOLS RD) FROM SR-2999 (HAMPTON RD) TO US-158
(CLEMMONS RD).

TYPE OF WORK GRADING, DRAINAGE, PAVING, SIGNALS, AND STRUCTURES.

NOTICE:

ALL BIDDERS SHALL COMPLY WITH ALL APPLICABLE LAWS REGULATING THE PRACTICE OF GENERAL CONTRACTING AS CONTAINED IN CHAPTER 87 OF THE GENERAL STATUTES OF NORTH CAROLINA WHICH REQUIRES THE BIDDER TO BE LICENSED BY THE N.C. LICENSING BOARD FOR CONTRACTORS WHEN BIDDING ON ANY NON-FEDERAL AID PROJECT WHERE THE BID IS \$30,000 OR MORE, EXCEPT FOR CERTAIN SPECIALTY WORK AS DETERMINED BY THE LICENSING BOARD. BIDDERS SHALL ALSO COMPLY WITH ALL OTHER APPLICABLE LAWS REGULATING THE PRACTICES OF ELECTRICAL, PLUMBING, HEATING AND AIR CONDITIONING AND REFRIGERATION CONTRACTING AS CONTAINED IN CHAPTER 87 OF THE GENERAL STATUTES OF NORTH CAROLINA. NOTWITHSTANDING THESE LIMITATIONS ON BIDDING, THE BIDDER WHO IS AWARDED ANY FEDERAL - AID FUNDED PROJECT SHALL COMPLY WITH CHAPTER 87 OF THE GENERAL STATUTES OF NORTH CAROLINA FOR LICENSING REQUIREMENTS WITHIN 60 CALENDAR DAYS OF BID OPENING.

BIDS WILL BE RECEIVED AS SHOWN BELOW:

THIS IS A ROADWAY PROPOSAL

5% BID BOND OR BID DEPOSIT REQUIRED

**PROPOSAL FOR THE CONSTRUCTION OF
CONTRACT No. C203725 IN FORSYTH COUNTY, NORTH CAROLINA**

Date _____ 20 _____

**DEPARTMENT OF TRANSPORTATION,
RALEIGH, NORTH CAROLINA**

The Bidder has carefully examined the location of the proposed work to be known as Contract No. C203725; has carefully examined the plans and specifications, which are acknowledged to be part of the proposal, the special provisions, the proposal, the form of contract, and the forms of contract payment bond and contract performance bond; and thoroughly understands the stipulations, requirements and provisions. The undersigned bidder agrees to be bound upon his execution of the bid and subsequent award to him by the Board of Transportation in accordance with this proposal to provide the necessary contract payment bond and contract performance bond within fourteen days after the written notice of award is received by him. The undersigned Bidder further agrees to provide all necessary machinery, tools, labor, and other means of construction; and to do all the work and to furnish all materials, except as otherwise noted, necessary to perform and complete the said contract in accordance with *the 2012 Standard Specifications for Roads and Structures* by the dates(s) specified in the Project Special Provisions and in accordance with the requirements of the Engineer, and at the unit or lump sum prices, as the case may be, for the various items given on the sheets contained herein.

The Bidder shall provide and furnish all the materials, machinery, implements, appliances and tools, and perform the work and required labor to construct and complete State Highway Contract No. C203725 in Forsyth County, for the unit or lump sum prices, as the case may be, bid by the Bidder in his bid and according to the proposal, plans, and specifications prepared by said Department, which proposal, plans, and specifications show the details covering this project, and hereby become a part of this contract.

The published volume entitled *North Carolina Department of Transportation, Raleigh, Standard Specifications for Roads and Structures, January 2012* with all amendments and supplements thereto, is by reference incorporated into and made a part of this contract; that, except as herein modified, all the construction and work included in this contract is to be done in accordance with the specifications contained in said volume, and amendments and supplements thereto, under the direction of the Engineer.

If the proposal is accepted and the award is made, the contract is valid only when signed either by the Contract Officer or such other person as may be designated by the Secretary to sign for the Department of Transportation. The conditions and provisions herein cannot be changed except over the signature of the said Contract Officer.

The quantities shown in the itemized proposal for the project are considered to be approximate only and are given as the basis for comparison of bids. The Department of Transportation may increase or decrease the quantity of any item or portion of the work as may be deemed necessary or expedient.

An increase or decrease in the quantity of an item will not be regarded as sufficient ground for an increase or decrease in the unit prices, nor in the time allowed for the completion of the work, except as provided for the contract.

Accompanying this bid is a bid bond secured by a corporate surety, or certified check payable to the order of the Department of Transportation, for five percent of the total bid price, which deposit is to be forfeited as liquidated damages in case this bid is accepted and the Bidder shall fail to provide the required payment and performance bonds with the Department of Transportation, under the condition of this proposal, within 14 calendar days after the written notice of award is received by him, as provided in the *Standard Specifications*; otherwise said deposit will be returned to the Bidder.



State Contract Officer

DocuSigned by:

A7079FC32A09478...

4/8/2016

TABLE OF CONTENTS

COVER SHEET
PROPOSAL SHEET

PROJECT SPECIAL PROVISIONS

CONTRACT TIME AND LIQUIDATED DAMAGES: G-1
 INTERMEDIATE CONTRACT TIME NUMBER 1 INCENTIVE AND DISINCENTIVE: .. G-1
 INTERMEDIATE CONTRACT TIME NUMBER 2 AND LIQUIDATED DAMAGES: G-2
 PERMANENT VEGETATION ESTABLISHMENT:..... G-3
 DELAY IN RIGHT OF ENTRY: G-4
 MAJOR CONTRACT ITEMS: G-5
 SPECIALTY ITEMS:..... G-5
 FUEL PRICE ADJUSTMENT: G-5
 SCHEDULE OF ESTIMATED COMPLETION PROGRESS:..... G-6
 MINORITY BUSINESS ENTERPRISE AND WOMEN BUSINESS ENTERPRISE: G-6
 CONTRACTOR'S LICENSE REQUIREMENTS: G-21
 SUBSURFACE INFORMATION:..... G-21
 LOCATING EXISTING UNDERGROUND UTILITIES:..... G-22
 VALUE ENGINEERING PROPOSAL: G-22
 RESOURCE CONSERVATION AND ENV. SUSTAINABLE PRACTICES:..... G-23
 DOMESTIC STEEL: G-24
 MAINTENANCE OF THE PROJECT: G-24
 TWELVE MONTH GUARANTEE: G-25
 OUTSOURCING OUTSIDE THE USA: G-25
 GIFTS FROM VENDORS AND CONTRACTORS: G-26
 LIABILITY INSURANCE:..... G-26
 EROSION AND SEDIMENT CONTROL/STORMWATER CERTIFICATION: G-26
 PROCEDURE FOR MONITORING BORROW PIT DISCHARGE:..... G-32
 EMPLOYMENT:..... G-33
 STATE HIGHWAY ADMINISTRATOR TITLE CHANGE:..... G-34
 SUBLETTING OF CONTRACT: G-34

ROADWAY..... R-1

STANDARD SPECIAL PROVISIONS

AVAILABILITY FUNDS – TERMINATION OF CONTRACTSSSP-1
 NCDOT GENERAL SEED SPECIFICATION FOR SEED QUALITYSSP-2
 ERRATA.....SSP-5
 PLANT AND PEST QUARANTINESSSP-7
 MINIMUM WAGESSSP-8
 AWARD OF CONTRACT.....SSP-9
 ON-THE-JOB TRAINING.....SSP-14
 NCDENR NAME CHANGE..... SSP-17

UNIT PROJECT SPECIAL PROVISIONS

GEOTECHNICAL.....GT-0.1
 TRAFFIC CONTROL TC-1
 UTILITY CONSTRUCTION.....UC-1
 UTILITY BY OTHERS.....UBO-1
 EROSION CONTROL EC-1
 TRAFFIC SIGNALSTS-1
 STRUCTURE / CULVERTSST-1

PERMITS P-1

PROPOSAL ITEM SHEET

ITEM SHEET(S) (TAN SHEETS)

PROJECT SPECIAL PROVISIONS**GENERAL****CONTRACT TIME AND LIQUIDATED DAMAGES:**

(8-15-00) (Rev. 12-18-07)

108

SP1 G07 A

The date of availability for this contract is **June 1, 2016**, except that work in jurisdictional waters and wetlands shall not begin until a meeting between the DOT, Regulatory Agencies, and the Contractor is held as stipulated in the permits contained elsewhere in this proposal. This delay in availability has been considered in determining the contract time for this project.

The completion date for this contract is **April 30, 2018**.

Except where otherwise provided by the contract, observation periods required by the contract will not be a part of the work to be completed by the completion date and/or intermediate contract times stated in the contract. The acceptable completion of the observation periods that extend beyond the final completion date shall be a part of the work covered by the performance and payment bonds.

The liquidated damages for this contract are **Two Hundred Dollars (\$ 200.00)** per calendar day. These liquidated damages will not be cumulative with any liquidated damages which may become chargeable under Intermediate Contract Time Number 1.

INTERMEDIATE CONTRACT TIME NUMBER 1 INCENTIVE AND DISINCENTIVE:

(3-27-07) (Rev. 1-17-12)

108

SPI 1-6

Except for that work required under the Project Special Provisions entitled *Planting, Reforestation and/or Permanent Vegetation Establishment*, included elsewhere in this proposal the Contractor shall complete all work included in this contract and shall place and maintain traffic on same.

The date of availability for this intermediate contract time is **June 1, 2016**.

The completion date for this intermediate contract time is **November 1, 2017**.

It is mutually agreed that time is of the essence in completing Intermediate Contract Time Number 1 and opening same to traffic. It is further mutually agreed a delay in completing this work will result in damage due to increased engineering and inspection costs to the Department of Transportation, great hardship to the general public, public inconvenience, obstruction of traffic, interference with business, and increased cost of maintaining traffic.

By reason of the necessity of expeditious completion of the work of Intermediate Contract Time Number 1 and placing and maintaining traffic on same, it is mutually agreed the Contractor shall receive an incentive payment of **Two Thousand Dollars (\$2,000.00)** per calendar day for each day prior to **November 1, 2017** that this work is completed. Incentive payment shall be limited to a maximum of **One Hundred Twenty Four Thousand Dollars (\$124,000.00)**. No incentive

payment shall be allowed for any calendar day after **November 1, 2017** that this work remains incomplete. This **November 1, 2017** date shall be utilized in determining incentive payments and it shall not be revised for any reason whatsoever. Incentive payment determined to be due the Contractor shall be paid by the Department within forty-five (45) calendar days after completion of all work. No incentive payment shall be allowed if the contract is terminated under the provisions of Article 108-13 of the *2012 Standard Specifications*.

Disincentive of **Two Thousand Dollars (\$2,000.00)** per calendar day shall be assessed the Contractor for each day beyond the completion date for Intermediate Contract Time Number 1 that the work is not completed.

The Engineer shall withhold the disincentives as they accrue from the amount of monies due on work performed in the contract.

Upon apparent completion of all work required to be completed by this intermediate date, a final inspection will be held in accordance with Article 105-17 and upon acceptance, the Department will assume responsibility for maintenance of all work except *Planting, Reforestation and/or Permanent Vegetation Establishment*. The Contractor will be responsible for and shall make corrections of all damages to the completed roadway caused by planting operations, whether occurring prior to or after placing traffic through the project.

INTERMEDIATE CONTRACT TIME NUMBER 2 AND LIQUIDATED DAMAGES:

(2-20-07)

108

SP1 G14 A

The Contractor shall complete the required work of installing, maintaining, and removing the traffic control devices for lane closures and restoring traffic to the existing traffic pattern. The Contractor shall not close or narrow a lane of traffic on **Idols Rd (SR 3000), Hampton Rd (SR 2999) and US 158** during the following time restrictions:

DAY AND TIME RESTRICTIONS

Sunday thru Saturday

6:00 AM to 9:00 AM

And

4:00 PM to 7:00 PM

In addition, the Contractor shall not close or narrow a lane of traffic on **Idols Rd (SR 3000), Hampton Rd (SR 2999) and US 158**, detain and/or alter the traffic flow on or during holidays, holiday weekends, special events, or any other time when traffic is unusually heavy, including the following schedules:

HOLIDAY AND HOLIDAY WEEKEND LANE CLOSURE RESTRICTIONS

1. For **unexpected occurrence** that creates unusually high traffic volumes, as directed by the Engineer.

2. For **New Year's Day**, between the hours of **6:00 AM** December 31st and **7:00 PM** January 2nd. If New Year's Day is on a Friday, Saturday, Sunday or Monday, then until **7:00 PM** the following Tuesday.
3. For **Easter**, between the hours of **6:00 AM** Thursday and **7:00 PM** Monday.
4. For **Memorial Day**, between the hours of **6:00 AM** Friday and **7:00 PM** Tuesday.
5. For **Independence Day**, between the hours of **6:00 AM** the day before Independence Day and **7:00 PM** the day after Independence Day.

If **Independence Day** is on a Friday, Saturday, Sunday or Monday, then between the hours of **6:00 AM** the Thursday before Independence Day and **7:00 PM** the Tuesday after Independence Day.
6. For **Labor Day**, between the hours of **6:00 AM** Friday and **7:00 PM** Tuesday.
7. For **Thanksgiving Day**, between the hours of **6:00 AM** Tuesday and **7:00 PM** Monday.
8. For **Christmas**, between the hours of **6:00 AM** the Friday before the week of Christmas Day and **7:00 PM** the following Tuesday after the week of Christmas Day.

Holidays and holiday weekends shall include New Year's, Easter, Memorial Day, Independence Day, Labor Day, Thanksgiving, and Christmas. The Contractor shall schedule his work so that lane closures will not be required during these periods, unless otherwise directed by the Engineer.

The time of availability for this intermediate contract work shall be the time the Contractor begins to install all traffic control devices for lane closures according to the time restrictions listed herein.

The completion time for this intermediate contract work shall be the time the Contractor is required to complete the removal of all traffic control devices for lane closures according to the time restrictions stated above and place traffic in the existing traffic pattern.

The liquidated damages are **One Thousand Dollars (\$ 1,000.00)** per hour.

PERMANENT VEGETATION ESTABLISHMENT:

(2-16-12) (Rev. 10-15-13)

104

SP1 G16

Establish a permanent stand of the vegetation mixture shown in the contract. During the period between initial vegetation planting and final project acceptance, perform all work necessary to establish permanent vegetation on all erodible areas within the project limits, as well as, in borrow and waste pits. This work shall include erosion control device maintenance and installation, repair seeding and mulching, supplemental seeding and mulching, mowing, and fertilizer topdressing, as directed. All work shall be performed in accordance with the

applicable section of the *2012 Standard Specifications*. All work required for initial vegetation planting shall be performed as a part of the work necessary for the completion and acceptance of the Intermediate Contract Time (ICT). Between the time of ICT and Final Project acceptance, or otherwise referred to as the vegetation establishment period, the Department will be responsible for preparing the required National Pollutant Discharge Elimination System (NPDES) inspection records.

Once the Engineer has determined that the permanent vegetation establishment requirement has been achieved at an 80% vegetation density (the amount of established vegetation per given area to stabilize the soil) and no erodible areas exist within the project limits, the Contractor will be notified to remove the remaining erosion control devices that are no longer needed. The Contractor will be responsible for, and shall correct any areas disturbed by operations performed in permanent vegetation establishment and the removal of temporary erosion control measures, whether occurring prior to or after placing traffic on the project.

Payment for *Response for Erosion Control, Seeding and Mulching, Repair Seeding, Supplemental Seeding, Mowing, Fertilizer Topdressing, Silt Excavation, and Stone for Erosion Control* will be made at contract unit prices for the affected items. Work required that is not represented by contract line items will be paid in accordance with Articles 104-7 or 104-3 of the *2012 Standard Specifications*. No additional compensation will be made for maintenance and removal of temporary erosion control items.

DELAY IN RIGHT OF ENTRY:

(7-1-95) (Rev. 7-15-14)

108

SP1 G22(Rev)

The Contractor will not be allowed right of entry to the following parcel(s) prior to the listed date(s) unless otherwise permitted by the Engineer.

<u>Parcel No.</u>	<u>Property Owner</u>	<u>Date</u>
3	Eva Katrina Roberson	06/01/16
22Z	Bingham Partners	05/07/16
33	Duke Energy	05/07/16
5Z	Pauline Pratt	04/18/16
6Z	Betty Phillips	04/18/16
7Z	James Lindsey	04/18/16
8Z	Larry Miller	04/18/16
11Z	Triumph Actuation Systems	04/18/16
32Z	Atlantis Foods	04/18/16
29Z	Carl Page Armstrong	06/01/16
26Z	Joseph & Mary Ann Goodman	06/01/16
27Z	Charles & Rhonda Kirkman	06/01/16

MAJOR CONTRACT ITEMS:

(2-19-02)

104

SP1 G28

The following listed items are the major contract items for this contract (see Article 104-5 of the 2012 Standard Specifications):

Line #	Description
9	Borrow Excavation
41	Aggregate Base Course
208	Reinforced Concrete Deck Slab
215	54" Prestressed Concrete Girders

SPECIALTY ITEMS:

(7-1-95)(Rev. 1-17-12)

108-6

SP1 G37

Items listed below will be the specialty items for this contract (see Article 108-6 of the 2012 Standard Specifications).

Line #	Description
78-82	Guardrail
220	Fencing
89-93	Signing
107-113	Long-Life Pavement Markings
118	Permanent Pavement Markers
119-139	Utility Construction
140-169, 172-176	Erosion Control
170-171	Reforestation
177-195	Signals/ITS System
201-206	Drilled Piers

FUEL PRICE ADJUSTMENT:

(11-15-05) (Rev. 2-18-14)

109-8

SP1 G43

Revise the 2012 Standard Specifications as follows:

Page 1-83, Article 109-8, Fuel Price Adjustments, add the following:

The base index price for DIESEL #2 FUEL is \$ **1.1131** per gallon. Where any of the following are included as pay items in the contract, they will be eligible for fuel price adjustment.

The pay items and the fuel factor used in calculating adjustments to be made will be as follows:

Description	Units	Fuel Usage Factor Diesel
Unclassified Excavation	Gal/CY	0.29
Borrow Excavation	Gal/CY	0.29
Class IV Subgrade Stabilization	Gal/Ton	0.55
Aggregate Base Course	Gal/Ton	0.55

Sub-Ballast	Gal/Ton	0.55
Asphalt Concrete Base Course, Type ____	Gal/Ton	2.90
Asphalt Concrete Intermediate Course, Type ____	Gal/Ton	2.90
Asphalt Concrete Surface Course, Type ____	Gal/Ton	2.90
Open-Graded Asphalt Friction Course	Gal/Ton	2.90
Permeable Asphalt Drainage Course, Type ____	Gal/Ton	2.90
Sand Asphalt Surface Course, Type ____	Gal/Ton	2.90
Aggregate for Cement Treated Base Course	Gal/Ton	0.55
Portland Cement for Cement Treated Base Course	Gal/Ton	0.55
__" Portland Cement Concrete Pavement	Gal/SY	0.245
Concrete Shoulders Adjacent to __" Pavement	Gal/SY	0.245

SCHEDULE OF ESTIMATED COMPLETION PROGRESS:

(7-15-08) (Rev. 5-19-15)

108-2

SP1 G58

The Contractor's attention is directed to the Standard Special Provision entitled *Availability of Funds Termination of Contracts* included elsewhere in this proposal. The Department of Transportation's schedule of estimated completion progress for this project as required by that Standard Special Provision is as follows:

2016	(7/01/15 - 6/30/16)	8 % of Total Amount Bid
2017	(7/01/16 - 6/30/17)	79 % of Total Amount Bid
2018	(7/01/17 - 6/30/18)	13 % of Total Amount Bid

The Contractor shall also furnish his own progress schedule in accordance with Article 108-2 of the *2012 Standard Specifications*. Any acceleration of the progress as shown by the Contractor's progress schedule over the progress as shown above shall be subject to the approval of the Engineer.

MINORITY BUSINESS ENTERPRISE AND WOMEN BUSINESS ENTERPRISE:

(10-16-07)(Rev. 4-19-16)

102-15(J)

SP1 G66

Description

The purpose of this Special Provision is to carry out the North Carolina Department of Transportation's policy of ensuring nondiscrimination in the award and administration of contracts financed in whole or in part with State funds.

Definitions

Additional MBE/WBE Subcontractors - Any MBE/WBE submitted at the time of bid that will not be used to meet either the MBE or WBE goal. No submittal of a Letter of Intent is required, unless the additional participation is used for banking purposes.

Committed MBE/WBE Subcontractor - Any MBE/WBE submitted at the time of bid that is being used to meet either the MBE or WBE goal by submission of a Letter of Intent. Or any MBE or WBE used as a replacement for a previously committed MBE or WBE firm.

Contract Goals Requirement - The approved MBE and WBE participation at time of award, but not greater than the advertised contract goals for each.

Goal Confirmation Letter - Written documentation from the Department to the bidder confirming the Contractor's approved, committed MBE and WBE participation along with a listing of the committed MBE and WBE firms.

Manufacturer - A firm that operates or maintains a factory or establishment that produces on the premises, the materials or supplies obtained by the Contractor.

MBE Goal - A portion of the total contract, expressed as a percentage, that is to be performed by committed MBE subcontractor(s).

Minority Business Enterprise (MBE) - A firm certified as a Disadvantaged Minority-Owned Business Enterprise through the North Carolina Unified Certification Program.

Regular Dealer - A firm that owns, operates, or maintains a store, warehouse, or other establishment in which the materials or supplies required for the performance of the contract are bought, kept in stock, and regularly sold to the public in the usual course of business. A regular dealer engages in, as its principal business and in its own name, the purchase and sale or lease of the products in question. A regular dealer in such bulk items as steel, cement, gravel, stone, and petroleum products need not keep such products in stock, if it owns and operates distribution equipment for the products. Brokers and packagers are not regarded as manufacturers or regular dealers within the meaning of this section.

North Carolina Unified Certification Program (NCUCP) - A program that provides comprehensive services and information to applicants for MBE/WBE certification. The MBE/WBE program follows the same regulations as the federal Disadvantaged Business Enterprise (DBE) program in accordance with 49 CFR Part 26.

United States Department of Transportation (USDOT) - Federal agency responsible for issuing regulations (49 CFR Part 26) and official guidance for the DBE program.

WBE Goal - A portion of the total contract, expressed as a percentage, that is to be performed by committed WBE subcontractor(s).

Women Business Enterprise (WBE) - A firm certified as a Disadvantaged Women-Owned Business Enterprise through the North Carolina Unified Certification Program.

Forms and Websites Referenced in this Provision

Payment Tracking System - On-line system in which the Contractor enters the payments made to MBE and WBE subcontractors who have performed work on the project.
<https://apps.dot.state.nc.us/Vendor/PaymentTracking/>

DBE-IS Subcontractor Payment Information - Form for reporting the payments made to all MBE/WBE firms working on the project. This form is for paper bid projects only.
<http://www.ncdot.org/doh/forms/files/DBE-IS.xls>

RF-1 MBE/WBE Replacement Request Form - Form for replacing a committed MBE or WBE.
<http://connect.ncdot.gov/projects/construction/Construction%20Forms/DBE%20MBE%20WBE%20Replacement%20Request%20Form.pdf>

SAF Subcontract Approval Form - Form required for approval to sublet the contract.
<http://connect.ncdot.gov/projects/construction/Construction%20Forms/Subcontract%20Approval%20Form%20Rev.%202012.zip>

JC-1 Joint Check Notification Form - Form and procedures for joint check notification. The form acts as a written joint check agreement among the parties providing full and prompt disclosure of the expected use of joint checks.
<http://connect.ncdot.gov/projects/construction/Construction%20Forms/Joint%20Check%20Notification%20Form.pdf>

Letter of Intent - Form signed by the Contractor and the MBE/WBE subcontractor, manufacturer or regular dealer that affirms that a portion of said contract is going to be performed by the signed MBE/WBE for the amount listed at the time of bid.
<http://connect.ncdot.gov/letting/LetCentral/Letter%20of%20Intent%20to%20Perform%20as%20a%20Subcontractor.pdf>

Listing of MBE and WBE Subcontractors Form - Form for entering MBE/WBE subcontractors on a project that will meet this MBE and WBE goals. This form is for paper bids only.
[http://connect.ncdot.gov/municipalities/Bid%20Proposals%20for%20LGA%20Content/09%20MBE-WBE%20Subcontractors%20\(State\).docx](http://connect.ncdot.gov/municipalities/Bid%20Proposals%20for%20LGA%20Content/09%20MBE-WBE%20Subcontractors%20(State).docx)

Subcontractor Quote Comparison Sheet - Spreadsheet for showing all subcontractor quotes in the work areas where MBEs and WBEs quoted on the project. This sheet is submitted with good faith effort packages.
<http://connect.ncdot.gov/business/SmallBusiness/Documents/DBE%20Subcontractor%20Quote%20Comparison%20Example.xls>

MBE and WBE Goal

The following goals for participation by Minority Business Enterprises and Women Business Enterprises are established for this contract:

(A) Minority Business Enterprises **4.0 %**

- (1) *If the MBE goal is more than zero*, the Contractor shall exercise all necessary and reasonable steps to ensure that MBEs participate in at least the percent of the contract as set forth above as the MBE goal.

- (2) *If the MBE goal is zero*, the Contractor shall make an effort to recruit and use MBEs during the performance of the contract. Any MBE participation obtained shall be reported to the Department.
- (B) Women Business Enterprises **6.0 %**
- (1) *If the WBE goal is more than zero*, the Contractor shall exercise all necessary and reasonable steps to ensure that WBEs participate in at least the percent of the contract as set forth above as the WBE goal.
 - (2) *If the WBE goal is zero*, the Contractor shall make an effort to recruit and use WBEs during the performance of the contract. Any WBE participation obtained shall be reported to the Department.

Directory of Transportation Firms (Directory)

Real-time information is available about firms doing business with the Department and firms that are certified through NCUCP in the Directory of Transportation Firms. Only firms identified in the Directory as MBE and WBE certified shall be used to meet the MBE and WBE goals respectively. The Directory can be found at the following link. <https://partner.ncdot.gov/VendorDirectory/default.html>

The listing of an individual firm in the directory shall not be construed as an endorsement of the firm's capability to perform certain work.

Listing of MBE/WBE Subcontractors

At the time of bid, bidders shall submit all MBE and WBE participation that they anticipate to use during the life of the contract. Only those identified to meet the MBE goal and the WBE goal will be considered committed, even though the listing shall include both committed MBE/WBE subcontractors and additional MBE/WBE subcontractors. Any additional MBE/WBE subcontractor participation above the goal for which letters of intent are received will follow the banking guidelines found elsewhere in this provision. All other additional MBE/WBE subcontractor participation submitted at the time of bid will be used toward the Department's overall race-neutral goals. Only those firms with current MBE and WBE certification at the time of bid opening will be acceptable for listing in the bidder's submittal of MBE and WBE participation. The Contractor shall indicate the following required information:

(A) Electronic Bids

Bidders shall submit a listing of MBE and WBE participation in the appropriate section of Expedite, the bidding software of Bid Express[®].

- (1) Submit the names and addresses of MBE and WBE firms identified to participate in the contract. If the bidder uses the updated listing of MBE and WBE firms

shown in Expedite, the bidder may use the dropdown menu to access the name and address of the firms.

- (2) Submit the contract line numbers of work to be performed by each MBE and WBE firm. When no figures or firms are entered, the bidder will be considered to have no MBE or WBE participation.
- (3) The bidder shall be responsible for ensuring that the MBE and WBE are certified at the time of bid by checking the Directory of Transportation Firms. If the firm is not certified at the time of the bid-letting, that MBE's or WBE's participation will not count towards achieving either the MBE or WBE goal.

(B) Paper Bids

- (1) *If either the MBE or WBE goal is more than zero,*
 - (a) Bidders, at the time the bid proposal is submitted, shall submit a listing of MBE/WBE participation, including the names and addresses on *Listing of MBE and WBE Subcontractors* contained elsewhere in the contract documents in order for the bid to be considered responsive. Bidders shall indicate the total dollar value of the MBE and WBE participation for the contract.
 - (b) If bidders have no MBE or WBE participation, they shall indicate this on the *Listing of MBE and WBE Subcontractors* by entering the word "None" or the number "0." This form shall be completed in its entirety. **Blank forms will not be deemed to represent zero participation.** Bids submitted that do not have MBE and WBE participation indicated on the appropriate form will not be read publicly during the opening of bids. The Department will not consider these bids for award and the proposal will be rejected.
 - (c) The bidder shall be responsible for ensuring that the MBE/WBE is certified at the time of bid by checking the Directory of Transportation Firms. If the firm is not certified at the time of the bid-letting, that MBE's or WBE's participation will not count towards achieving the corresponding goal.
- (2) *If either the MBE or WBE goal is zero,* entries on the *Listing of MBE and WBE Subcontractors* are not required for the zero goal, however any MBE or WBE participation that is achieved during the project shall be reported in accordance with requirements contained elsewhere in the special provision.

MBE or WBE Prime Contractor

When a certified MBE or WBE firm bids on a contract that contains MBE and WBE goals, the firm is responsible for meeting the goals or making good faith efforts to meet the goals, just like any other bidder. In most cases, a MBE or WBE bidder on a contract will meet one of the goals by virtue of the work it performs on the contract with its own forces. However, all the work that is performed by the MBE or WBE bidder and any other similarly certified subcontractors will count toward the goal. The MBE or WBE bidder shall list itself along with any MBE or WBE subcontractors, if any, in order to receive credit toward the goals.

For example, on a proposed contract, the WBE goal is 10%, and the MBE goal is 8%. A WBE bidder puts in a bid where they will perform 40% of the contract work and have a WBE subcontractor which will perform another 5% of the work. Together the two WBE firms submit on the *Listing of MBE and WBE Subcontractors* a value of 45% of the contract which fulfills the WBE goal. The 8% MBE goal shall be obtained through MBE participation with MBE certified subcontractors or documented through a good faith effort. It should be noted that you cannot combine the two goals to meet an overall value. The two goals shall remain separate.

MBE/WBE prime contractors shall also follow Sections A and B listed under *Listing of MBE and WBE Subcontractor* just as a non-MBE/WBE bidder would.

Written Documentation – Letter of Intent

The bidder shall submit written documentation for each MBE/WBE that will be used to meet the MBE and WBE goals of the contract, indicating the bidder's commitment to use the MBE/WBE in the contract. This documentation shall be submitted on the Department's form titled *Letter of Intent*.

The documentation shall be received in the office of the State Contractor Utilization Engineer or at DBE@ncdot.gov no later than 12:00 noon of the sixth calendar day following opening of bids, unless the sixth day falls on an official state holiday. In that situation, it is due in the office of the State Contractor Utilization Engineer no later than 12:00 noon on the next official state business day.

If the bidder fails to submit the Letter of Intent from each committed MBE and WBE to be used toward the MBE and WBE goals, or if the form is incomplete (i.e. both signatures are not present), the MBE/WBE participation will not count toward meeting the MBE/WBE goal. If the lack of this participation drops the commitment below either the MBE or WBE goal, the Contractor shall submit evidence of good faith efforts for the goal not met, completed in its entirety, to the State Contractor Utilization Engineer or DBE@ncdot.gov no later than 12:00 noon on the eighth calendar day following opening of bids, unless the eighth day falls on an official state holiday. In that situation, it is due in the office of the State Contractor Utilization Engineer no later than 12:00 noon on the next official state business day.

Submission of Good Faith Effort

If the bidder fails to meet or exceed either the MBE or the WBE goal, the apparent lowest responsive bidder shall submit to the Department documentation of adequate good faith efforts made to reach that specific goal(s).

A hard copy and an electronic copy of this information shall be received in the office of the State Contractor Utilization Engineer or at DBE@ncdot.gov no later than 12:00 noon of the sixth calendar day following opening of bids unless the sixth day falls on an official state holiday. In that situation, it would be due in the office of the State Contractor Utilization Engineer the next official state business day. If the contractor cannot send the information electronically, then one complete set and 9 copies of this information shall be received under the same time constraints above.

Note: Where the information submitted includes repetitious solicitation letters, it will be acceptable to submit a representative letter along with a distribution list of the firms that were solicited. Documentation of MBE/WBE quotations shall be a part of the good faith effort submittal. This documentation may include written subcontractor quotations, telephone log notations of verbal quotations, or other types of quotation documentation.

Consideration of Good Faith Effort for Projects with MBE/WBE Goals More Than Zero

Adequate good faith efforts mean that the bidder took all necessary and reasonable steps to achieve the goal which, by their scope, intensity, and appropriateness, could reasonably be expected to obtain sufficient MBE/WBE participation. Adequate good faith efforts also mean that the bidder actively and aggressively sought MBE/WBE participation. Mere *pro forma* efforts are not considered good faith efforts.

The Department will consider the quality, quantity, and intensity of the different kinds of efforts a bidder has made. Listed below are examples of the types of actions a bidder will take in making a good faith effort to meet the goals and are not intended to be exclusive or exhaustive, nor is it intended to be a mandatory checklist.

- (A) Soliciting through all reasonable and available means (e.g. attendance at pre-bid meetings, advertising, written notices, use of verifiable electronic means through the use of the NCDOT Directory of Transportation Firms) the interest of all certified MBEs/WBEs who have the capability to perform the work of the contract. The bidder must solicit this interest within at least 10 days prior to bid opening to allow the MBEs/WBEs to respond to the solicitation. Solicitation shall provide the opportunity to MBEs/WBEs within the Division and surrounding Divisions where the project is located. The bidder must determine with certainty if the MBEs/WBEs are interested by taking appropriate steps to follow up initial solicitations.

- (B) Selecting portions of the work to be performed by MBEs/WBEs in order to increase the likelihood that the MBE and WBE goals will be achieved.
 - (1) Where appropriate, break out contract work items into economically feasible units to facilitate MBE/WBE participation, even when the prime contractor might otherwise prefer to perform these work items with its own forces.
 - (2) Negotiate with subcontractors to assume part of the responsibility to meet the contract MBE/WBE goals when the work to be sublet includes potential for MBE/WBE participation (2nd and 3rd tier subcontractors).
- (C) Providing interested MBEs/WBEs with adequate information about the plans, specifications, and requirements of the contract in a timely manner to assist them in responding to a solicitation.
- (D)
 - (1) Negotiating in good faith with interested MBEs/WBEs. It is the bidder's responsibility to make a portion of the work available to MBE/WBE subcontractors and suppliers and to select those portions of the work or material needs consistent with the available MBE/WBE subcontractors and suppliers, so as to facilitate MBE/WBE participation. Evidence of such negotiation includes the names, addresses, and telephone numbers of MBEs/WBEs that were considered; a description of the information provided regarding the plans and specifications for the work selected for subcontracting; and evidence as to why additional agreements could not be reached for MBEs/WBEs to perform the work.
 - (2) A bidder using good business judgment would consider a number of factors in negotiating with subcontractors, including MBE/WBE subcontractors, and would take a firm's price and capabilities as well as contract goals into consideration. However, the fact that there may be some additional costs involved in finding and using MBEs/WBEs is not in itself sufficient reason for a bidder's failure to meet the contract MBE or WBE goals, as long as such costs are reasonable. Also, the ability or desire of a prime contractor to perform the work of a contract with its own organization does not relieve the bidder of the responsibility to make good faith efforts. Bidding contractors are not, however, required to accept higher quotes from MBEs/WBEs if the price difference is excessive or unreasonable.
- (E) Not rejecting MBEs/WBEs as being unqualified without sound reasons based on a thorough investigation of their capabilities. The bidder's standing within its industry, membership in specific groups, organizations, or associates and political or social affiliations (for example, union vs. non-union employee status) are not legitimate causes for the rejection or non-solicitation of bids in the bidder's efforts to meet the project goal.
- (F) Making efforts to assist interested MBEs/WBEs in obtaining bonding, lines of credit, or insurance as required by the recipient or bidder.

- (G) Making efforts to assist interested MBEs/WBEs in obtaining necessary equipment, supplies, materials, or related assistance or services.
- (H) Effectively using the services of available minority/women community organizations; minority/women contractors' groups; Federal, State, and local minority/women business assistance offices; and other organizations as allowed on a case-by-case basis to provide assistance in the recruitment and placement of MBEs/WBEs. Contact within 7 days from the bid opening the Business Development Manager in the Business Opportunity and Work Force Development Unit to give notification of the bidder's inability to get MBE or WBE quotes.
- (I) Any other evidence that the bidder submits which shows that the bidder has made reasonable good faith efforts to meet the MBE and WBE goal.

In addition, the Department may take into account the following:

- (1) Whether the bidder's documentation reflects a clear and realistic plan for achieving the MBE and WBE goals.
- (2) The bidders' past performance in meeting the MBE and WBE goals.
- (3) The performance of other bidders in meeting the MBE and WBE goals. For example, when the apparent successful bidder fails to meet the goals, but others meet it, you may reasonably raise the question of whether, with additional reasonable efforts the apparent successful bidder could have met the goals. If the apparent successful bidder fails to meet the MBE and WBE goals, but meets or exceeds the average MBE and WBE participation obtained by other bidders, the Department may view this, in conjunction with other factors, as evidence of the apparent successful bidder having made a good faith effort.

If the Department does not award the contract to the apparent lowest responsive bidder, the Department reserves the right to award the contract to the next lowest responsive bidder that can satisfy to the Department that the MBE and WBE goals can be met or that an adequate good faith effort has been made to meet the MBE and WBE goals.

Non-Good Faith Appeal

The State Contractual Services Engineer will notify the contractor verbally and in writing of non-good faith. A contractor may appeal a determination of non-good faith made by the Goal Compliance Committee. If a contractor wishes to appeal the determination made by the Committee, they shall provide written notification to the State Contractual Services Engineer or at DBE@ncdot.gov. The appeal shall be made within 2 business days of notification of the determination of non-good faith.

Counting MBE/WBE Participation Toward Meeting MBE/WBE Goals**(A) Participation**

The total dollar value of the participation by a committed MBE/WBE will be counted toward the contract goal requirements. The total dollar value of participation by a committed MBE/WBE will be based upon the value of work actually performed by the MBE/WBE and the actual payments to MBE/WBE firms by the Contractor.

(B) Joint Checks

Prior notification of joint check use shall be required when counting MBE/WBE participation for services or purchases that involves the use of a joint check. Notification shall be through submission of Form JC-1 (*Joint Check Notification Form*) and the use of joint checks shall be in accordance with the Department's Joint Check Procedures.

(C) Subcontracts (Non-Trucking)

A MBE/WBE may enter into subcontracts. Work that a MBE subcontracts to another MBE firm may be counted toward the MBE contract goal requirement. The same holds for work that a WBE subcontracts to another WBE firm. Work that a MBE subcontracts to a non-MBE firm does not count toward the MBE contract goal requirement. Again, the same holds true for the work that a WBE subcontracts to a non-WBE firm. If a MBE or WBE contractor or subcontractor subcontracts a significantly greater portion of the work of the contract than would be expected on the basis of standard industry practices, it shall be presumed that the MBE or WBE is not performing a commercially useful function. The MBE/WBE may present evidence to rebut this presumption to the Department. The Department's decision on the rebuttal of this presumption may be subject to review by the Office of Inspector General, NCDOT.

(D) Joint Venture

When a MBE or WBE performs as a participant in a joint venture, the Contractor may count toward its contract goal requirement a portion of the total value of participation with the MBE or WBE in the joint venture, that portion of the total dollar value being a distinct clearly defined portion of work that the MBE or WBE performs with its forces.

(E) Suppliers

A contractor may count toward its MBE or WBE requirement 60 percent of its expenditures for materials and supplies required to complete the contract and obtained from a MBE or WBE regular dealer and 100 percent of such expenditures from a MBE or WBE manufacturer.

(F) **Manufacturers and Regular Dealers**

A contractor may count toward its MBE or WBE requirement the following expenditures to MBE/WBE firms that are not manufacturers or regular dealers:

- (1) The fees or commissions charged by a MBE/WBE firm for providing a *bona fide* service, such as professional, technical, consultant, or managerial services, or for providing bonds or insurance specifically required for the performance of a DOT-assisted contract, provided the fees or commissions are determined to be reasonable and not excessive as compared with fees and commissions customarily allowed for similar services.
- (2) With respect to materials or supplies purchased from a MBE/WBE, which is neither a manufacturer nor a regular dealer, count the entire amount of fees or commissions charged for assistance in the procurement of the materials and supplies, or fees or transportation charges for the delivery of materials or supplies required on a job site (but not the cost of the materials and supplies themselves), provided the fees are determined to be reasonable and not excessive as compared with fees customarily allowed for similar services.

Commercially Useful Function

(A) **MBE/WBE Utilization**

The Contractor may count toward its contract goal requirement only expenditures to MBEs and WBEs that perform a commercially useful function in the work of a contract. A MBE/WBE performs a commercially useful function when it is responsible for execution of the work of the contract and is carrying out its responsibilities by actually performing, managing, and supervising the work involved. To perform a commercially useful function, the MBE/WBE shall also be responsible with respect to materials and supplies used on the contract, for negotiating price, determining quality and quantity, ordering the material and installing (where applicable) and paying for the material itself. To determine whether a MBE/WBE is performing a commercially useful function, the Department will evaluate the amount of work subcontracted, industry practices, whether the amount the firm is to be paid under the contract is commensurate with the work it is actually performing and the MBE/WBE credit claimed for its performance of the work, and any other relevant factors.

(B) **MBE/WBE Utilization in Trucking**

The following factors will be used to determine if a MBE or WBE trucking firm is performing a commercially useful function:

- (1) The MBE/WBE shall be responsible for the management and supervision of the entire trucking operation for which it is responsible on a particular contract, and

there shall not be a contrived arrangement for the purpose of meeting the MBE or WBE goal.

- (2) The MBE/WBE shall itself own and operate at least one fully licensed, insured, and operational truck used on the contract.
- (3) The MBE/WBE receives credit for the total value of the transportation services it provides on the contract using trucks it owns, insures, and operates using drivers it employs.
- (4) The MBE may subcontract the work to another MBE firm, including an owner-operator who is certified as a MBE. The same holds true that a WBE may subcontract the work to another WBE firm, including an owner-operator who is certified as a WBE. When this occurs, the MBE or WBE who subcontracts work receives credit for the total value of the transportation services the subcontracted MBE or WBE provides on the contract. It should be noted that every effort shall be made by MBE and WBE contractors to subcontract to the same certification (i.e., MBEs to MBEs and WBEs to WBEs), in order to fulfill the goal requirement. This, however, may not always be possible due to the limitation of firms in the area. If the MBE or WBE firm shows a good faith effort has been made to reach out to similarly certified transportation service providers and there is no interest or availability, and they can get assistance from other certified providers, the Engineer will not hold the prime liable for meeting the goal.
- (5) The MBE/WBE may also subcontract the work to a non-MBE/WBE firm, including from an owner-operator. The MBE/WBE who subcontracts the work to a non-MBE/WBE is entitled to credit for the total value of transportation services provided by the non-MBE/WBE subcontractor not to exceed the value of transportation services provided by MBE/WBE-owned trucks on the contract. Additional participation by non-MBE/WBE subcontractors receives credit only for the fee or commission it receives as a result of the subcontract arrangement. The value of services performed under subcontract agreements between the MBE/WBE and the Contractor will not count towards the MBE/WBE contract requirement.
- (6) A MBE/WBE may lease truck(s) from an established equipment leasing business open to the general public. The lease must indicate that the MBE/WBE has exclusive use of and control over the truck. This requirement does not preclude the leased truck from working for others during the term of the lease with the consent of the MBE/WBE, so long as the lease gives the MBE/WBE absolute priority for use of the leased truck. This type of lease may count toward the MBE/WBE's credit as long as the driver is under the MBE/WBE's payroll.

- (7) Subcontracted/leased trucks shall display clearly on the dashboard the name of the MBE/WBE that they are subcontracted/leased to and their own company name if it is not identified on the truck itself. Magnetic door signs are not permitted.

Banking MBE/WBE Credit

If the bid of the lowest responsive bidder exceeds \$500,000 and if the committed MBE/WBE participation submitted by Letter of Intent exceeds the algebraic sum of the MBE or WBE goal by \$1,000 or more, the excess will be placed on deposit by the Department for future use by the bidder. Separate accounts will be maintained for MBE and WBE participation and these may accumulate for a period not to exceed 24 months.

When the apparent lowest responsive bidder fails to submit sufficient participation by MBE firms to meet the contract goal, as part of the good faith effort, the Department will consider allowing the bidder to withdraw funds to meet the MBE goal as long as there are adequate funds available from the bidder's MBE bank account.

When the apparent lowest responsive bidder fails to submit sufficient participation by WBE firms to meet the contract goal, as part of the good faith effort, the Department will consider allowing the bidder to withdraw funds to meet the WBE goal as long as there are adequate funds available from the bidder's WBE bank account.

MBE/WBE Replacement

When a Contractor has relied on a commitment to a MBE or WBE firm (or an approved substitute MBE or WBE firm) to meet all or part of a contract goal requirement, the contractor shall not terminate the MBE/WBE for convenience. This includes, but is not limited to, instances in which the Contractor seeks to perform the work of the terminated subcontractor with another MBE/WBE subcontractor, a non-MBE/WBE subcontractor, or with the Contractor's own forces or those of an affiliate. A MBE/WBE may only be terminated after receiving the Engineer's written approval based upon a finding of good cause for the termination. The prime contractor must give the MBE/WBE firm five (5) calendar days to respond to the prime contractor's notice of termination and advise the prime contractor and the Department of the reasons, if any, why the firm objects to the proposed termination of its subcontract and why the Department should not approve the action.

All requests for replacement of a committed MBE/WBE firm shall be submitted to the Engineer for approval on Form RF-1 (*Replacement Request*). If the Contractor fails to follow this procedure, the Contractor may be disqualified from further bidding for a period of up to 6 months.

The Contractor shall comply with the following for replacement of a committed MBE/WBE:

(A) Performance Related Replacement

When a committed MBE is terminated for good cause as stated above, an additional MBE that was submitted at the time of bid may be used to fulfill the MBE commitment.

The same holds true if a committed WBE is terminated for good cause, an additional WBE that was submitted at the time of bid may be used to fulfill the WBE goal. A good faith effort will only be required for removing a committed MBE/WBE if there were no additional MBEs/WBEs submitted at the time of bid to cover the same amount of work as the MBE/WBE that was terminated.

If a replacement MBE/WBE is not found that can perform at least the same amount of work as the terminated MBE/WBE, the Contractor shall submit a good faith effort documenting the steps taken. Such documentation shall include, but not be limited to, the following:

- (1) Copies of written notification to MBEs/WBEs that their interest is solicited in contracting the work defaulted by the previous MBE/WBE or in subcontracting other items of work in the contract.
 - (2) Efforts to negotiate with MBEs/WBEs for specific subbids including, at a minimum:
 - (a) The names, addresses, and telephone numbers of MBEs/WBEs who were contacted.
 - (b) A description of the information provided to MBEs/WBEs regarding the plans and specifications for portions of the work to be performed.
 - (3) A list of reasons why MBE/WBE quotes were not accepted.
 - (4) Efforts made to assist the MBEs/WBEs contacted, if needed, in obtaining bonding or insurance required by the Contractor.
- (B) Decertification Replacement
- (1) When a committed MBE/WBE is decertified by the Department after the SAF (*Subcontract Approval Form*) has been received by the Department, the Department will not require the Contractor to solicit replacement MBE/WBE participation equal to the remaining work to be performed by the decertified firm. The participation equal to the remaining work performed by the decertified firm will count toward the contract goal requirement.
 - (2) When a committed MBE/WBE is decertified prior to the Department receiving the SAF (*Subcontract Approval Form*) for the named MBE/WBE firm, the Contractor shall take all necessary and reasonable steps to replace the MBE/WBE subcontractor with another similarly certified MBE/WBE subcontractor to perform at least the same amount of work to meet the MBE/WBE goal requirement. If a MBE/WBE firm is not found to do the same amount of work, a good faith effort must be submitted to NCDOT (see A herein for required documentation).

Changes in the Work

When the Engineer makes changes that result in the reduction or elimination of work to be performed by a committed MBE/WBE, the Contractor will not be required to seek additional participation. When the Engineer makes changes that result in additional work to be performed by a MBE/WBE based upon the Contractor's commitment, the MBE/WBE shall participate in additional work to the same extent as the MBE/WBE participated in the original contract work.

When the Engineer makes changes that result in extra work, which has more than a minimal impact on the contract amount, the Contractor shall seek additional participation by MBEs/WBEs unless otherwise approved by the Engineer.

When the Engineer makes changes that result in an alteration of plans or details of construction, and a portion or all of the work had been expected to be performed by a committed MBE/WBE, the Contractor shall seek participation by MBEs/WBEs unless otherwise approved by the Engineer.

When the Contractor requests changes in the work that result in the reduction or elimination of work that the Contractor committed to be performed by a MBE/WBE, the Contractor shall seek additional participation by MBEs/WBEs equal to the reduced MBE/WBE participation caused by the changes.

Reports and Documentation

A SAF (*Subcontract Approval Form*) shall be submitted for all work which is to be performed by a MBE/WBE subcontractor. The Department reserves the right to require copies of actual subcontract agreements involving MBE/WBE subcontractors.

When using transportation services to meet the contract commitment, the Contractor shall submit a proposed trucking plan in addition to the SAF. The plan shall be submitted prior to beginning construction on the project. The plan shall include the names of all trucking firms proposed for use, their certification type(s), the number of trucks owned by the firm, as well as the individual truck identification numbers, and the line item(s) being performed.

Within 30 calendar days of entering into an agreement with a MBE/WBE for materials, supplies or services, not otherwise documented by the SAF as specified above, the Contractor shall furnish the Engineer a copy of the agreement. The documentation shall also indicate the percentage (60% or 100%) of expenditures claimed for MBE/WBE credit.

Reporting Minority and Women Business Enterprise Participation

The Contractor shall provide the Engineer with an accounting of payments made to all MBE and WBE firms, including material suppliers and contractors at all levels (prime, subcontractor, or second tier subcontractor). This accounting shall be furnished to the Engineer for any given month by the end of the following month. Failure to submit this information accordingly may result in the following action:

- (A) Withholding of money due in the next partial pay estimate; or
- (B) Removal of an approved contractor from the prequalified bidders' list or the removal of other entities from the approved subcontractors list.

While each contractor (prime, subcontractor, 2nd tier subcontractor) is responsible for accurate accounting of payments to MBEs/WBEs, it shall be the prime contractor's responsibility to report all monthly and final payment information in the correct reporting manner.

Failure on the part of the Contractor to submit the required information in the time frame specified may result in the disqualification of that contractor and any affiliate companies from further bidding until the required information is submitted.

Failure on the part of any subcontractor to submit the required information in the time frame specified may result in the disqualification of that contractor and any affiliate companies from being approved for work on future DOT projects until the required information is submitted.

Contractors reporting transportation services provided by non-MBE/WBE lessees shall evaluate the value of services provided during the month of the reporting period only.

At any time, the Engineer can request written verification of subcontractor payments.

The Contractor shall report the accounting of payments through the Department's Payment Tracking System.

Failure to Meet Contract Requirements

Failure to meet contract requirements in accordance with Subarticle 102-15(J) of the *2012 Standard Specifications* may be cause to disqualify the Contractor.

CONTRACTOR'S LICENSE REQUIREMENTS:

(7-1-95)

102-14

SP1 G88

If the successful bidder does not hold the proper license to perform any plumbing, heating, air conditioning, or electrical work in this contract, he will be required to sublet such work to a contractor properly licensed in accordance with *Article 2 of Chapter 87 of the General Statutes* (licensing of heating, plumbing, and air conditioning contractors) and *Article 4 of Chapter 87 of the General Statutes* (licensing of electrical contractors).

SUBSURFACE INFORMATION:

(7-1-95)

450

SP1 G112 C

Subsurface information is available on the structure portion of this project only.

LOCATING EXISTING UNDERGROUND UTILITIES:

(3-20-12)

105

SP1 G115

Revise the *2012 Standard Specifications* as follows:

Page 1-43, Article 105-8, line 28, after the first sentence, add the following:

Identify excavation locations by means of pre-marking with white paint, flags, or stakes or provide a specific written description of the location in the locate request.

VALUE ENGINEERING PROPOSAL:

(05-19-15)

104

SP01 G116

Revise the *2012 Standard Specifications* as follows:

Page 1-36, Subarticle 104-12(B) Evaluation of Proposals, lines 42-44, replace the fourth sentence of the second paragraph with the following:

Pending execution of a formal supplemental agreement implementing an approved VEP and transferal of final plans (hard copy and electronic) sealed by an engineer licensed in the State of North Carolina incorporating an approved VEP to the Resident Engineer and the State Value Management Engineer, the Contractor shall remain obligated to perform the work in accordance with the terms of the existing contract.

Page 1-37, Subarticle 104-12(D) Preliminary Review, lines 9-12, replace the first sentence of the first paragraph with the following:

Should the Contractor desire a preliminary review of a possible VEP, before expending considerable time and expense in full development, a copy of the Preliminary VEP shall be submitted to the Resident Engineer and the State Value Management Engineer at ValueManagementUnit@ncdot.gov.

Page 1-37, Subarticle 104-12(E) Final Proposal, lines 22-23, replace the first sentence of the first paragraph with the following:

A copy of the Final VEP shall be submitted by the Contractor to the Resident Engineer and the State Value Management Engineer at ValueManagementUnit@ncdot.gov.

Page 1-38, Subarticle 104-12(F) Modifications, lines 2-8, replace the first paragraph with the following:

To facilitate the preparation of revisions to contract drawings, the Contractor may purchase reproducible copies of drawings for his use through the Department's Value Management Unit. The preparation of new design drawings by or for the Contractor shall be coordinated with the appropriate Design Branch through the State Value Management Engineer. The Contractor shall provide, at no charge to the Department, one set of reproducible drawings of the approved design needed to implement the VEP. Drawings (hard copy and electronic) which are sealed by an

engineer licensed in the State of North Carolina shall be submitted to the State Value Management Engineer no later than ten (10) business days after acceptance of a VEP unless otherwise permitted.

Page 1-38, Subarticle 104-12(F) Modifications, line 17, add the following at the end of the third paragraph:

Supplemental agreements executed for design-bid-build contracts shall reflect any realized savings in the corresponding line items. Supplemental agreements executed for design-build contracts shall add one line item deducting the full savings from the total contract price and one line item crediting the Contractor with 50% of the total VEP savings.

Page 1-38, Subarticle 104-12(F) Modifications, lines 45-47, replace the eighth paragraph with the following:

Unless and until a supplemental agreement is executed and issued by the Department and final plans (hard copy and electronic) sealed by an engineer licensed in the State of North Carolina incorporating an approved VEP have been provided to the Resident Engineer and the State Value Management Engineer, the Contractor shall remain obligated to perform the work in accordance with the terms of the existing contract.

RESOURCE CONSERVATION AND ENV. SUSTAINABLE PRACTICES:

(5-21-13) (Rev. 5-19-15)

104-13

SP1 G118

In accordance with North Carolina Executive Order 156, NCGS 130A-309.14(3), and NCGS 136-28.8, it is the objective of the Department to aid in the reduction of materials that become a part of our solid waste stream, to divert materials from landfills, to find ways to recycle and reuse materials, to consider and minimize, where economically feasible, the environmental impacts associated with agency land use and acquisition, construction, maintenance and facility management for the benefit of the Citizens of North Carolina.

To achieve the mission of reducing environmental impacts across the state, the Department is committed to supporting the efforts to initiate, develop and use products and construction methods that incorporate the use of recycled, solid waste products and environmentally sustainable practices in accordance with Article 104-13 of the *Standard Specifications*.

Report the quantities of reused or recycled materials either incorporated in the project or diverted from landfills and any practice that minimizes the environmental impact on the project annually on the Project Construction Reuse and Recycling Reporting Form. The Project Construction Reuse and Recycling Reporting Form and a location tool for local recycling facilities are available at:

<http://connect.ncdot.gov/resources/Environmental/Pages/North-Carolina-Recycling-Locations.aspx>.

Submit the Project Construction Reuse and Recycling Reporting Form by August 1 annually to valuemanagementunit@ncdot.gov. For questions regarding the form or reporting, please contact the State Value Management Engineer at 919-707-4810.

DOMESTIC STEEL:

(4-16-13)

106

SP1 G120

Revise the *2012 Standard Specifications* as follows:

Page 1-49, Subarticle 106-1(B) Domestic Steel, lines 2-7, replace the first paragraph with the following:

All steel and iron products that are permanently incorporated into this project shall be produced in the United States except minimal amounts of foreign steel and iron products may be used provided the combined material cost of the items involved does not exceed 0.1% of the total amount bid for the entire project or \$2,500, whichever is greater. If invoices showing the cost of the material are not provided, the amount of the bid item involving the foreign material will be used for calculations. This minimal amount of foreign produced steel and iron products permitted for use is not applicable to high strength fasteners. Domestically produced high strength fasteners are required.

MAINTENANCE OF THE PROJECT:

(11-20-07) (Rev. 1-17-12)

104-10

SP1 G125

Revise the *2012 Standard Specifications* as follows:

Page 1-35, Article 104-10 Maintenance of the Project, line 25, add the following after the first sentence of the first paragraph:

All guardrail/guiderail within the project limits shall be included in this maintenance.

Page 1-35, Article 104-10 Maintenance of the Project, line 30, add the following as the last sentence of the first paragraph:

The Contractor shall perform weekly inspections of guardrail and guiderail and shall report damages to the Engineer on the same day of the weekly inspection. *Where damaged guardrail or guiderail is repaired or replaced as a result of maintaining the project in accordance with this article, such repair or replacement shall be performed within 7 consecutive calendar days of such inspection report.*

Page 1-35, Article 104-10 Maintenance of the Project, lines 42-44, replace the last sentence of the last paragraph with the following:

The Contractor will not be directly compensated for any maintenance operations necessary, except for maintenance of guardrail/guiderail, as this work will be considered incidental to the work covered by the various contract items. The provisions of Article 104-7, Extra Work, and Article 104-8, Compensation and Record Keeping will apply to authorized maintenance of guardrail/guiderail. Performance of weekly inspections of guardrail/guiderail, and the damage reports required as described above, will be considered to be an incidental part of the work being paid for by the various contract items.

TWELVE MONTH GUARANTEE:

(7-15-03)

108

SPI G145

- (A) The Contractor shall guarantee materials and workmanship against latent and patent defects arising from faulty materials, faulty workmanship or negligence for a period of twelve months following the date of final acceptance of the work for maintenance and shall replace such defective materials and workmanship without cost to the Department. The Contractor will not be responsible for damage due to faulty design, normal wear and tear, for negligence on the part of the Department, and/or for use in excess of the design.
- (B) Where items of equipment or material carry a manufacturer's guarantee for any period in excess of twelve months, then the manufacturer's guarantee shall apply for that particular piece of equipment or material. The Department's first remedy shall be through the manufacturer although the Contractor is responsible for invoking the warranted repair work with the manufacturer. The Contractor's responsibility shall be limited to the term of the manufacturer's guarantee. NCDOT would be afforded the same warranty as provided by the Manufacturer.

This guarantee provision shall be invoked only for major components of work in which the Contractor would be wholly responsible for under the terms of the contract. Examples would include pavement structures, bridge components, and sign structures. This provision will not be used as a mechanism to force the Contractor to return to the project to make repairs or perform additional work that the Department would normally compensate the Contractor for. In addition, routine maintenance activities (i.e. mowing grass, debris removal, ruts in earth shoulders,) are not parts of this guarantee.

Appropriate provisions of the payment and/or performance bonds shall cover this guarantee for the project.

To ensure uniform application statewide the Division Engineer will forward details regarding the circumstances surrounding any proposed guarantee repairs to the Chief Engineer for review and approval prior to the work being performed.

OUTSOURCING OUTSIDE THE USA:

(9-21-04) (Rev. 5-16-06)

SPI G150

All work on consultant contracts, services contracts, and construction contracts shall be performed in the United States of America. No work shall be outsourced outside of the United States of America.

Outsourcing for the purpose of this provision is defined as the practice of subcontracting labor, work, services, staffing, or personnel to entities located outside of the United States.

The North Carolina Secretary of Transportation shall approve exceptions to this provision in writing.

GIFTS FROM VENDORS AND CONTRACTORS:

(12-15-09)

107-1

SP1 G152

By Executive Order 24, issued by Governor Perdue, and *N.C.G.S. § 133-32*, it is unlawful for any vendor or contractor (i.e. architect, bidder, contractor, construction manager, design professional, engineer, landlord, offeror, seller, subcontractor, supplier, or vendor), to make gifts or to give favors to any State employee of the Governor's Cabinet Agencies (i.e. Administration, Commerce, Correction, Crime Control and Public Safety, Cultural Resources, Environment and Natural Resources, Health and Human Services, Juvenile Justice and Delinquency Prevention, Revenue, Transportation, and the Office of the Governor). This prohibition covers those vendors and contractors who:

- (A) Have a contract with a governmental agency; or
- (B) Have performed under such a contract within the past year; or
- (C) Anticipate bidding on such a contract in the future.

For additional information regarding the specific requirements and exemptions, vendors and contractors are encouraged to review Executive Order 24 and *N.C.G.S. § 133-32*.

Executive Order 24 also encouraged and invited other State Agencies to implement the requirements and prohibitions of the Executive Order to their agencies. Vendors and contractors should contact other State Agencies to determine if those agencies have adopted Executive Order 24.

LIABILITY INSURANCE:

(5-20-14)

SP1 G160

Revise the *2012 Standard Specifications* as follows:

Page 1-60, Article 107-15 LIABILITY INSURANCE, line 16, add the following as the second sentence of the third paragraph:

Prior to beginning services, all contractors shall provide proof of coverage issued by a workers' compensation insurance carrier, or a certificate of compliance issued by the Department of Insurance for self-insured subcontractors, irrespective of whether having regularly in service fewer than three employees.

EROSION AND SEDIMENT CONTROL/STORMWATER CERTIFICATION:

(1-16-07) (Rev 9-18-12)

105-16, 225-2, 16

SP1 G180

General

Schedule and conduct construction activities in a manner that will minimize soil erosion and the resulting sedimentation and turbidity of surface waters. Comply with the requirements herein regardless of whether or not a National Pollution discharge Elimination System (NPDES) permit for the work is required.

Establish a chain of responsibility for operations and subcontractors' operations to ensure that the *Erosion and Sediment Control/Stormwater Pollution Prevention Plan* is implemented and maintained over the life of the contract.

- (A) *Certified Supervisor* - Provide a certified Erosion and Sediment Control/Stormwater Supervisor to manage the Contractor and subcontractor operations, insure compliance with Federal, State and Local ordinances and regulations, and manage the Quality Control Program.
- (B) *Certified Foreman* - Provide a certified, trained foreman for each construction operation that increases the potential for soil erosion or the possible sedimentation and turbidity of surface waters.
- (C) *Certified Installer* - Provide a certified installer to install or direct the installation for erosion or sediment/stormwater control practices.
- (D) *Certified Designer* - Provide a certified designer for the design of the erosion and sediment control/stormwater component of reclamation plans and, if applicable, for the design of the project erosion and sediment control/stormwater plan.

Roles and Responsibilities

- (A) *Certified Erosion and Sediment Control/Stormwater Supervisor* - The Certified Supervisor shall be Level II and responsible for ensuring the erosion and sediment control/stormwater plan is adequately implemented and maintained on the project and for conducting the quality control program. The Certified Supervisor shall be on the project within 24 hours notice from initial exposure of an erodible surface to the project's final acceptance. Perform the following duties:
 - (1) **Manage Operations** - Coordinate and schedule the work of subcontractors so that erosion and sediment control/stormwater measures are fully executed for each operation and in a timely manner over the duration of the contract.
 - (a) Oversee the work of subcontractors so that appropriate erosion and sediment control/stormwater preventive measures are conformed to at each stage of the work.
 - (b) Prepare the required National Pollutant Discharge Elimination System (NPDES) Inspection Record and submit to the Engineer.
 - (c) Attend all weekly or monthly construction meetings to discuss the findings of the NPDES inspection and other related issues.
 - (d) Implement the erosion and sediment control/stormwater site plans requested.
 - (e) Provide any needed erosion and sediment control/stormwater practices for the Contractor's temporary work not shown on the plans, such as, but not limited to work platforms, temporary construction, pumping operations, plant and storage yards, and cofferdams.

- (f) Acquire applicable permits and comply with requirements for borrow pits, dewatering, and any temporary work conducted by the Contractor in jurisdictional areas.
 - (g) Conduct all erosion and sediment control/stormwater work in a timely and workmanlike manner.
 - (h) Fully perform and install erosion and sediment control/stormwater work prior to any suspension of the work.
 - (i) Coordinate with Department, Federal, State and Local Regulatory agencies on resolution of erosion and sediment control/stormwater issues due to the Contractor's operations.
 - (j) Ensure that proper cleanup occurs from vehicle tracking on paved surfaces or any location where sediment leaves the Right-of-Way.
 - (k) Have available a set of erosion and sediment control/stormwater plans that are initialed and include the installation date of Best Management Practices. These practices shall include temporary and permanent groundcover and be properly updated to reflect necessary plan and field changes for use and review by Department personnel as well as regulatory agencies.
- (2) Requirements set forth under the NPDES Permit - The Department's NPDES Stormwater permit (NCS000250) outlines certain objectives and management measures pertaining to construction activities. The permit references *NCG010000, General Permit to Discharge Stormwater* under the NPDES, and states that the Department shall incorporate the applicable requirements into its delegated Erosion and Sediment Control Program for construction activities disturbing one or more acres of land. The Department further incorporates these requirements on all contracted bridge and culvert work at jurisdictional waters, regardless of size. Some of the requirements are, but are not limited to:
- (a) Control project site waste to prevent contamination of surface or ground waters of the state, i.e. from equipment operation/maintenance, construction materials, concrete washout, chemicals, litter, fuels, lubricants, coolants, hydraulic fluids, any other petroleum products, and sanitary waste.
 - (b) Inspect erosion and sediment control/stormwater devices and stormwater discharge outfalls at least once every 7 calendar days, twice weekly for construction related *Federal Clean Water Act, Section 303(d)* impaired streams with turbidity violations, and within 24 hours after a significant rainfall event of 0.5 inch that occurs within a 24 hour period.
 - (c) Maintain an onsite rain gauge or use the Department's Multi-Sensor Precipitation Estimate website to maintain a daily record of rainfall amounts and dates.
 - (d) Maintain erosion and sediment control/stormwater inspection records for review by Department and Regulatory personnel upon request.
 - (e) Implement approved reclamation plans on all borrow pits, waste sites and staging areas.

- (f) Maintain a log of turbidity test results as outlined in the Department's Procedure for Monitoring Borrow Pit Discharge.
 - (g) Provide secondary containment for bulk storage of liquid materials.
 - (h) Provide training for employees concerning general erosion and sediment control/stormwater awareness, the Department's NPDES Stormwater Permit NCS000250 requirements, and the applicable requirements of the *General Permit, NCG010000*.
 - (i) Report violations of the NPDES permit to the Engineer immediately who will notify the Division of Water Quality Regional Office within 24 hours of becoming aware of the violation.
- (3) Quality Control Program - Maintain a quality control program to control erosion, prevent sedimentation and follow provisions/conditions of permits. The quality control program shall:
- (a) Follow permit requirements related to the Contractor and subcontractors' construction activities.
 - (b) Ensure that all operators and subcontractors on site have the proper erosion and sediment control/stormwater certification.
 - (c) Notify the Engineer when the required certified erosion and sediment control/stormwater personnel are not available on the job site when needed.
 - (d) Conduct the inspections required by the NPDES permit.
 - (e) Take corrective actions in the proper timeframe as required by the NPDES permit for problem areas identified during the NPDES inspections.
 - (f) Incorporate erosion control into the work in a timely manner and stabilize disturbed areas with mulch/seed or vegetative cover on a section-by-section basis.
 - (g) Use flocculants approved by state regulatory authorities where appropriate and where required for turbidity and sedimentation reduction.
 - (h) Ensure proper installation and maintenance of temporary erosion and sediment control devices.
 - (i) Remove temporary erosion or sediment control devices when they are no longer necessary as agreed upon by the Engineer.
 - (j) The Contractor's quality control and inspection procedures shall be subject to review by the Engineer. Maintain NPDES inspection records and make records available at all times for verification by the Engineer.
- (B) *Certified Foreman* - At least one Certified Foreman shall be onsite for each type of work listed herein during the respective construction activities to control erosion, prevent sedimentation and follow permit provisions:
- (1) Foreman in charge of grading activities
 - (2) Foreman in charge of bridge or culvert construction over jurisdictional areas
 - (3) Foreman in charge of utility activities

The Contractor may request to use the same person as the Level II Supervisor and Level II Foreman. This person shall be onsite whenever construction activities as described above are taking place. This request shall be approved by the Engineer prior to work beginning.

The Contractor may request to name a single Level II Foreman to oversee multiple construction activities on small bridge or culvert replacement projects. This request shall be approved by the Engineer prior to work beginning.

(C) *Certified Installers* - Provide at least one onsite, Level I Certified Installer for each of the following erosion and sediment control/stormwater crew:

- (1) Seeding and Mulching
- (2) Temporary Seeding
- (3) Temporary Mulching
- (4) Sodding
- (5) Silt fence or other perimeter erosion/sediment control device installations
- (6) Erosion control blanket installation
- (7) Hydraulic tackifier installation
- (8) Turbidity curtain installation
- (9) Rock ditch check/sediment dam installation
- (10) Ditch liner/matting installation
- (11) Inlet protection
- (12) Riprap placement
- (13) Stormwater BMP installations (such as but not limited to level spreaders, retention/detention devices)
- (14) Pipe installations within jurisdictional areas

If a Level I *Certified Installer* is not onsite, the Contractor may substitute a Level II Foreman for a Level I Installer, provided the Level II Foreman is not tasked to another crew requiring Level II Foreman oversight.

(D) *Certified Designer* - Include the certification number of the Level III Certified Designer on the erosion and sediment control/stormwater component of all reclamation plans and if applicable, the certification number of the Level III Certified Designer on the design of the project erosion and sediment control/stormwater plan.

Preconstruction Meeting

Furnish the names of the *Certified Erosion and Sediment Control/Stormwater Supervisor*, *Certified Foremen*, *Certified Installers* and *Certified Designer* and notify the Engineer of changes in certified personnel over the life of the contract within 2 days of change.

Ethical Responsibility

Any company performing work for the North Carolina Department of Transportation has the ethical responsibility to fully disclose any reprimand or dismissal of an employee resulting from improper testing or falsification of records.

Revocation or Suspension of Certification

Upon recommendation of the Chief Engineer to the certification entity, certification for *Supervisor, Certified Foremen, Certified Installers* and *Certified Designer* may be revoked or suspended with the issuance of an *Immediate Corrective Action (ICA)*, *Notice of Violation (NOV)*, or *Cease and Desist Order* for erosion and sediment control/stormwater related issues.

The Chief Engineer may recommend suspension or permanent revocation of certification due to the following:

- (A) Failure to adequately perform the duties as defined within this certification provision.
- (B) Issuance of an ICA, NOV, or Cease and Desist Order.
- (C) Failure to fully perform environmental commitments as detailed within the permit conditions and specifications.
- (D) Demonstration of erroneous documentation or reporting techniques.
- (E) Cheating or copying another candidate's work on an examination.
- (F) Intentional falsification of records.
- (G) Directing a subordinate under direct or indirect supervision to perform any of the above actions.
- (H) Dismissal from a company for any of the above reasons.
- (I) Suspension or revocation of one's certification by another entity.

Suspension or revocation of a certification will be sent by certified mail to the certificant and the Corporate Head of the company that employs the certificant.

A certificant has the right to appeal any adverse action which results in suspension or permanent revocation of certification by responding, in writing, to the Chief Engineer within 10 calendar days after receiving notice of the proposed adverse action.

Chief Engineer
1536 Mail Service Center
Raleigh, NC 27699-1536

Failure to appeal within 10 calendar days will result in the proposed adverse action becoming effective on the date specified on the certified notice. Failure to appeal within the time specified will result in a waiver of all future appeal rights regarding the adverse action taken. The certificant will not be allowed to perform duties associated with the certification during the appeal process.

The Chief Engineer will hear the appeal and make a decision within 7 days of hearing the appeal. Decision of the Chief Engineer will be final and will be made in writing to the certificant.

If a certification is temporarily suspended, the certificant shall pass any applicable written examination and any proficiency examination, at the conclusion of the specified suspension period, prior to having the certification reinstated.

Measurement and Payment

Certified Erosion and Sediment Control/Stormwater Supervisor, Certified Foremen, Certified Installers and Certified Designer will be incidental to the project for which no direct compensation will be made.

PROCEDURE FOR MONITORING BORROW PIT DISCHARGE:

(2-20-07) (Rev. 3-19-13)

105-16, 230, 801

SP1 G181

Water discharge from borrow pit sites shall not cause surface waters to exceed 50 NTUs (nephelometric turbidity unit) in streams not designated as trout waters and 10 NTUs in streams, lakes or reservoirs designated as trout waters. For lakes and reservoirs not designated as trout waters, the turbidity shall not exceed 25 NTUs. If the turbidity exceeds these levels due to natural background conditions, the existing turbidity level shall not be increased.

If during any operating day, the downstream water quality exceeds the standard, the Contractor shall do all of the following:

- (A) Either cease discharge or modify the discharge volume or turbidity levels to bring the downstream turbidity levels into compliance, or
- (B) Evaluate the upstream conditions to determine if the exceedance of the standard is due to natural background conditions. If the background turbidity measurements exceed the standard, operation of the pit and discharge can continue as long as the stream turbidity levels are not increased due to the discharge.
- (C) Measure and record the turbidity test results (time, date and sampler) at all defined sampling locations 30 minutes after startup and at a minimum, one additional sampling of all sampling locations during that 24-hour period in which the borrow pit is discharging.
- (D) Notify DWQ within 24 hours of any stream turbidity standard exceedances that are not brought into compliance.

During the Environmental Assessment required by Article 230-4 of the *2012 Standard Specifications*, the Contractor shall define the point at which the discharge enters into the State's surface waters and the appropriate sampling locations. Sampling locations shall include points upstream and downstream from the point at which the discharge enters these waters. Upstream sampling location shall be located so that it is not influenced by backwater conditions and represents natural background conditions. Downstream sampling location shall be located at the point where complete mixing of the discharge and receiving water has occurred.

The discharge shall be closely monitored when water from the dewatering activities is introduced into jurisdictional wetlands. Any time visible sedimentation (deposition of sediment) on the wetland surface is observed, the dewatering activity will be suspended until turbidity levels in the stilling basin can be reduced to a level where sediment deposition does not occur. Staining of wetland surfaces from suspended clay particles, occurring after evaporation or infiltration, does not constitute sedimentation. No activities shall occur in wetlands that adversely affect the functioning of a wetland. Visible sedimentation will be considered an indication of possible adverse impacts on wetland use.

The Engineer will perform independent turbidity tests on a random basis. These results will be maintained in a log within the project records. Records will include, at a minimum, turbidity test results, time, date and name of sampler. Should the Department's test results exceed those of the Contractor's test results, an immediate test shall be performed jointly with the results superseding the previous test results of both the Department and the Contractor.

The Contractor shall use the *NCDOT Turbidity Reduction Options for Borrow Pits Matrix*, available at http://www.ncdot.gov/doh/operations/dp_chief_eng/roadside/fieldops/downloads/Files/TurbidityReductionOptionSheet.pdf to plan, design, construct, and maintain BMPs to address water quality standards. Tier I Methods include stilling basins which are standard compensatory BMPs. Other Tier I methods are noncompensatory and shall be used when needed to meet the stream turbidity standards. Tier II Methods are also noncompensatory and are options that may be needed for protection of rare or unique resources or where special environmental conditions exist at the site which have led to additional requirements being placed in the DWQ's 401 Certifications and approval letters, Isolated Wetland Permits, Riparian Buffer Authorization or a DOT Reclamation Plan's Environmental Assessment for the specific site. Should the Contractor exhaust all Tier I Methods on a site exclusive of rare or unique resources or special environmental conditions, Tier II Methods may be required by regulators on a case by case basis per supplemental agreement.

The Contractor may use cation exchange capacity (CEC) values from proposed site borings to plan and develop the bid for the project. CEC values exceeding 15 milliequivalents per 100 grams of soil may indicate a high potential for turbidity and should be avoided when dewatering into surface water is proposed.

No additional compensation for monitoring borrow pit discharge will be paid.

EMPLOYMENT:

(11-15-11) (Rev. 1-17-12)

108, 102

SP1 G184

Revise the *2012 Standard Specifications* as follows:

Page 1-20, Subarticle 102-15(O), delete and replace with the following:

(O) Failure to restrict a former Department employee as prohibited by Article 108-5.

Page 1-65, Article 108-5 Character of Workmen, Methods, and Equipment, line 32, delete all of line 32, the first sentence of the second paragraph and the first word of the second sentence of the second paragraph.

STATE HIGHWAY ADMINISTRATOR TITLE CHANGE:

(9-18-12)

SP1 G185

Revise the *2012 Standard Specifications* as follows:

Replace all references to “State Highway Administrator” with “Chief Engineer”.

SUBLETTING OF CONTRACT:

(11-18-2014)

108-6

SP1 G186

Revise the *2012 Standard Specifications* as follows:

Page 1-66, Article 108-6 Subletting of Contract, line 37, add the following as the second sentence of the first paragraph:

All requests to sublet work shall be submitted within 30 days of the date of availability or prior to expiration of 20% of the contract time, whichever date is later, unless otherwise approved by the Engineer.

Page 1-67, Article 108-6 Subletting of Contract, line 7, add the following as the second sentence of the fourth paragraph:

Purchasing materials for subcontractors is not included in the percentage of work required to be performed by the Contractor. If the Contractor sublets items of work but elects to purchase material for the subcontractor, the value of the material purchased will be included in the total dollar amount considered to have been sublet.

PROJECT SPECIAL PROVISIONS**ROADWAY****CLEARING AND GRUBBING - METHOD III:**

(4-6-06) (Rev.8-18-15)

200

SP2 R02B

Perform clearing on this project to the limits established by Method "III" shown on Standard Drawing No. 200.03 of the *2012 Roadway Standard Drawings*. Conventional clearing methods may be used except where permit drawings or conditions have been included in the proposal which require certain areas to be cleared by hand methods.

BURNING RESTRICTIONS:

(7-1-95)

200, 210, 215

SP2 R05

Open burning is not permitted on any portion of the right-of-way limits established for this project. Do not burn the clearing, grubbing or demolition debris designated for disposal and generated from the project at locations within the project limits, off the project limits or at any waste or borrow sites in this county. Dispose of the clearing, grubbing and demolition debris by means other than burning, according to state or local rules and regulations.

SHOULDER AND FILL SLOPE MATERIAL:

(5-21-02)

235, 560

SP2 R45 B

Description

Perform the required shoulder and slope construction for this project in accordance with the applicable requirements of Section 560 and Section 235 of the *2012 Standard Specifications*.

Measurement and Payment

When the Contractor elects to obtain material from an area located beneath a proposed fill sections which does not require excavation for any reason other than to generate acceptable shoulder and fill slope material, the work of performing the excavation will be considered incidental to the item of *Borrow Excavation* or *Shoulder Borrow*. If there is no pay item for *Borrow* or *Shoulder Borrow* in the contract, this work will be considered incidental to *Unclassified Excavation*. Stockpile the excavated material in a manner to facilitate measurement by the Engineer. Fill the void created by the excavation of the shoulder and fill slope material with suitable material. Payment for material used from the stockpile will be made at the contract unit price for *Borrow Excavation* or *Shoulder Borrow*. If there is no pay item for *Borrow Excavation* or *Shoulder Borrow*, then the material will be paid for at the contract unit price for *Unclassified Excavation*. The material used to fill the void created by the excavation of the shoulder and fill slope material will be made at the contract unit price for *Unclassified Excavation*, *Borrow Excavation*, or *Shoulder Borrow*, depending on the source of the material.

Material generated from undercut excavation, unclassified excavation or clearing and grubbing operations that is placed directly on shoulders or slope areas, will not be measured separately for

payment, as payment for the work requiring the excavation will be considered adequate compensation for depositing and grading the material on the shoulders or slopes.

When undercut excavation is performed at the direction of the Engineer and the material excavated is found to be suitable for use as shoulder and fill slope material, and there is no area on the project currently prepared to receive the material generated by the undercut operation, the Contractor may construct a stockpile for use as borrow at a later date. Payment for the material used from the stockpile will be made at the contract unit price for *Borrow Excavation* or *Shoulder Borrow*.

When shoulder material is obtained from borrow sources or from stockpiled material, payment for the work of shoulder construction will be made at the contract unit price per cubic yard for *Borrow Excavation* or *Shoulder Borrow* in accordance with the applicable provisions of Section 230 or Section 560 of the *2012 Standard Specifications*.

COAL COMBUSTION PRODUCTS IN EMBANKMENTS:

(4-16-02) (Rev. 5-19-15)

235

SP02 R70

Description

This specification allows the Contractor an option, with the approval of the Engineer, to use coal combustion products (CCPs) in embankments as a substitute for conventional borrow material. The amount of CCPs allowed to be used for this project will be less than 80,000 tons total and less than 8,000 tons per acre.

Materials

Supply coal combustion products from the Department list of potential suppliers maintained by the Value Management Unit. Site specific approval of CCP material will be required prior to beginning construction.

The following CCPs are unacceptable:

- (A) Frozen material,
- (B) Ash from boilers fired with both coal and petroleum coke, and
- (C) Material with a maximum dry unit weight of less than 65 pounds per cubic foot when tested in accordance with AASHTO T-99 Method A or C.

Collect and transport CCPs in a manner that will prevent nuisances and hazards to public health and safety. Moisture condition the CCPs as needed and transport in covered trucks to prevent dusting.

Preconstruction Requirements

When CCPs are to be used as a substitute for earth borrow material, request written approval from the Engineer at least ninety (90) days in advance of the intent to use CCPs and include the following details using the NCDOT Form #CCP-2015-V1 in accordance with NCGS § 130A-309.215(b)(1):

- (A) Description, purpose and location of project.
- (B) Estimated start and completion dates of project.
- (C) Estimated volume of CCPs to be used on project with specific locations and construction details of the placement.
- (D) Toxicity Characteristic Leaching Procedure analysis from a representative sample of each different CCP source to be used in the project for, at minimum, all of the following constituents: arsenic, barium, cadmium, lead, chromium, mercury, selenium, and silver.
- (E) The names, address, and contact information for the generator of the CCPs.
- (F) Physical location of the project at which the CCPs were generated.

Submit the form to the Engineer and the State Value Management Engineer at valuemanagementunit@ncdot.gov for review. The Engineer and the State Value Management Engineer will coordinate the requirements of NCGS § 130A-309.215(a)(1) and notify the Contractor that all the necessary requirements have been met before the placement of structural fill using coal combustion products is allowed.

Construction Methods

In accordance with the detail in the plans, place CCPs in the core of the embankment section with at least 4 feet of earth cover to the outside limits of the embankments or subgrade and at least 5 feet above the seasonal high ground-water table. CCPs used in embankments shall not be placed as follows:

- (A) Within 50 feet of any property boundary.
- (B) Within 300 horizontal feet of a private dwelling or well.
- (C) Within 50 horizontal feet of the top of the bank of a perennial stream or other surface water body.
- (D) Within a 100-year floodplain except as authorized under NCGS § 143-215.54A(b). A site located in a floodplain shall not restrict the flow of the 100-year floodplain or result in washout of solid waste so as to pose a hazard to human life, wildlife or land and water resources.
- (E) Within 50 horizontal feet of a wetland, unless, after consideration of the chemical and physical impact on the wetland, the United States Army Corps of Engineers issues a permit or waiver for the fill.

Construct embankments by placing CCPs in level uniform lifts with no more than a lift of 10 inches and compacted to at least a density of 95 percent as determined by test methods in AASHTO T-99, Determination of Maximum Dry Density and Optimum Moisture Content, Method A or C depending upon particle size of the product. Provide a moisture content at the time of compaction of within 4 percent of optimum but not greater than one percent above optimum as determined by AASHTO T-99, Method A or C.

Divert surface waters resulting from precipitation from the CCPs placement area during filling and construction activities. Construct embankments such that rainfall will not run directly off of the CCPs. Provide dust control to minimize airborne emissions. Construct fill in a manner that

prevents water from accumulating and ponding and do not pump nor discharge waters from CCP's filling and construction areas.

Measurement and Payment

Borrow Excavation will be measured by truck volume and paid in cubic yards in accordance with Article 230-5 of the *2012 Standard Specifications*.

ROCK AND BROKEN PAVEMENT FILLS:

(2-16-16)

235

SP2 R85

Revise the *2012 Standard Specifications* as follows:

Page 2-22, Article 235-2 MATERIALS, add the following after line 19:

Item	Section
Geotextile for Rock and Broken Pavement Fills, Type 2	1056

Provide Type 2 geotextile for filtration geotextiles. Use rip rap and No. 57 stone from either a quarry or onsite material to fill voids in rock and broken pavement fills. Provide small and large size rip rap with stone sizes that meet Class A and B in accordance with Table 1042-1 and No. 57 stone with a gradation that meets Table 1005-1 or use similar size onsite material approved by the Engineer.

Page 2-23, Subarticle 235-3(B) Embankment Formation, lines 18-19, delete the third sentence in the seventh paragraph.

Page 2-23, Subarticle 235-3(B) Embankment Formation, lines 21-23, replace the eighth paragraph with the following:

Before placing embankment fill material or filtration geotextiles over rock and broken pavement, fill voids in the top of rock and broken pavement fill with rip rap and No. 57 stone. Place and compact larger rip rap first followed by smaller rip rap. Then, fill any remaining voids with No. 57 stone so geotextiles are not torn, ripped or otherwise damaged when installed and covered. Compact rip rap and No. 57 stone with tracked equipment or other approved methods. Install filtration geotextiles on top of rock, broken pavement, rip rap and No. 57 stone in accordance with Article 270-3 before placing remaining embankment fill material.

Remove any rocks, debris or pavement pieces from the roadbed larger than 2" within 12" of the subgrade or finished grade, whichever is lower.

Page 2-24, Article 235-5 MEASUREMENT AND PAYMENT, line 13, add the following to the end of the first paragraph:

Payment for rip rap, No. 57 stone and geotextiles to construct embankments with rock and broken pavement fills will be considered incidental to the work in Sections 225, 226, 230 and 240.

BLASTING:

(2-16-16)

220

SP2 R88B

Revise the *2012 Standard Specifications* as follows:

Page 2-8, Article 220-1 DESCRIPTION, line 22, delete “cushion, ”.

Page 2-8, Article 220-1 DESCRIPTION, line 23, add the following after the third sentence:

Unless required otherwise in the contract, design blasts for the vibration and air overpressure limits in this section.

Page 2-9, Subarticle 220-3(A) Vibration and Air Overpressure Limits, line 18, add the following to the end of Subarticle 220-3(A):

Unless required otherwise in the contract or directed, design production and trench blasts in accordance with the following:

- (1) Production Blasting
 - (a) For rock cut slopes steeper than 1.5:1 (H:V) without pre-splitting, do not use production blast holes more than 4" in diameter within 10 ft of finished slope faces or neat lines
 - (b) Do not drill production holes below bottom of adjacent pre-split blast holes
 - (c) Use delay blasting to detonate production blast holes towards a free face
- (2) Trench Blasting
 - (a) Do not use trench blast holes more than 3" in diameter
 - (b) Do not use ANFO or other bulk loaded products
 - (c) Use cartridge explosives or other explosive types designed for trench blasting
 - (d) Use charges with a diameter of 1/2" to 3/4" less than the trench blast hole diameter

PIPE INSTALLATION:

(11-20-12) (Rev. 8-18-15)

300

SP3 R01

Revise the *2012 Standard Specifications* as follows:

Page 3-1, Article 300-2, Materials, line 15, in the materials table, replace “Flowable Fill” and “Geotextiles” with the following:

Item	Section
Flowable Fill, Excavatable	1000-6
Grout, Type 2	1003
Geotextiles, Type 4	1056

Page 3-1, Article 300-2, Materials, lines 23-24, replace sentence with the following:

Provide foundation conditioning geotextile and geotextile to wrap pipe joints in accordance with Section 1056 for Type 4 geotextile.

Page 3-3, Subarticle 300-6(A), Rigid Pipe, line 2, in the first paragraph, replace “an approved non-shrink grout.” with “grout.” and line 4, in the second paragraph, replace “filtration geotextile” with “geotextile”.

Page 3-3, Article 300-7, Backfilling, lines 37-38, in the first and second sentences of the fifth paragraph, replace “Excavatable flowable fill” with “Flowable fill”.

WELDED STEEL PIPE UNDER RAILROAD:

The 36" and 48" welded steel pipe required under the tracks of Norfolk Southern Railroad shall conform with Section 330 of the *Standard Specifications*. The thickness of the wall shall be 0.500 inches (36" pipe) and 0.625 inches (48" pipe).

The pipe shall be installed by dry boring and jacking under the tracks as shown in the plans. The pipe shall be carefully dry bored true to the line and grade given. The bore shall be held to a minimum to insure that there will be no settlement. Pipe which has been damaged due to the Contractor's operation shall be removed and replaced at the Contractor's expense. All voids around the outside of the pipe shall be completely filled to the satisfaction of the Engineer.

The Contractor shall notify Mr. Garrett Skipper, Track Supervisor, Norfolk Southern Railroad, 2730 Highland Ave. NE, Hickory, NC, 28601, (828) 326-9136/Office, (540) 589-8548/Cell, (828) 672-0255/FAX, William.Skipper@nscorp.com, 15 days before any work is begun on the railroad's right of way. This will enable them to have a representative present, if they so desire, while the work is being performed to determine if the work is being performed in accordance with the approved plans and Special Provisions. The railroad will advise the Contractor when the work is to be done between trains and provide a flagman, if required.

The quantity of pipe to be paid for will be the actual number of linear feet of pipe which has been incorporated in the completed and accepted work. Measurement will be made by counting the number of joints used and multiplying by the length of the joint. Where partial joints are used, measurement will be made along the longest length of the partial joint to the nearest 0.1 of a foot.

The quantity of pipe measured as provided for above will be paid for at the contract unit price per linear foot for ___" *Welded Steel Pipe*, ___" *Thick, Grade B, (Under RR)*. Such price and payment will be full compensation for all work described herein including dry boring, jacking, tools, materials, labor, workmanship and all other incidentals necessary to complete the work.

The Contractor shall submit two (2) sets of detailed plans and a written description of his proposed method of pipe installation for approval by the Engineer and the Railway Company. Plans should include the size and location of any required jacking pits and shoring for support of the railroad roadbed if necessary.

CORRUGATED ALUMINUM ALLOY PIPE ARCH WITH HEADWALLS:**Description**

Perform the required aluminum alloy pipe arch with headwalls construction in accordance with the detail in the plans, the *2012 Standard Specifications* and this Special Provision.

The work covered by this special provision consists of furnishing all labor, equipment, materials and a manufacturer representative on site, to install the aluminum alloy pipe arch as indicated on the plans and *Standard Specifications*.

Design of the aluminum alloy pipe arch shall be the responsibility of the Contractor and shall comply with the latest AASHTO design specifications and requirements. The Contractor shall submit, fourteen (14) days prior to commencing work at each site, two sets of detailed plans and design calculations that have been checked and sealed by a North Carolina Registered Professional Engineer. The plans should be submitted to the Engineer.

General Aluminum Alloy Pipe Arch Requirements

All items are incidental to aluminum alloy pipe arch:

1. All materials shall meet the requirements of the *2012 Standard Specifications*.
2. Pipe material shall be made of aluminum alloy and in dimensions per the standard specifications and hydraulic recommendations.
3. Poor quality of workmanship of any materials supplied will constitute grounds for the pipe being rejected.
4. Manufacturer's representative, with at least two (2) years of experience in the installation of the type of pipe, is required to provide technical assistance with the assembly of structure and headwalls as well as being on site during the installation and backfilling of pipe with headwalls through completion.
5. Detailed shop drawings and design calculations shall be submitted for acceptance. The supplier shall provide a design that meets the requirements of AASHTO and is sealed by a North Carolina Registered Professional Engineer.
6. Headwalls and baffles shall be constructed in accordance with plans

Payment will be made under:

Pay Item	Pay Unit
95" x 67" Corrugated Aluminum Alloy Pipe Arch, with Headwalls	Linear Foot

BRIDGE APPROACH FILLS:

(10-19-10) (Rev. 1-17-12)

422

SP4 R02

Description

Bridge approach fills include bridge approach fills for sub regional tier bridges and reinforced bridge approach fills. Construct bridge approach fills in accordance with the contract and Standard Drawing No. 422.10 or 422.11 of the *2012 Roadway Standard Drawings*. Define "geosynthetics" as geotextiles or geomembranes.

Materials

Refer to Division 10 of the *2012 Standard Specifications*.

Item	Section
Anchor Pins	1056-2
Geotextiles	1056
Portland Cement Concrete	1000
Select Material	1016
Subsurface Drainage Materials	1044
Wire Staples	1060-8(D)

For bridge approach fills for sub regional tier bridges, provide Type 1 geotextile for filtration geotextiles. For reinforced bridge approach fills, provide Type 5 geotextile for geotextile reinforcement and Type 1 geotextile and No. 78M stone for drains. Use Class B concrete for concrete pads.

Use Class III or V select material for reinforced bridge approach fills and only Class V select material (standard size No. 78M stone) for bridge approach fills for sub regional tier bridges. Provide PVC pipes, fittings and outlet pipes for subsurface drainage materials. For drains and PVC pipes behind end bents, use pipes with perforations that meet AASHTO M 278.

Use PVC, HDPE or linear low density polyethylene (LLDPE) geomembranes for reinforced bridge approach fills. For PVC geomembranes, provide grade PVC30 geomembranes that meet ASTM D7176. For HDPE and LLDPE geomembranes, use geomembranes with a nominal thickness of at least 30 mils that meet Geosynthetic Research Institute Standard Specifications GM13 or GM17, respectively. Handle and store geomembranes in accordance with Article 1056-2 of the *2012 Standard Specifications*. Provide material certifications for geomembranes in accordance with Article 1056-3 of the *2012 Standard Specifications*.

Construction Methods

Excavate as necessary for bridge approach fills in accordance with the contract. Notify the Engineer when foundation excavation is complete. Do not place geomembranes or filtration geotextiles until excavation dimensions and foundation material are approved. Attach geomembranes and filtration geotextiles to end bent cap back and wing walls with adhesives, tapes or other approved methods. Glue or weld geomembrane seams to prevent leakage.

For reinforced bridge approach fills, place geotextile reinforcement within 3" of locations shown in Standard Drawing No. 422.10 of the *2012 Roadway Standard Drawings* and in slight tension free of kinks, folds, wrinkles or creases. Install geotextile reinforcement with the orientation, dimensions and number of layers shown in Standard Drawing No. 422.10 of the *2012 Roadway Standard Drawings*. Place first layer of geotextile reinforcement directly on geomembranes with no void or material in between. Install geotextile reinforcement with the machine direction (MD) parallel to the roadway centerline. The MD is the direction of the length or long dimension of the geotextile roll. Do not splice or overlap geotextile reinforcement in the MD so

seams are perpendicular to the roadway centerline. Wrap geotextile reinforcement at end bent cap back and wing walls as shown in Standard Drawing No. 422.10 of the *2012 Roadway Standard Drawings* and directed by the Engineer. Extend geotextile reinforcement at least 4 ft back behind end bent cap back and wing walls into select material.

Overlap adjacent geotextiles at least 18" with seams oriented parallel to the roadway centerline. Hold geotextiles in place with wire staples or anchor pins as needed. Contact the Engineer when existing or future obstructions such as foundations, pavements, pipes, inlets or utilities will interfere with geosynthetics.

For reinforced bridge approach fills, construct one foot square drains consisting of 4" diameter continuous perforated PVC pipes surrounded by No. 78M stone wrapped in Type 1 geotextiles. Install drains in accordance with Standard Drawing No. 422.10 of the *2012 Roadway Standard Drawings*. For bridge approach fills for sub regional tier bridges, install 4" diameter continuous perforated PVC drain pipes in accordance with Standard Drawing No. 422.11 of the *2012 Roadway Standard Drawings*.

Use solvent cement to connect PVC pipes so joints do not leak. Connect perforated pipes to outlet pipes just behind wing walls. Provide drain pipes and drains with positive drainage towards outlets. Place pipe sleeves in or under wing walls for outlet pipes so positive drainage is maintained. Use sleeves that can withstand wing wall loads.

Place select material in 8" to 10" thick lifts. Use only hand operated compaction equipment to compact select material for bridge approach fills. Compact Class III select material in accordance with Subarticle 235-3(C) of the *2012 Standard Specifications*. Compact No. 78M stone with a vibratory compactor to the satisfaction of the Engineer. Do not displace or damage geosynthetics, drain pipes or drains when placing and compacting select material. End dumping directly on geosynthetics is not permitted. Do not operate heavy equipment on geosynthetics, drain pipes or drains until they are covered with at least 8" of select material. Replace any damaged geosynthetics, drain pipes or drains to the satisfaction of the Engineer.

Cover open ends of outlet pipes with rodent screens as shown in Standard Drawing No. 815.03 of the *2012 Roadway Standard Drawings*. Connect ends of outlet pipes to concrete pads or existing drainage structures as directed by the Engineer. Construct concrete pads with an Ordinary surface finish that meets Subarticle 825-6(B) of the *2012 Standard Specifications*.

Measurement and Payment

Reinforced Bridge Approach Fill, Station ____ will be paid at the contract lump sum price. The contract lump sum price for *Reinforced Bridge Approach Fill, Station ____* will be full compensation for labor, tools, equipment and reinforced bridge approach fill materials, excavating, backfilling, hauling and removing excavated materials, compacting select material, connecting outlet pipes to existing drainage structures and supplying select materials, geosynthetics, drains, pipe sleeves and outlet components and any incidentals necessary to construct all reinforced bridge approach fills at each bridge.

Bridge Approach Fill - Sub Regional Tier, Station ____ will be paid at the contract lump sum price. The contract lump sum price for *Bridge Approach Fill - Sub Regional Tier, Station ____* will be full compensation for labor, tools, equipment and bridge approach fill materials, excavating, backfilling, hauling and removing excavated materials, compacting No. 78M stone, connecting outlet pipes to existing drainage structures and supplying No. 78M stone, filtration geotextiles, drain pipes, pipe sleeves and outlet components and any incidentals necessary to construct all bridge approach fills at each sub regional tier bridge.

Payment will be made under:

Pay Item	Pay Unit
Reinforced Bridge Approach Fill, Station ____	Lump Sum
Bridge Approach Fill - Sub Regional Tier, Station ____	Lump Sum

CLASS IV SUBGRADE STABILIZATION IN LIEU OF CHEMICAL STABILIZATION:

(6-16-15)

501, 542

SP05 R017

Description

In lieu of chemical stabilization, provide Class IV Subgrade Stabilization by replacing 8” of subgrade soils with geotextile and Class IV select material. This substitution is allowed in full typical section width and cannot result in chemically stabilized sections less than 1,000 feet in length, unless otherwise approved by the Engineer. Notify the Engineer at least 30 days in advance of starting Class IV Subgrade Stabilization in lieu of Chemical Stabilization.

Materials

Refer to the *2012 Standard Specifications*.

Item	Section
Geotextile for Soil Stabilization, Type 4	1056
Select Material, Class IV	1016

Use Class IV Select Material for Class IV Subgrade Stabilization.

Construction Methods

Install geotextile for soil stabilization in accordance with Article 270-3 in the *2012 Standard Specifications*. Place Class IV subgrade stabilization (standard size no. ABC) by end dumping ABC on geotextiles. Do not operate heavy equipment on geotextiles until geotextiles are covered with Class IV subgrade stabilization. Compact ABC to 97% of AASHTO T 180 as modified by the Department.

Maintain Class IV subgrade stabilization in an acceptable condition and minimize the use of heavy equipment on ABC in order to avoid damaging aggregate subgrades. Provide and maintain drainage ditches and drains as required to prevent entrapping water in aggregate subgrades.

Measurement and Payment

Class IV Subgrade Stabilization in Lieu of Chemical Stabilization will be paid at the prices established in the contract that relate to the chemical stabilization type that is being replaced (Lime or Cement). No direct payment will be made for additional excavation required to accommodate this alternate.

The total amount paid for this subgrade stabilization alternative will be limited to the contract amounts per square yard for replacement for Portland cement or lime, theoretical tons of Portland cement or lime replaced, mixing of cement or lime, and theoretical gallons of asphalt curing seal replaced at the rate of 0.15 gallons per square yard.

A Supplement Agreement will be executed prior to starting the work to create a square yard price for the *Class IV Subgrade Stabilization in Lieu of Chemical Stabilization* and deleting the quantities associated with the work being replaced.

ASPHALT PAVEMENTS - SUPERPAVE:

(6-19-12) (Rev. 1-19-16)

605, 609, 610, 650

SP6 R01

Revise the *2012 Standard Specifications* as follows:

Page 6-3, Article 605-7, APPLICATION RATES AND TEMPERATURES, replace this article, including Table 605-1, with the following:

Apply tack coat uniformly across the existing surface at target application rates shown in Table 605-1.

TABLE 605-1 APPLICATION RATES FOR TACK COAT	
Existing Surface	Target Rate (gal/sy)
	Emulsified Asphalt
New Asphalt	0.04 ± 0.01
Oxidized or Milled Asphalt	0.06 ± 0.01
Concrete	0.08 ± 0.01

Apply tack coat at a temperature within the ranges shown in Table 605-2. Tack coat shall not be overheated during storage, transport or at application.

Asphalt Material	Temperature Range
Asphalt Binder, Grade PG 64-22	350 - 400°F
Emulsified Asphalt, Grade RS-1H	130 - 160°F
Emulsified Asphalt, Grade CRS-1	130 - 160°F
Emulsified Asphalt, Grade CRS-1H	130 - 160°F
Emulsified Asphalt, Grade HFMS-1	130 - 160°F
Emulsified Asphalt, Grade CRS-2	130 - 160°F

Page 6-7, Article 609-3, FIELD VERIFICATION OF MIXTURE AND JOB MIX FORMULA ADJUSTMENTS, lines 35-37, delete the second sentence of the second paragraph.

Page 6-18, Article 610-1 DESCRIPTION, lines 40-41, delete the last sentence of the last paragraph.

Page 6-19, Subarticle 610-3(A), Mix Design-General, line 5, add the following as the first paragraph:

Warm mix asphalt (WMA) is allowed for use at the Contractor's option in accordance with the NCDOT Approved Products List for WMA Technologies available at:

<https://connect.ncdot.gov/resources/Materials/MaterialsResources/Warm%20Mix%20Asphalt%20Approved%20List.pdf>

Page 6-20, Subarticle 610-3(C), Job Mix Formula (JMF), lines 47-48, replace the last sentence of the third paragraph with the following:

The JMF mix temperature shall be within the ranges shown in Table 610-1 unless otherwise approved.

Page 6-21, Subarticle 610-3(C) Job Mix Formula (JMF), replace Table 610-1 with the following:

Binder Grade	JMF Mix Temperature
PG 58-28; PG 64-22	250 - 290°F
PG 70-22	275- 305°F
PG 76-22	300- 325°F

Page 6-21, Subarticle 610-3(C) Job Mix Formula (JMF), lines 1-2, in the first sentence of the first paragraph, delete “and compaction”. Lines 4-7, delete the second paragraph and replace with the following:

When RAS is used, the JMF mix temperature shall be established at 275°F or higher.

Page 6-22, Article 610-4, WEATHER, TEMPERATURE AND SEASONAL LIMITATIONS FOR PRODUCING AND PLACING ASPHALT MIXTURES, lines 15-17, replace the second sentence of the first paragraph with the following:

Do not place asphalt material when the air or surface temperatures, measured at the location of the paving operation away from artificial heat, do not meet Table 610-5.

Page 6-23, Article 610-4, WEATHER, TEMPERATURE AND SEASONAL LIMITATIONS FOR PRODUCING AND PLACING ASPHALT MIXTURES, replace Table 610-5 with the following:

Asphalt Concrete Mix Type	Minimum Surface and Air Temperature
B25.0B, C	35°F
I19.0B, C, D	35°F
SF9.5A, S9.5B	40°F ^A
S9.5C, S12.5C	45°F ^A
S9.5D, S12.5D	50°F

A. For the final layer of surface mixes containing recycled asphalt shingles (RAS), the minimum surface and air temperature shall be 50°F.

Page 6-23, Subarticle 610-5(A), General, lines 33-34, replace the last sentence of the third paragraph with the following:

Produce the mixture at the asphalt plant within ± 25 °F of the JMF mix temperature. The temperature of the mixture, when discharged from the mixer, shall not exceed 350°F.

Page 6-26, Article 610-7, HAULING OF ASPHALT MIXTURE, lines 22-23, in the fourth sentence of the first paragraph replace “so as to overlap the top of the truck bed and” with “to”. Line 28, in the last paragraph, replace “+15 °F to -25 °F of the specified JMF temperature.” with “ ± 25 °F of the specified JMF mix temperature.”

Page 6-26, Article 610-8, SPREADING AND FINISHING, line 34, add the following new paragraph:

As referenced in Section 9.6.3 of the *HMA/QMS Manual*, use the automatic screed controls on the paver to control the longitudinal profile. Where approved by the Engineer, the Contractor has the option to use either a fixed or mobile string line.

Page 6-29, Article 610-13, FINAL SURFACE TESTING AND ACCEPTANCE, line 39, add the following after the first sentence in the first paragraph:

Smoothness acceptance testing using the inertial profiler is not required on ramps, loops and turn lanes.

Page 6-30, Subarticle 610-13(A), Option 1 – Inertial Profiler, lines 15-16, replace the fourth sentence of the fourth paragraph with the following:

The interval at which relative profile elevations are reported shall be 2”.

Page 6-30, Subarticle 610-13(A), Option 1 – Inertial Profiler, lines 25-28, replace the ninth paragraph with the following:

Operate the profiler at any speed as per the manufacturer’s recommendations to collect valid data.

Page 6-30, Subarticle 610-13(A), Option 1 – Inertial Profiler, lines 30-31, delete the third sentence of the tenth paragraph.

Page 6-31, Subarticle 610-13(A), Option 1 – Inertial Profiler, lines 11-13, replace the first sentence of the third paragraph with the following:

After testing, transfer the profile data from the profiler portable computer’s hard drive to a write once storage media (Flash drive, USB, DVD-R or CD-R) or electronic media approved by the Engineer.

Page 6-31, Subarticle 610-13(A), Option 1 – Inertial Profiler, lines 17-18, replace the first sentence of the fourth paragraph with the following:

Submit a report with the documentation and electronic data of the evaluation for each section to the Engineer within 10 days after completion of the smoothness testing. The report shall be in the tabular format for each 0.10 segment or a portion thereof with a summary of the MRI values and the localized roughness areas including corresponding project station numbers or acceptable reference points. Calculate the pay adjustments for all segments in accordance with the formulas in Sections (1) and (2) shown below. The Engineer shall review and approval all pay adjustments unless corrective action is required.

Page 6-31, Subarticle 610-13(A)(1), Acceptance for New Construction, lines 36-37, replace the third paragraph with the following:

The price adjustment will apply to each 0.10-mile section or prorated for a portion thereof, based on the Mean Roughness Index (MRI), the average IRI values from both wheel paths.

Page 6-32, Subarticle 610-13(A)(2), Localized Roughness, lines 12-16, replace the first paragraph with the following:

Areas of localized roughness shall be identified through the “Smoothness Assurance Module (SAM)” provided in the ProVAL software. Use the SAM report to optimize repair strategies by analyzing the measurements from profiles collected using inertial profilers. The ride quality threshold for localized roughness shall be 165 in/mile for any sections that are 15 ft. to 100 ft. in length at the continuous short interval of 25 ft. Submit a continuous roughness report to identify each section with project station numbers or reference points outside the threshold and identify all localized roughness, with the signature of the Operator included with the submitted IRI trace and electronic files.

Page 6-32, Subarticle 610-13(A)(2), Localized Roughness, line 21, add the following new paragraph:

If the Engineer does not require corrective action, the pay adjustment for each area of localized roughness shall be based on the following formula:

$$PA = (165 - LR\#) 5$$

Where:

PA	=	Pay Adjustment (dollars)
LR#	=	The Localized Roughness number determined from SAM report for the ride quality threshold

Page 6-41, Subarticle 650-3(B), Mix Design Criteria, replace Table 650-1 with the following:

TABLE 650-1 OGAFC GRADATION CRITERIA			
<i>Sieve Size (mm)</i>	<i>Type FC-1</i>	<i>Type FC-1 Modified</i>	<i>Type FC-2 Modified</i>
19.0	-	-	100
12.5	100	100	80 - 100
9.50	75 - 100	75 - 100	55 - 80
4.75	25 - 45	25 - 45	15 - 30
2.36	5 - 15	5 - 15	5 - 15
0.075	1.0 - 3.0	1.0 - 3.0	2.0 - 4.0

ASPHALT BINDER CONTENT OF ASPHALT PLANT MIXES:

(11-21-00) (Rev. 7-17-12)

609

SP6 R15

The approximate asphalt binder content of the asphalt concrete plant mixtures used on this project will be as follows:

Asphalt Concrete Base Course	Type B 25.0__	4.4%
Asphalt Concrete Intermediate Course	Type I 19.0__	4.8%
Asphalt Concrete Surface Course	Type S 4.75A	6.8%
Asphalt Concrete Surface Course	Type SA-1	6.8%
Asphalt Concrete Surface Course	Type SF 9.5A	6.7%
Asphalt Concrete Surface Course	Type S 9.5__	6.0%
Asphalt Concrete Surface Course	Type S 12.5__	5.6%

The actual asphalt binder content will be established during construction by the Engineer within the limits established in the *2012 Standard Specifications*.

ASPHALT PLANT MIXTURES:

(7-1-95)

609

SP6 R20

Place asphalt concrete base course material in trench sections with asphalt pavement spreaders made for the purpose or with other equipment approved by the Engineer.

PRICE ADJUSTMENT - ASPHALT BINDER FOR PLANT MIX:

(11-21-00)

620

SP6 R25

Price adjustments for asphalt binder for plant mix will be made in accordance with Section 620 of the *2012 Standard Specifications*.

The base price index for asphalt binder for plant mix is **\$ 350.36** per ton.

This base price index represents an average of F.O.B. selling prices of asphalt binder at supplier's terminals on **March 1, 2016**.

GUARDRAIL ANCHOR UNITS, TYPE 350 (TL-3):

(4-20-04) (Rev. 7-21-15)

862

SP08 R065

Description

Furnish and install guardrail anchor units in accordance with the details in the plans, the applicable requirements of Section 862 of the *2012 Standard Specifications*, and at locations shown in the plans.

Materials

Furnish guardrail anchor units listed on the NCDOT Approved Products List at <https://apps.dot.state.nc.us/vendor/approvedproducts/> or approved equal.

Prior to installation the Contractor shall submit to the Engineer:

- (A) FHWA acceptance letter for each guardrail anchor unit certifying it meets the requirements of NCHRP Report 350, Test Level 3, in accordance with Article 106-2 of the *2012 Standard Specifications*.
- (B) Certified working drawings and assembling instructions from the manufacturer for each guardrail anchor unit in accordance with Article 105-2 of the *2012 Standard Specifications*.

No modifications shall be made to the guardrail anchor unit without the express written permission from the manufacturer. Perform installation in accordance with the details in the plans, and details and assembling instructions furnished by the manufacturer.

Construction Methods

Guardrail end delineation is required on all approach and trailing end sections for both temporary and permanent installations. Guardrail end delineation consists of yellow reflective sheeting applied to the entire end section of the guardrail in accordance with Article 1088-3 of the *2012 Standard Specifications* and is incidental to the cost of the guardrail anchor unit.

Measurement and Payment

Measurement and payment will be made in accordance with Article 862-6 of the *2012 Standard Specifications*.

Payment will be made under:

Pay Item
Guardrail Anchor Units, Type 350

Pay Unit
Each

PREFORMED SCOUR HOLE WITH LEVEL SPREADER APRON:

(10-15-02) (Rev. 10-20-09)

410

SP8 R105

Description

Construct and maintain preformed scour holes with spreader aprons at the locations shown on the plans and in accordance with the details in the plans. Work includes excavation, shaping and maintaining the hole and apron, furnishing and placing filter fabric, rip rap (class as specified in the plans) and permanent soil reinforcement matting.

Materials

Item	Section
Plain Rip Rap	1042
Filter Fabric	1056

The permanent soil reinforcement matting shall be permanent erosion control reinforcement mat and shall be constructed of synthetic or a combination of coconut and synthetic fibers evenly distributed throughout the mat between a bottom UV stabilized netting and a heavy duty UV stabilized top net. The matting shall be stitched together with UV stabilized polypropylene thread to form a permanent three dimensional structure. The mat shall have the following minimum physical properties:

Property	Test Method	Value Unit
Light Penetration	ASTM D6567	9 %
Thickness	ASTM D6525	0.40 in
Mass Per Unit Area	ASTM D6566	0.55 lb/sy
Tensile Strength	ASTM D6818	385 lb/ft
Elongation (Maximum)	ASTM D6818	49 %
Resiliency	ASTM D1777	>70 %
UV Stability *	ASTM 4355	≥80 %
Porosity (Permanent Net)	ECTC Guidelines	≥85 %
Maximum Permissible Shear Stress (Vegetated)	Performance Bench Test	≥8.0 lb/ft ²
Maximum Allowable Velocity (Vegetated)	Performance Bench Test	≥16.0 ft/s

*ASTM D1682 Tensile Strength and % strength retention of material after 1,000 hours of exposure.

Submit a certification (Type 1, 2, or 3) from the manufacturer showing:

- (A) The chemical and physical properties of the mat used, and
- (B) Conformance of the mat with this specification.

Construction Methods

All areas to be protected with the mat shall be brought to final grade and seeded in accordance with Section 1660 of the *2012 Standard Specifications*. The surface of the soil shall be smooth, firm, stable and free of rocks, clods, roots or other obstructions that would prevent the mat from lying in direct contact with the soil surface. Areas where the mat is to be placed will not need to be mulched.

Measurement and Payment

Performed Scour Holes with Level Spreader Aprons will be measured and paid as the actual number incorporated into the completed and accepted work. Such price and payment will be full compensation for all work covered by this provision.

Payment will be made under:

Pay Item	Pay Unit
Performed Scour Hole with Level Spreader Aprons	Each

DETECTABLE WARNINGS FOR PROPOSED CURB RAMPS:

(6-15-10) (Rev. 8-16-11)

848

SP8 R126

Description

Construct detectable warnings consisting of integrated raised truncated domes on proposed concrete curb ramps in accordance with the *2012 Standard Specifications*, plan details, the requirements of the *28 CFR Part 36 ADA Standards for Accessible Design* and this provision.

Materials

Detectable warning for proposed curb ramps shall consist of integrated raised truncated domes. The description, size and spacing shall conform to Section 848 of the *2012 Standard Specifications*.

Use material for detectable warning systems as shown herein. Material and coating specifications must be stated in the Manufacturers Type 3 Certification and all Detectable Warning systems must be on the NCDOT Approved Products List.

Install detectable warnings created from one of the following materials: precast concrete blocks or bricks, clay paving brick, gray or ductile iron castings, mild steel, stainless steel, and engineered plastics, rubber or composite tile. Only one material type for detectable warning will be permitted per project, unless otherwise approved by the Engineer.

- (A) Detectable Warnings shall consist of a base with integrated raised truncated domes, and when constructed of precast concrete they shall conform to the material requirements of Article 848-2 of the *2012 Standard Specifications*.

- (B) Detectable Warnings shall consist of a base with integrated raised truncated domes, and may be comprised of other materials including, but not limited, to clay paving brick, gray iron or ductile iron castings, mild steel, stainless steel, and engineered plastics, rubber or composite tile, which are cast into the concrete of the curb ramps. The material shall have an integral color throughout the thickness of the material. The detectable warning shall include fasteners or anchors for attachment in the concrete and shall be furnished as a system from the manufacturer.

Prior to installation, the Contractor shall submit to the Engineer assembling instructions from the manufacturer for each type of system used in accordance with Article 105-2 of the *2012 Standard Specifications*. The system shall be furnished as a kit containing all consumable materials and consumable tools, required for the application. They shall be capable of being affixed to or anchored in the concrete curb ramp, including green concrete (concrete that has set but not appreciably hardened). The system shall be solvent free and contain no volatile organic compounds (VOC). The static coefficient of friction shall be 0.8 or greater when measured on top of the truncated domes and when measured between the domes in accordance with ASTM C1028 (dry and wet). The system shall be resistant to deterioration due to exposure to sunlight, water, salt or adverse weather conditions and impervious to degradation by motor fuels, lubricants and antifreeze.

- (C) When steel or gray iron or ductile iron casting products are provided, only products that meet the requirements of Subarticle 106-1(B) of the *2012 Standard Specifications* may be used. Submit to the Engineer a Type 6 Certification, catalog cuts and installation procedures at least 30 days prior to installation for all.

Construction Methods

- (A) Prior to placing detectable warnings in proposed concrete curb ramps, adjust the existing subgrade to the proper grade and in accordance with Article 848-3 of the *2012 Standard Specifications*.
- (B) Install all detectable warning in proposed concrete curb ramps in accordance with the manufacturer's recommendations.

Measurement and Payment

Detectable Warnings installed for construction of proposed curb ramps will not be paid for separately. Such payment will be included in the price bid for *Concrete Curb Ramps*.

FOUNDATIONS AND ANCHOR ROD ASSEMBLIES FOR METAL POLES:

(1-17-12) (Rev. 5-19-15)

9, 14, 17

SP9 R05

Description

Foundations for metal poles include foundations for signals, cameras, overhead and dynamic message signs (DMS) and high mount and low level light standards supported by metal poles or

upright trusses. Foundations consist of footings with pedestals and drilled piers with or without grade beams or wings. Anchor rod assemblies consist of anchor rods (also called anchor bolts) with nuts and washers on the exposed ends of rods and nuts and a plate or washers on the other ends of rods embedded in the foundation.

Construct concrete foundations with the required resistances and dimensions and install anchor rod assemblies in accordance with the contract and accepted submittals. Construct drilled piers consisting of cast-in-place reinforced concrete cylindrical sections in excavated holes. Provide temporary casings or polymer slurry as needed to stabilize drilled pier excavations. Use a prequalified Drilled Pier Contractor to construct drilled piers for metal poles. Define “excavation” and “hole” as a drilled pier excavation and “pier” as a drilled pier.

This provision does not apply to materials and anchor rod assemblies for standard foundations for low level light standards. See Section 1405 of the *2012 Standard Specifications* and Standard Drawing No. 1405.01 of the *2012 Roadway Standard Drawings* for materials and anchor rod assemblies for standard foundations. For construction of standard foundations for low level light standards, standard foundations are considered footings in this provision.

This provision does not apply to foundations for signal pedestals; see Section 1743 of the *2012 Standard Specifications* and Standard Drawing No. 1743.01 of the *2012 Roadway Standard Drawings*.

Materials

Refer to the *2012 Standard Specifications*.

Item	Section
Conduit	1091-3
Grout, Type 2	1003
Polymer Slurry	411-2(B)
Portland Cement Concrete	1000
Reinforcing Steel	1070
Rollers and Chairs	411-2(C)
Temporary Casings	411-2(A)

Provide Type 3 material certifications in accordance with Article 106-3 of the *2012 Standard Specifications* for conduit, rollers, chairs and anchor rod assemblies. Store steel materials on blocking at least 12" above the ground and protect it at all times from damage; and when placing in the work make sure it is free from dirt, dust, loose mill scale, loose rust, paint, oil or other foreign materials. Load, transport, unload and store foundation and anchor rod assembly materials so materials are kept clean and free of damage. Bent, damaged or defective materials will be rejected.

Use conduit type in accordance with the contract. Use Class A concrete for footings and pedestals, Class Drilled Pier concrete for drilled piers and Class AA concrete for grade beams and wings including portions of drilled piers above bottom of wings elevations. Corrugated

temporary casings may be accepted at the discretion of the Engineer. A list of approved polymer slurry products is available from:

connect.ncdot.gov/resources/Geological/Pages/Products.aspx

Provide anchor rod assemblies in accordance with the contract consisting of the following:

- (A) Straight anchor rods,
- (B) Heavy hex top and leveling nuts and flat washers on exposed ends of rods, and
- (C) Nuts and either flat plates or washers on the other ends of anchor rods embedded in foundations.

Do not use lock washers. Use steel anchor rods, nuts and washers that meet ASTM F1554 for Grade 55 rods and Grade A nuts. Use steel plates and washers embedded in concrete with a thickness of at least 1/4". Galvanize anchor rods and exposed nuts and washers in accordance with Article 1076-4 of the *2012 Standard Specifications*. It is not necessary to galvanize nuts, plates and washers embedded in concrete.

Construction Methods

Install the required size and number of conduits in foundations in accordance with the plans and accepted submittals. Construct top of piers, footings, pedestals, grade beams and wings flat, level and within 1" of elevations shown in the plans or approved by the Engineer. Provide an Ordinary Surface finish in accordance with Subarticle 825-6(B) of the *2012 Standard Specifications* for portions of foundations exposed above finished grade. Do not remove anchor bolt templates or pedestal or grade beam forms or erect metal poles or upright trusses onto foundations until concrete attains a compressive strength of at least 3,000 psi.

(A) Drilled Piers

Before starting drilled pier construction, hold a predrill meeting to discuss the installation, monitoring and inspection of the drilled piers. Schedule this meeting after the Drilled Pier Contractor has mobilized to the site. The Resident or Division Traffic Engineer, Contractor and Drilled Pier Contractor Superintendent will attend this predrill meeting.

Do not excavate holes, install piles or allow equipment wheel loads or vibrations within 20 ft of completed piers until 16 hours after Drilled Pier concrete reaches initial set.

Check for correct drilled pier alignment and location before beginning drilling. Check plumbness of holes frequently during drilling.

Construct drilled piers with the minimum required diameters shown in the plans. Install piers with tip elevations no higher than shown in the plans or approved by the Engineer.

Excavate holes with equipment of the sizes required to construct drilled piers. Depending on the subsurface conditions encountered, drilling through rock and boulders may be required. Do not use blasting for drilled pier excavations.

Contain and dispose of drilling spoils and waste concrete as directed and in accordance with Section 802 of the *2012 Standard Specifications*. Drilling spoils consist of all materials and fluids removed from excavations.

If unstable, caving or sloughing materials are anticipated or encountered, stabilize holes with temporary casings and/or polymer slurry. Do not use telescoping temporary casings. If it becomes necessary to replace a temporary casing during drilling, backfill the excavation, insert a larger casing around the casing to be replaced or stabilize the excavation with polymer slurry before removing the temporary casing.

If temporary casings become stuck or the Contractor proposes leaving casings in place, temporary casings should be installed against undisturbed material. Unless otherwise approved, do not leave temporary casings in place for mast arm poles and cantilever signs. The Engineer will determine if casings may remain in place. If the Contractor proposes leaving temporary casings in place, do not begin drilling until a casing installation method is approved.

Use polymer slurry and additives to stabilize holes in accordance with the slurry manufacturer's recommendations. Provide mixing water and equipment suitable for polymer slurry. Maintain polymer slurry at all times so slurry meets Table 411-3 of the *2012 Standard Specifications* except for sand content.

Define a "sample set" as slurry samples collected from mid-height and within 2 ft of the bottom of holes. Take sample sets from excavations to test polymer slurry immediately after filling holes with slurry, at least every 4 hours thereafter and immediately before placing concrete. Do not place Drilled Pier concrete until both slurry samples from an excavation meet the required polymer slurry properties. If any slurry test results do not meet the requirements, the Engineer may suspend drilling until both samples from a sample set meet the required slurry properties.

Remove soft and loose material from bottom of holes using augers to the satisfaction of the Engineer. Assemble rebar cages and place cages and Drilled Pier concrete in accordance with Subarticle 411-4(E) of the *2012 Standard Specifications* except for the following:

- (1) Inspections for tip resistance and bottom cleanliness are not required,
- (2) Temporary casings may remain in place if approved, and
- (3) Concrete placement may be paused near the top of pier elevations for anchor rod assembly installation and conduit placement or
- (4) If applicable, concrete placement may be stopped at bottom of grade beam or wings elevations for grade beam or wing construction.

If wet placement of concrete is anticipated or encountered, do not place Drilled Pier concrete until a concrete placement procedure is approved. If applicable, temporary casings and fluids may be removed when concrete placement is paused or stopped in accordance with the exceptions above provided holes are stable. Remove contaminated concrete from exposed Drilled Pier concrete after removing casings and fluids. If holes are unstable, do not remove temporary casings until a procedure for placing anchor rod assemblies and conduit or constructing grade beams or wings is approved.

Use collars to extend drilled piers above finished grade. Remove collars after Drilled Pier concrete sets and round top edges of piers.

If drilled piers are questionable, pile integrity testing (PIT) and further investigation may be required in accordance with Article 411-5 of the *2012 Standard Specifications*. A drilled pier will be considered defective in accordance with Subarticle 411-5(D) of the *2012 Standard Specifications* and drilled pier acceptance is based in part on the criteria in Article 411-6 of the *2012 Standard Specifications* except for the top of pier tolerances in Subarticle 411-6(C) of the *2012 Standard Specifications*.

If a drilled pier is under further investigation, do not grout core holes, backfill around the pier or perform any work on the drilled pier until the Engineer accepts the pier. If the drilled pier is accepted, dewater and grout core holes and backfill around the pier with approved material to finished grade. If the Engineer determines a pier is unacceptable, remediation is required in accordance with Article 411-6 of the *2012 Standard Specifications*. No extension of completion date or time will be allowed for remediation of unacceptable drilled piers or post repair testing.

Permanently embed a plate in or mark top of piers with the pier diameter and depth, size and number of vertical reinforcing bars and the minimum compressive strength of the concrete mix at 28 days.

(B) Footings, Pedestals, Grade Beams and Wings

Excavate as necessary for footings, grade beams and wings in accordance with the plans, accepted submittals and Section 410 of the *2012 Standard Specifications*. If unstable, caving or sloughing materials are anticipated or encountered, shore foundation excavations as needed with an approved method. Notify the Engineer when foundation excavation is complete. Do not place concrete or reinforcing steel until excavation dimensions and foundation material are approved.

Construct cast-in-place reinforced concrete footings, pedestals, grade beams and wings with the dimensions shown in the plans and in accordance with Section 825 of the *2012 Standard Specifications*. Use forms to construct portions of pedestals and grade beams protruding above finished grade. Provide a chamfer with a 3/4" horizontal width for pedestal and grade beam edges exposed above finished grade. Backfill and fill in accordance with Article 410-8 of the *2012 Standard Specifications*. Proper compaction

around footings and wings is critical for foundations to resist uplift and torsion forces. Place concrete against undisturbed soil and do not use forms for standard foundations for low level light standards.

(C) Anchor Rod Assemblies

Size anchor rods for design and the required projection above top of foundations. Determine required anchor rod projections from nut, washer and base plate thicknesses, the protrusion of 3 to 5 anchor rod threads above top nuts after tightening and the distance of one nut thickness between top of foundations and bottom of leveling nuts.

Protect anchor rod threads from damage during storage and installation of anchor rod assemblies. Before placing anchor rods in foundations, turn nuts onto and off rods past leveling nut locations. Turn nuts with the effort of one workman using an ordinary wrench without a cheater bar. Report any thread damage to the Engineer that requires extra effort to turn nuts.

Arrange anchor rods symmetrically about center of base plate locations as shown in the plans. Set anchor rod elevations based on required projections above top of foundations. Securely brace and hold rods in the correct position, orientation and alignment with a steel template. Do not weld to reinforcing steel, temporary casings or anchor rods.

Install top and leveling (bottom) nuts, washers and the base plate for each anchor rod assembly in accordance with the following procedure:

- (1) Turn leveling nuts onto anchor rods to a distance of one nut thickness between the top of foundation and bottom of leveling nuts. Place washers over anchor rods on top of leveling nuts.
- (2) Determine if nuts are level using a flat rigid template on top of washers. If necessary, lower leveling nuts to level the template in all directions or if applicable, lower nuts to tilt the template so the metal pole or upright truss will lean as shown in the plans. If leveling nuts and washers are not in full contact with the template, replace washers with galvanized beveled washers.
- (3) Verify the distance between the foundation and leveling nuts is no more than one nut thickness.
- (4) Place base plate with metal pole or upright truss over anchor rods on top of washers. High mount luminaires may be attached before erecting metal poles but do not attach cables, mast arms or trusses to metal poles or upright trusses at this time.
- (5) Place washers over anchor rods on top of base plate. Lubricate top nut bearing surfaces and exposed anchor rod threads above washers with beeswax, paraffin or other approved lubricant.
- (6) Turn top nuts onto anchor rods. If nuts are not in full contact with washers or washers are not in full contact with the base plate, replace washers with galvanized beveled washers.

- (7) Tighten top nuts to snug-tight with the full effort of one workman using a 12" wrench. Do not tighten any nut all at once. Turn top nuts in increments. Follow a star pattern cycling through each nut at least twice.
- (8) Repeat (7) for leveling nuts.
- (9) Replace washers above and below the base plate with galvanized beveled washers if the slope of any base plate face exceeds 1:20 (5%), any washer is not in firm contact with the base plate or any nut is not in firm contact with a washer. If any washers are replaced, repeat (7) and (8).
- (10) With top and leveling nuts snug-tight, mark each top nut on a corner at the intersection of 2 flats and a corresponding reference mark on the base plate. Mark top nuts and base plate with ink or paint that is not water-soluble. Use the turn-of-nut method for pretensioning. Do not pretension any nut all at once. Turn top nuts in increments for a total turn that meets the following nut rotation requirements:

NUT ROTATION REQUIREMENTS (Turn-of-Nut Pretensioning Method)	
Anchor Rod Diameter, inch	Requirement
$\leq 1 \frac{1}{2}$	1/3 turn (2 flats)
$> 1 \frac{1}{2}$	1/6 turn (1 flat)

Follow a star pattern cycling through each top nut at least twice.

- (11) Ensure nuts, washers and base plate are in firm contact with each other for each anchor rod. Cables, mast arms and trusses may now be attached to metal poles and upright trusses.
- (12) Between 4 and 14 days after pretensioning top nuts, use a torque wrench calibrated within the last 12 months to check nuts in the presence of the Engineer. Completely erect mast arm poles and cantilever signs and attach any hardware before checking top nuts for these structures. Check that top nuts meet the following torque requirements:

TORQUE REQUIREMENTS	
Anchor Rod Diameter, inch	Requirement, ft-lb
7/8	180
1	270
1 1/8	380
1 1/4	420
$\geq 1 \frac{1}{2}$	600

If necessary, retighten top nuts in the presence of the Engineer with a calibrated torque wrench to within ± 10 ft-lb of the required torque. Do not overtighten top nuts.

- (13) Do not grout under base plate.

Measurement and Payment

Foundations and anchor rod assemblies for metal poles and upright trusses will be measured and paid for elsewhere in the contract.

No payment will be made for temporary casings that remain in drilled pier excavations. No payment will be made for PIT. No payment will be made for further investigation of defective piers. Further investigation of piers that are not defective will be paid as extra work in accordance with Article 104-7 of the *2012 Standard Specifications*. No payment will be made for remediation of unacceptable drilled piers or post repair testing.

MATERIALS:

(2-21-12) (Rev. 3-15-16)

1000, 1002, 1005, 1016, 1018, 1024, 1050, 1074, 1078, 1080, 1081, 1086, 1084, 1087, 1092

SP10 R01

Revise the *2012 Standard Specifications* as follows:

Page 10-1, Article 1000-1, DESCRIPTION, lines 9-10, replace the last sentence of the first paragraph with the following:

Type IL, IP, IS or IT blended cement may be used instead of Portland cement.

Page 10-1, Article 1000-1, DESCRIPTION, line 14, add the following:

If any change is made to the mix design, submit a new mix design (with the exception of an approved pozzolan source change).

If any major change is made to the mix design, also submit new test results showing the mix design conforms to the criteria. Define a major change to the mix design as:

- (1) A source change in coarse aggregate, fine aggregate or cement.
- (2) A pozzolan class or type change (e.g. Class F fly ash to Class C fly ash).
- (3) A quantitative change in coarse aggregate (applies to an increase or decrease greater than 5%), fine aggregate (applies to an increase or decrease greater than 5%), water (applies to an increase only), cement (applies to a decrease only), or pozzolan (applies to an increase or decrease greater than 5%).

Use materials which do not produce a mottled appearance through rusting or other staining of the finished concrete surface.

Page 10-1, Article 1000-2, MATERIALS, line 16; Page 10-8, Subarticle 1000-7(A), Materials, line 8; and Page 10-18, Article 1002-2, MATERIALS, line 9, add the following to the table of item references:

Item	Section
Type IL Blended Cement	1024-1

Page 10-1, Subarticle 1000-3(A), Composition and Design, lines 25-27, replace the second paragraph with the following:

Fly ash may be substituted for cement in the mix design up to 30% at a rate of 1.0 lb of fly ash to each pound of cement replaced.

Page 10-2, Subarticle 1000-3(A), Composition and Design, lines 12-21, delete the third paragraph through the sixth paragraph beginning with “If any change is made to the mix design, submit...” through “...(applies to a decrease only).”

Page 10-5, Table 1000-1, REQUIREMENTS FOR CONCRETE, replace with the following:

TABLE 1000-1 REQUIREMENTS FOR CONCRETE											
Class of Concrete	Min. Comp. Strength at 28 days	Maximum Water-Cement Ratio				Consistency Max. Slump		Cement Content			
		Air-Entrained Concrete		Non Air-Entrained Concrete		Vibrated	Non-Vibrated	Vibrated		Non- Vibrated	
		Rounded Aggregate	Angular Aggregate	Rounded Aggregate	Angular Aggregate			Min.	Max.	Min.	Max.
Units	psi					inch	inch	lb/cy	lb/cy	lb/cy	lb/cy
AA	4,500	0.381	0.426	-	-	3.5	-	639	715	-	-
AA Slip Form	4,500	0.381	0.426	-	-	1.5	-	639	715	-	-
Drilled Pier	4,500	-	-	0.450	0.450	-	5-7 dry 7-9 wet	-	-	640	800
A	3,000	0.488	0.532	0.550	0.594	3.5	4	564	-	602	-
B	2,500	0.488	0.567	0.559	0.630	1.5 machine-placed 2.5 hand-placed	4	508	-	545	-
Sand Lightweight	4,500	-	0.420	-	-	4	-	715	-	-	-
Latex Modified	3,000 7 day	0.400	0.400	-	-	6	-	658	-	-	-
Flowable Fill excavatable	150 max. at 56 days	as needed	as needed	as needed	as needed	-	Flow-able	-	-	40	100
Flowable Fill non-excavatable	125	as needed	as needed	as needed	as needed	-	Flow-able	-	-	100	as needed
Pavement	4,500 design, field 650 flexural, design only	0.559	0.559	-	-	1.5 slip form 3.0 hand place	-	526	-	-	-
Precast	See Table 1077-1	as needed	as needed	-	-	6	as needed	as needed	as needed	as needed	as needed
Prestress	per contract	See Table 1078-1	See Table 1078-1	-	-	8	-	564	as needed	-	-

Page 10-6, Subarticle 1000-4(I), Use of Fly Ash, lines 36-2, replace the first paragraph with the following:

Fly ash may be substituted for cement in the mix design up to 30% at a rate of 1.0 lb of fly ash to each pound of cement replaced. Use Table 1000-1 to determine the maximum allowable water-cementitious material (cement + fly ash) ratio for the classes of concrete listed.

Page 10-7, Table 1000-3, MAXIMUM WATER-CEMENTITIOUS MATERIAL RATIO, delete the table.

Page 10-7, Article 1000-5, HIGH EARLY STRENGTH PORTLAND CEMENT CONCRETE, lines 30-31, delete the second sentence of the third paragraph.

Page 10-19, Article 1002-3, SHOTCRETE FOR TEMPORARY SUPPORT OF EXCAVATIONS, line 30, add the following at the end of Section 1002:

(H) Handling and Storing Test Panels

Notify the Area Materials Engineer when preconstruction or production test panels are made within 24 hours of shooting the panels. Field cure and protect test panels from damage in accordance with ASTM C1140 until the Department transports panels to the Materials and Tests Regional Laboratory for coring.

Page 10-23, Table 1005-1, AGGREGATE GRADATION-COARSE AGGREGATE, replace with the following:

TABLE 1005-1 AGGREGATE GRADATION - COARSE AGGREGATE													
Percentage of Total by Weight Passing													
Std. Size #	2"	1 1/2"	1"	3/4"	1/2"	3/8"	#4	#8	#10	#16	#40	#200	Remarks
4	100	90-100	20-55	0-15	-	0-5	-	-	-	-	-	A	Asphalt Plant Mix
467M	100	95-100	-	35-70	-	0-30	0-5	-	-	-	-	A	Asphalt Plant Mix
5	-	100	90-100	20-55	0-10	0-5	-	-	-	-	-	A	AST, Sediment Control Stone
57	-	100	95-100	-	25-60	-	0-10	0-5	-	-	-	A	AST, Str. Concrete, Shoulder Drain, Sediment Control Stone
57M	-	100	95-100	-	25-45	-	0-10	0-5	-	-	-	A	AST, Concrete Pavement
6M	-	-	100	90-100	20-55	0-20	0-8	-	-	-	-	A	AST
67	-	-	100	90-100	-	20-55	0-10	0-5	-	-	-	A	AST, Str. Concrete, Asphalt Plant Mix
78M	-	-	-	100	98-100	75-100	20-45	0-15	-	-	-	A	Asphalt Plant Mix, AST, Str. Conc. Weep Hole Drains
14M	-	-	-	-	-	100	35-70	5-20	-	0-8	-	A	Asphalt Plant Mix, AST, Weep Hole Drains, Str. Concrete
9	-	-	-	-	-	100	85-100	10-40	-	0-10	-	A	AST
ABC	-	100	75-97	-	55-80	-	35-55	-	25-45	-	14-30	4-12 ^B	Aggregate Base Course, Aggregate Stabilization
ABC (M)	-	100	75-100	-	45-79	-	20-40	-	0-25	-	-	0-12 ^B	Maintenance Stabilization
Light-C weight	-	-	-	-	100	80-100	5-40	0-20	-	0-10	-	0-2.5	AST

- A. See Subarticle 1005-4(A).
- B. See Subarticle 1005-4(B).
- C. For Lightweight Aggregate used in Structural Concrete, see Subarticle 1014-2(E)(6).

Page 10-39, Article 1016-3, CLASSIFICATIONS , lines 27-32, replace with the following:

Select material is clean, unweathered durable, blasted rock material obtained from an approved source. While no specific gradation is required, the below criteria will be used to evaluate the materials for visual acceptance by the Engineer:

- (A) At least 50% of the rock has a diameter of from 1.5 ft to 3 ft,
- (B) 30% of the rock ranges in size from 2” to 1.5 ft in diameter, and
- (C) Not more than 20% of the rock is less than 2” in diameter. No rippable rock will be permitted.

Page 10-40, Tables 1018-1 and 1018-2, PIEDMONT, WESTERN AND COASTAL AREA CRITERIA FOR ACCEPTANCE OF BORROW MATERIAL, under second column in both tables, replace second row with the following:

Acceptable, but not to be used in the top 3 ft of embankment or backfill

Page 10-46, Article 1024-1, PORTLAND CEMENT, line 33, add the following as the ninth paragraph:

Use Type IL blended cement that meets AASHTO M 240, except that the limestone content is limited to between 5 and 12% by weight and the constituents shall be interground. Class F fly ash can replace a portion of Type IL blended cement and shall be replaced as outlined in Subarticle 1000-4(I) for Portland cement. For mixes that contain cement with alkali content between 0.6% and 1.0% and for mixes that contain a reactive aggregate documented by the Department, use a pozzolan in the amount shown in Table 1024-1.

Page 10-46, Table 1024-1, POZZOLANS FOR USE IN PORTLAND CEMENT CONCRETE, replace with the following:

TABLE 1024-1 POZZOLANS FOR USE IN PORTLAND CEMENT CONCRETE	
Pozzolan	Rate
Class F Fly Ash	20% - 30% by weight of required cement content with 1.0 lb Class F fly ash per lb of cement replaced
Ground Granulated Blast Furnace Slag	35%-50% by weight of required cement content with 1.0 lb slag per lb of cement replaced
Microsilica	4%-8% by weight of required cement content with 1.0 lb microsilica per lb of cement replaced

Page 10-47, Subarticle 1024-3(B), Approved Sources, lines 16-18, replace the second sentence of the second paragraph with the following:

Tests shall be performed by AASHTO's designated National Transportation Product Evaluation Program (NTPEP) laboratory for concrete admixture testing.

Page 10-65, Article 1050-1, GENERAL, line 41, replace the first sentence with the following:

All fencing material and accessories shall meet Section 106.

Page 10-115, Subarticle 1074-7(B), Gray Iron Castings, lines 10-11, replace the first two sentences with the following:

Supply gray iron castings meeting all facets of AASHTO M 306 excluding proof load. Proof load testing will only be required for new casting designs during the design process, and conformance to M306 loading (40,000 lb.) will be required only when noted on the design documents.

Page 10-126, Table 1078-1, REQUIREMENTS FOR CONCRETE, replace with the following:

TABLE 1078-1 REQUIREMENTS FOR CONCRETE		
Property	28 Day Design Compressive Strength 6,000 psi or less	28 Day Design Compressive Strength greater than 6,000 psi
Maximum Water/Cementitious Material Ratio	0.45	0.40
Maximum Slump without HRWR	3.5"	3.5"
Maximum Slump with HRWR	8"	8"
Air Content (upon discharge into forms)	5 + 2%	5 + 2%

Page 10-151, Article 1080-4, INSPECTION AND SAMPLING, lines 18-22, replace (B), (C) and (D) with the following:

- (B) At least 3 panels prepared as specified in 5.5.10 of AASHTO M 300, Bullet Hole Immersion Test.
- (C) At least 3 panels of 4"x6"x1/4" for the Elcometer Adhesion Pull Off Test, ASTM D4541.
- (D) A certified test report from an approved independent testing laboratory for the Salt Fog Resistance Test, Cyclic Weathering Resistance Test, and Bullet Hole Immersion Test as specified in AASHTO M 300.
- (E) A certified test report from an approved independent testing laboratory that the product has been tested for slip coefficient and meets AASHTO M253, Class B.

Page 10-161, Subarticle 1081-1(A), Classifications, lines 29-33, delete first 3 sentences of the description for Type 2 and replace with the following:

Type 2 - A low-modulus, general-purpose adhesive used in epoxy mortar repairs. It may be used to patch spalled, cracked or broken concrete where vibration, shock or expansion and contraction are expected.

Page 10-162, Subarticle 1081-1(A), Classifications, lines 4-7, delete the second and third sentences of the description for Type 3A. **Lines 16-22**, delete Types 6A, 6B and 6C.

Page 10-162, Subarticle 1081-1(B), Requirements, lines 26-30, replace the second paragraph with the following:

For epoxy resin systems used for embedding dowel bars, threaded rods, rebar, anchor bolts and other fixtures in hardened concrete, the manufacturer shall submit test results showing that the bonding system will obtain 125% of the specified required yield strength of the fixture. Furnish certification that, for the particular bolt grade, diameter and embedment depth required, the anchor system will not fail by adhesive failure and that there is no movement of the anchor bolt. For certification and anchorage, use 3,000 psi as the minimum Portland cement concrete compressive strength used in this test. Use adhesives that meet Section 1081.

List the properties of the adhesive on the container and include density, minimum and maximum temperature application, setting time, shelf life, pot life, shear strength and compressive strength.

Page 10-163, Table 1081-1, PROPERTIES OF MIXED EPOXY RESIN SYSTEMS, replace with the following:

Property	Type 1	Type 2	Type 3	Type 3A	Type 4A	Type 4B	Type 5
Viscosity-Poises at 77°F ± 2°F	Gel	10-30	25-75	Gel	40-150	40-150	1-6
Spindle No.	-	3	4	--	4	4	2
Speed (RPM)	-	20	20	--	10	10	50
Pot Life (Minutes)	20-50	30-60	20-50	5-50	40-80	40-80	20-60
Minimum Tensile Strength at 7 days (psi)	1,500	2,000	4,000	4,000	1,500	1,500	4,000
Tensile Elongation at 7 days (%)	30 min.	30 min.	2-5	2-5	5-15	5-15	2-5
Min. Compressive Strength of 2" mortar cubes at 24 hours	3,000 (Neat)	4,000-	6,000-	6,000 (Neat)	3,000	3,000	6,000
Min. Compressive Strength of 2" mortar cubes at 7 days	5,000 (Neat)	-	-	-	-	5,000	-
Maximum Water Absorption (%)	1.5	1.0	1.0	1.5	1.0	1.0	1.0
Min. Bond Strength Slant Shear Test at 14 days (psi)	1,500	1,500	2,000	2,000	1,500	1,500	1,500

Page 10-164, Subarticle 1081-1(E), Prequalification, lines 31-33, replace the second sentence of the first paragraph with the following:

Manufacturers choosing to supply material for Department jobs must submit an application through the Value Management Unit with the following information for each type and brand name:

Page 10-164, Subarticle 1081-1(E)(3), line 37, replace with the following:

(3) Type of the material in accordance with Articles 1081-1 and 1081-4,

Page 10-165, Subarticle 1081-1(E)(6), line 1, in the first sentence of the first paragraph replace “AASHTO M 237” with “the specifications”.

Page 10-165, Subarticle 1081-1(E), Prequalification, line 9-10, delete the second sentence of the last paragraph.

Page 10-165, Subarticle 1081-1(F), Acceptance, line 14, in the first sentence of the first paragraph replace “Type 1” with “Type 3”.

Page 10-169, Subarticle 1081-3(G), Anchor Bolt Adhesives, delete this subarticle.

Page 10-170, Article 1081-3, HOT BITUMEN, line 9, add the following at the end of Section 1081:

1081-4 EPOXY RESIN ADHESIVE FOR BONDING TRAFFIC MARKINGS

(A) General

This section covers epoxy resin adhesive for bonding traffic markers to pavement surfaces.

(B) Classification

The types of epoxies and their uses are as shown below:

Type I – Rapid Setting, High Viscosity, Epoxy Adhesive. This type of adhesive provides rapid adherence to traffic markers to the surface of pavement.

Type II – Standard Setting, High Viscosity, Epoxy Adhesive. This type of adhesive is recommended for adherence of traffic markers to pavement surfaces when rapid set is not required.

Type III – Rapid Setting, Low Viscosity, Water Resistant, Epoxy Adhesive. This type of rapid setting adhesive, due to its low viscosity, is appropriate only for use with embedded traffic markers.

Type IV – Standard Set Epoxy for Blade Deflecting-Type Plowable Markers.

(C) Requirements

Epoxies shall conform to the requirements set forth in AASHTO M 237.

(D) Prequalification

Refer to Subarticle 1081-1(E).

(E) Acceptance

Refer to Subarticle 1081-1(F).

Page 10-173, Article 1084-2, STEEL SHEET PILES, lines 37-38, replace first paragraph with the following:

Steel sheet piles detailed for permanent applications shall be hot rolled and meet ASTM A572 or ASTM A690 unless otherwise required by the plans. Steel sheet piles shall be coated as required

by the plans. Galvanized sheet piles shall be coated in accordance with Section 1076. Metallized sheet piles shall be metallized in accordance to the Project Special Provision “Thermal Sprayed Coatings (Metallization)” with an 8 mil, 99.9% aluminum alloy coating and a 0.5 mil seal coating. Any portion of the metallized sheet piling encased in concrete shall receive a barrier coat. The barrier coat shall be an approved waterborne coating with a low-viscosity which readily absorbs into the pores of the aluminum thermal sprayed coating. The waterborne coating shall be applied at a spreading rate that results in a theoretical 1.5 mil dry film thickness. The manufacturer shall issue a letter of certification that the resin chemistry of the waterborne coating is compatible with the 99.9% aluminum thermal sprayed alloy and suitable for tidal water applications.

Page 10-174, Subarticle 1086-1(B)(1), Epoxy, lines 18-24, replace with the following:

The epoxy shall meet Article 1081-4.

The 2 types of epoxy adhesive which may be used are Type I, Rapid Setting, and Type II, Standard Setting. Use Type II when the pavement temperature is above 60°F or per the manufacturer’s recommendations whichever is more stringent. Use Type I when the pavement temperature is between 50°F and 60°F or per the manufacturer’s recommendations whichever is more stringent. Epoxy adhesive Type I, Cold Set, may be used to attach temporary pavement markers to the pavement surface when the pavement temperature is between 32°F and 50°F or per the manufacturer’s recommendations whichever is more stringent.

Page 10-175, Subarticle 1086-2(E), Epoxy Adhesives, line 27, replace “Section 1081” with “Article 1081-4”.

Page 10-177, Subarticle 1086-3(E), Epoxy Adhesives, line 22, replace “Section 1081” with “Article 1081-4”.

Page 10-179, Subarticle 1087-4(A), Composition, lines 39-41, replace the third paragraph with the following:

All intermixed and drop-on glass beads shall not contain more than 75 ppm arsenic or 200 ppm lead.

Page 10-180, Subarticle 1087-4(B), Physical Characteristics, line 8, replace the second paragraph with the following:

All intermixed and drop-on glass beads shall comply with NCGS § 136-30.2 and 23 USC § 109(r).

Page 10-181, Subarticle 1087-7(A), Intermixed and Drop-on Glass Beads, line 24, add the following after the first paragraph:

Use X-ray Fluorescence for the normal sampling procedure for intermixed and drop-on beads, without crushing, to check for any levels of arsenic and lead. If any arsenic or lead is detected, the sample shall be crushed and repeat the test using X-ray Fluorescence. If the X-ray Fluorescence test shows more than a LOD of 5 ppm, test the beads using United States Environmental Protection Agency Method 6010B, 6010C or 3052 for no more than 75 ppm arsenic or 200 ppm lead.

SELECT MATERIAL, CLASS III, TYPE 3:

(1-17-12)

1016, 1044

SP10 R05

Revise the *2012 Standard Specifications* as follows:

Page 10-39, Article 1016-3, CLASS III, add the following after line 14:

Type 3 Select Material

Type 3 select material is a natural or manufactured fine aggregate material meeting the following gradation requirements and as described in Sections 1005 and 1006:

Percentage of Total by Weight Passing							
3/8"	#4	#8	#16	#30	#50	#100	#200
100	95-100	65-100	35-95	15-75	5-35	0-25	0-8

Page 10-39, Article 1016-3, CLASS III, line 15, replace “either type” with “Type 1, Type 2 or Type 3”.

Page 10-62, Article 1044-1, line 36, delete the sentence and replace with the following:

Subdrain fine aggregate shall meet Class III select material, Type 1 or Type 3.

Page 10-63, Article 1044-2, line 2, delete the sentence and replace with the following:

Subdrain coarse aggregate shall meet Class V select material.

SHOULDER AND SLOPE BORROW:

(3-19-13)

1019

SP10 R10

Use soil in accordance with Section 1019 of the *2012 Standard Specifications*. Use soil consisting of loose, friable, sandy material with a PI greater than 6 and less than 25 and a pH ranging from 5.5 to 7.0.

Soil with a pH ranging from 4.0 to 5.5 will be accepted without further testing if additional limestone is provided in accordance with the application rates shown in Table 1019-1A. Soil type is identified during the soil analysis. Soils with a pH above 7.0 require acidic amendments to be added. Submit proposed acidic amendments to the Engineer for review and approval. Soils with a pH below 4.0 or that do not meet the PI requirements shall not be used.

pH TEST RESULT	Sandy Soils Additional Rate (lbs. / Acre)	Silt Loam Soils Additional Rate (lbs. / Acre)	Clay Loam Soils Additional Rate (lbs. / Acre)
4.0 - 4.4	1,000	4,000	6,000
4.5 - 4.9	500	3,000	5,000
5.0 - 5.4	NA	2,000	4,000

Note: Limestone application rates shown in this table are in addition to the standard rate of 4000 lbs. / acre required for seeding and mulching.

No direct payment will be made for providing additional lime or acidic amendments for Ph adjustment.

GROUT PRODUCTION AND DELIVERY:

(3-17-15)

1003

SP10 R20

Revise the *2012 Standard Specifications* as follows:

Replace Section 1003 with the following:

**SECTION 1003
GROUT PRODUCTION AND DELIVERY**

1003-1 DESCRIPTION

This section addresses cement grout to be used for structures, foundations, retaining walls, concrete barriers, embankments, pavements and other applications in accordance with the contract. Produce non-metallic grout composed of Portland cement and water and at the Contractor's option or as required, aggregate and pozzolans. Include chemical admixtures as required or needed. Provide sand cement or neat cement grout as required. Define "sand cement grout" as grout with only fine aggregate and "neat cement grout" as grout without aggregate.

The types of grout with their typical uses are as shown below:

Type 1 – A cement grout with only a 3-day strength requirement and a fluid consistency that is typically used for filling subsurface voids.

Type 2 – A nonshrink grout with strength, height change and flow conforming to ASTM C1107 that is typically used for foundations, ground anchors and soil nails.

Type 3 – A nonshrink grout with high early strength and freeze-thaw durability requirements that is typically used in pile blockouts, grout pockets, shear keys, dowel holes and recesses for concrete barriers and structures.

Type 4 – A neat cement grout with low strength, a fluid consistency and high fly ash content that is typically used for slab jacking.

Type 5 – A low slump, low mobility sand cement grout with minimal strength that is typically used for compaction grouting.

1003-2 MATERIALS

Refer to Division 10.

Item	Section
Chemical Admixtures	1024-3
Fine Aggregate	1014-1
Fly Ash	1024-5
Ground Granulated Blast Furnace Slag	1024-6
Portland Cement	1024-1
Silica Fume	1024-7
Water	1024-4

Do not use grout that contains soluble chlorides or more than 1% soluble sulfate. At the Contractor's option, use an approved packaged grout instead of the materials above except for water. Use packaged grouts that are on the NCDOT Approved Products List.

Use admixtures for grout that are on the NCDOT Approved Products List or other admixtures in accordance with Subarticle 1024-3(E) except do not use concrete additives or unclassified or other admixtures in Type 4 or 5 grout. Use Class F fly ash for Type 4 grout and Type II Portland cement for Type 5 grout.

Use well graded rounded aggregate with a gradation, liquid limit (LL) and plasticity index (PI) that meet Table 1003-1 for Type 5 grout. Fly ash may be substituted for a portion of the fines in the aggregate. Do not use any other pozzolans in Type 5 grout.

Gradation		Maximum Liquid Limit	Maximum Plasticity Index
Sieve Designation per AASHTO M 92	Percentage Passing (% by weight)		
3/8"	100	N/A	N/A
No. 4	70 – 95		
No. 8	50 – 90		
No. 16	30 – 80		
No. 30	25 – 70		
No. 50	20 – 50		
No. 100	15 – 40		
No. 200	10 – 30	25	10

1003-3 COMPOSITION AND DESIGN

When using an approved packaged grout, a grout mix design submittal is not required. Otherwise, submit proposed grout mix designs for each grout mix to be used in the work. Mixes for all grout shall be designed by a Certified Concrete Mix Design Technician or an Engineer licensed by the State of North Carolina. Mix proportions shall be determined by a testing laboratory approved by the Department. Base grout mix designs on laboratory trial batches that meet Table 1003-2 and this section. With permission, the

Contractor may use a quantity of chemical admixture within the range shown on the current list of approved admixtures maintained by the Materials and Tests Unit.

Submit grout mix designs in terms of saturated surface dry weights on Materials and Tests Form 312U at least 35 days before proposed use. Adjust batch proportions to compensate for surface moisture contained in the aggregates at the time of batching. Changes in the saturated surface dry mix proportions will not be permitted unless revised grout mix designs have been submitted to the Engineer and approved.

Accompany Materials and Tests Form 312U with a listing of laboratory test results of compressive strength, density and flow or slump and if applicable, aggregate gradation, durability and height change. List the compressive strength of at least three 2" cubes at the age of 3 and 28 days.

The Engineer will review the grout mix design for compliance with the contract and notify the Contractor as to its acceptability. Do not use a grout mix until written notice has been received. Acceptance of the grout mix design or use of approved packaged grouts does not relieve the Contractor of his responsibility to furnish a product that meets the contract. Upon written request from the Contractor, a grout mix design accepted and used satisfactorily on any Department project may be accepted for use on other projects.

Perform laboratory tests in accordance with the following test procedures:

Property	Test Method
Aggregate Gradation ^A	AASHTO T 27
Compressive Strength	AASHTO T 106
Density (Unit Weight)	AASHTO T 121, AASHTO T 133 ^B , ANSI/API RP ^C 13B-1 ^B (Section 4, Mud Balance)
Durability	AASHTO T 161 ^D
Flow	ASTM C939 (Flow Cone)
Height Change	ASTM C1090 ^E
Slump	AASHTO T 119

A. Applicable to grout with aggregate.

B. Applicable to Neat Cement Grout.

C. American National Standards Institute/American Petroleum Institute Recommended Practice.

D. Procedure A (Rapid Freezing and Thawing in Water) required.

E. Moist room storage required.

1003-4 GROUT REQUIREMENTS

Provide grout types in accordance with the contract. Use grouts with properties that meet Table 1003-2. The compressive strength of the grout will be considered the average compressive strength test results of three 2" cubes at each age. Make cubes that meet AASHTO T 106 from the grout delivered for the work or mixed on-site. Make cubes at

such frequencies as the Engineer may determine and cure them in accordance with AASHTO T 106.

Type of Grout	Minimum Compressive Strength at		Height Change at 28 days	Flow ^A /Slump ^B	Minimum Durability Factor
	3 days	28 days			
1	3,000 psi	–	–	10 – 30 sec	–
2	Table 1 ^C			Fluid Consistency ^C	–
3	5,000 psi	–	0 – 0.2%	Per Accepted Grout Mix Design/ Approved Packaged Grout	80
4 ^D	600 psi	1,500 psi	–	10 – 26 sec	–
5	–	500 psi	–	1 – 3"	–

A. Applicable to Type 1 through 4 grouts.

B. Applicable to Type 5 grout.

C. ASTM C1107.

D. Use Type 4 grout with proportions by volume of 1 part cement and 3 parts fly ash.

1003-5 TEMPERATURE REQUIREMENTS

When using an approved packaged grout, follow the manufacturer's instructions for grout and air temperature at the time of placement. Otherwise, the grout temperature at the time of placement shall be not less than 50°F nor more than 90°F. Do not place grout when the air temperature measured at the location of the grouting operation in the shade away from artificial heat is below 40°F.

1003-6 ELAPSED TIME FOR PLACING GROUT

Agitate grout continuously before placement. Regulate the delivery so the maximum interval between the placing of batches at the work site does not exceed 20 minutes. Place grout before exceeding the times in Table 1003-3. Measure the elapsed time as the time between adding the mixing water to the grout mix and placing the grout.

TABLE 1003-3 ELAPSED TIME FOR PLACING GROUT (with continuous agitation)		
Air or Grout Temperature, Whichever is Higher	Maximum Elapsed Time	
	No Retarding Admixture Used	Retarding Admixture Used
90°F or above	30 minutes	1 hr. 15 minutes
80°F through 89°F	45 minutes	1 hr. 30 minutes
79°F or below	60 minutes	1 hr. 45 minutes

1003-7 MIXING AND DELIVERY

Use grout free of any lumps and undispersed cement. When using an approved packaged grout, mix grout in accordance with the manufacturer's instructions. Otherwise, comply with Articles 1000-8 through 1000-12 to the extent applicable for grout instead of concrete.

GEOSYNTHETICS:

(2-16-16)

1056

SP10 R25

Revise the *2012 Standard Specifications* as follows:

Replace Section 1056 with the following:

SECTION 1056 GEOSYNTHETICS

1056-1 DESCRIPTION

Provide geosynthetics for subsurface drainage, separation, stabilization, reinforcement, erosion control, filtration and other applications in accordance with the contract. Use geotextiles, geocomposite drains and geocells that are on the NCDOT Approved Products List. Prefabricated geocomposite drains include sheet, strip and vertical drains (PVDs), i.e., "wick drains" consisting of a geotextile attached to and/or encapsulating a plastic drainage core. Geocells are comprised of ultrasonically welded polymer strips that when expanded form a 3D honeycomb grid that is typically filled with material to support vegetation.

If necessary or required, hold geotextiles and sheet drains in place with new wire staples, i.e., "sod staples" that meet Subarticle 1060-8(D) or new anchor pins. Use steel anchor pins with a diameter of at least 3/16" and a length of at least 18" and with a point at one end and a head at the other end that will retain a steel washer with an outside diameter of at least 1.5".

1056-2 HANDLING AND STORING

Load, transport, unload and store geosynthetics so geosynthetics are kept clean and free of damage. Label, ship and store geosynthetics in accordance with Section 7 of AASHTO M 288. Geosynthetics with defects, flaws, deterioration or damage will be rejected. Do not unwrap geosynthetics until just before installation. Do not leave geosynthetics exposed for more than 7 days before covering except for geosynthetics for temporary wall faces and erosion control.

1056-3 CERTIFICATIONS

Provide Type 1, Type 2 or Type 4 material certifications in accordance with Article 106-3 for geosynthetics. Define “minimum average roll value” (MARV) in accordance with ASTM D4439. Provide certifications with MARV for geosynthetic properties as required. Test geosynthetics using laboratories accredited by the Geosynthetic Accreditation Institute (GAI) to perform the required test methods. Sample geosynthetics in accordance with ASTM D4354.

1056-4 GEOTEXTILES

When required, sew geotextiles together in accordance with Article X1.1.4 of AASHTO M 288. Provide sewn seams with seam strengths meeting the required strengths for the geotextile type and class specified.

Provide geotextile types and classes in accordance with the contract. Geotextiles will be identified by the product name printed directly on the geotextile. When geotextiles are not marked with a product name or marked with only a manufacturing plant identification code, geotextiles will be identified by product labels attached to the geotextile wrapping. When identification is based on labels instead of markings, unwrap geotextiles just before use in the presence of the Engineer to confirm that the product labels on both ends of the outside of the geotextile outer wrapping match the labels affixed to both ends of the inside of the geotextile roll core. Partial geotextile rolls without the product name printed on the geotextile or product labels affixed to the geotextile roll core may not be used.

Use woven or nonwoven geotextiles with properties that meet Table 1056-1. Define “machine direction” (MD) and “cross-machine direction” (CD) in accordance with ASTM D4439.

TABLE 1056-1 GEOTEXTILE REQUIREMENTS						
Property	Requirement					Test Method
	Type 1	Type 2	Type 3 ^A	Type 4	Type 5 ^B	
<i>Typical Application</i>	<i>Shoulder Drains</i>	<i>Under Rip Rap</i>	<i>Silt Fence Fabric</i>	<i>Soil Stabilization</i>	<i>Temporary Walls</i>	
Elongation (MD & CD)	≥ 50%	≥ 50%	≤ 25%	< 50%	< 50%	ASTM D4632
Grab Strength (MD & CD)	Table 1 ^D , Class 3	Table 1 ^D , Class 1	100 lb ^C	Table 1 ^D , Class 3	–	ASTM D4632
Tear Strength (MD & CD)			–			ASTM D4533
Puncture Strength			–			ASTM D6241
Ultimate Tensile Strength (MD & CD)	–	–	–	–	2,400 lb/ft ^C (unless required otherwise in the contract)	ASTM D4595
Permittivity	Table 2 ^D , 15% to 50% <i>in Situ</i> Soil Passing 0.075 mm	Table 6 ^D , 15% to 50% <i>in Situ</i> Soil Passing 0.075mm	Table 7 ^D	Table 5 ^D	0.20 sec ⁻¹ . ^C	ASTM D4491
Apparent Opening Size					0.60 mm ^E	ASTM D4751
UV Stability (Retained Strength)					70% ^C (after 500 hr of exposure)	ASTM D4355

- A. Minimum roll width of 36" required.
 B. Minimum roll width of 13 ft required.
 C. MARV per Article 1056-3.
 D. AASHTO M 288.
 E. Maximum average roll value.

1056-5 GEOCOMPOSITE DRAINS

Provide geocomposite drain types in accordance with the contract and with properties that meet Table 1056-2.

TABLE 1056-2 GEOCOMPOSITE DRAIN REQUIREMENTS				
Property	Requirement			Test Method
	Sheet Drain	Strip Drain	Wick Drain	
Width	≥ 12" (unless required otherwise in the contract)	12" ±1/4"	4" ±1/4"	N/A
In-Plane Flow Rate ^A (with gradient of 1.0 and 24-hour seating period)	6 gpm/ft @ applied normal compressive stress of 10 psi	15 gpm/ft @ applied normal compressive stress of 7.26 psi	1.5 gpm ^B @ applied normal compressive stress of 40 psi	ASTM D4716

A. MARV per Article 1056-3.

B. Per 4" drain width.

For sheet and strip drains, use accessories (e.g., pipe outlets, connectors, fittings, etc.) recommended by the Drain Manufacturer. Provide sheet and strip drains with Type 1 geotextiles heat bonded or glued to HDPE, polypropylene or high impact polystyrene drainage cores that meet Table 1056-3.

TABLE 1056-3 DRAINAGE CORE REQUIREMENTS			
Property	Requirement (MARV)		Test Method
	Sheet Drain	Strip Drain	
Thickness	1/4"	1"	ASTM D1777 or D5199
Compressive Strength	40 psi	30 psi	ASTM D6364

For wick drains with a geotextile wrapped around a corrugated drainage core and seamed to itself, use drainage cores with an ultimate tensile strength of at least 225 lb per 4" width in accordance with ASTM D4595 and geotextiles with properties that meet Table 1056-4.

TABLE 1056-4 WICK DRAIN GEOTEXTILE REQUIREMENTS		
Property	Requirement	Test Method
Elongation	$\geq 50\%$	ASTM D4632
Grab Strength	Table 1 ^A , Class 3	ASTM D4632
Tear Strength		ASTM D4533
Puncture Strength		ASTM D6241
Permittivity	$0.7 \text{ sec}^{-1,B}$	ASTM D4491
Apparent Opening Size (AOS)	Table 2 ^A ,	ASTM D4751
UV Stability (Retained Strength)	$> 50\%$ <i>in Situ</i> Soil Passing 0.075 mm	ASTM D4355

A. AASHTO M 288.

B. MARV per Article 1056-3.

For wick drains with a geotextile fused to both faces of a corrugated drainage core along the peaks of the corrugations, use wick drains with an ultimate tensile strength of at least 1,650 lb/ft in accordance with ASTM D4595 and geotextiles with a permittivity, AOS and UV stability that meet Table 1056-4.

1056-6 GEOCELLS

Geocells will be identified by product labels attached to the geocell wrapping. Unwrap geocells just before use in the presence of the Engineer. Previously opened geocell products will be rejected.

Manufacture geocells from virgin polyethylene resin with no more than 10% rework, also called “regrind”, materials. Use geocells made from textured and perforated HDPE strips with an open area of 10% to 20% and properties that meet Table 1056-5.

TABLE 1056-5 GEOCELL REQUIREMENTS		
Property	Minimum Requirement	Test Method
Cell Depth	4"	N/A
Sheet Thickness	50 mil -5%, +10%	ASTM D5199
Density	58.4 lb/cf	ASTM D1505
Carbon Black Content	1.5%	ASTM D1603 or D4218
ESCR ^A	5000 hr	ASTM D1693
Coefficient of Direct Sliding (with material that meets AASHTO M 145 for soil classification A-2)	0.85	ASTM D5321
Short-Term Seam (Peel) Strength (for 4" seam)	320 lb	USACE ^C Technical Report GL-86-19, Appendix A
Long-Term Seam (Hang) Strength ^B (for 4" seam)	160 lb	

A. Environmental Stress Crack Resistance.

B. Minimum test period of 168 hr with a temperature change from 74°F to 130°F in 1-hour cycles.

C. US Army Corps of Engineers.

Provide geocell accessories (e.g., stakes, pins, clips, staples, rings, tendons, anchors, deadmen, etc.) recommended by the Geocell Manufacturer.

TRUCK MOUNTED CHANGEABLE MESSAGE SIGNS:

(8-21-12)

1101.02

SP11 R10

Revise the *2012 Roadway Standard Drawings* as follows:

Drawing No. 1101.02, Sheet 12, TEMPORARY LANE CLOSURES, replace General Note #11 with the following:

11- TRUCK MOUNTED CHANGEABLE MESSAGE SIGNS (TMCMS) USED ON SHADOW VEHICLES FOR "IN LANE" ACTIVITIES SHALL BE A MINIMUM OF 43" X 73". THE DISPLAY PANEL SHALL HAVE FULL MATRIX CAPABILITY WITH THE CAPABILITY TO PROVIDE 2 MESSAGE LINES WITH 7 CHARACTERS PER LINE WITH A MINIMUM CHARACTER HEIGHT OF 18". FOR ADDITIONAL MESSAGING, CONTACT THE WORK ZONE TRAFFIC CONTROL SECTION.

12- TMCMS USED FOR ADVANCED WARNING ON VEHICLES LOCATED ON THE SHOULDER MAY BE SMALLER THAN 43" X 73". THE DISPLAY PANEL SHALL HAVE THE CAPABILITY TO PROVIDE 2 MESSAGE LINES WITH 7 CHARACTERS PER LINE WITH A MINIMUM CHARACTER HEIGHT OF 18". FOR ADDITIONAL MESSAGING, CONTACT THE WORK ZONE TRAFFIC CONTROL SECTION.

Drawing No. 1101.02, Sheet 13, TEMPORARY LANE CLOSURES, replace General Note #12 with the following:

12- TRUCK MOUNTED CHANGEABLE MESSAGE SIGNS (TMCMS) USED ON SHADOW VEHICLES FOR "IN LANE" ACTIVITIES SHALL BE A MINIMUM OF 43" X 73". THE DISPLAY PANEL SHALL HAVE FULL MATRIX CAPABILITY WITH THE CAPABILITY TO PROVIDE 2 MESSAGE LINES WITH 7 CHARACTERS PER LINE WITH A MINIMUM CHARACTER HEIGHT OF 18". FOR ADDITIONAL MESSAGING, CONTACT THE WORK ZONE TRAFFIC CONTROL SECTION.

13- TMCMS USED FOR ADVANCED WARNING ON VEHICLES LOCATED ON THE SHOULDER MAY BE SMALLER THAN 43" X 73". THE DISPLAY PANEL SHALL HAVE THE CAPABILITY TO PROVIDE 2 MESSAGE LINES WITH 7 CHARACTERS PER LINE WITH A MINIMUM CHARACTER HEIGHT OF 18". FOR ADDITIONAL MESSAGING, CONTACT THE WORK ZONE TRAFFIC CONTROL SECTION.

GROUT REFERENCES FOR UTILITY MANHOLES:

(8-18-15)

1525

SP15 R40

Revise the *2012 Standard Specifications* as follows:

Page 15-13, Article 1525-2, Materials, line 9, in the materials table, add the following:

Item	Section
Grout, Type 2	1003

Page 15-13, Article 1525-2, Materials, lines 20-21, replace the third paragraph after the materials table with the following:

Use Type 2 grout with properties that meet Table 1003-2 in the *Grout Production and Delivery* provision except provide grout with a plastic consistency in accordance with ASTM C1107.

Page 15-14, Subarticle 1525-3(B), Installation of Precast Units, line 22, in the second sentence of the first paragraph, replace "non-shrink grout." with "grout."

PERMANENT SEEDING AND MULCHING:

(7-1-95)

1660

SP16 R02

The Department desires that permanent seeding and mulching be established on this project as soon as practical after slopes or portions of slopes have been graded. As an incentive to obtain an early stand of vegetation on this project, the Contractor's attention is called to the following:

For all permanent seeding and mulching that is satisfactorily completed in accordance with the requirements of Section 1660 in the *2012 Standard Specifications* and within the following percentages of elapsed contract times, an additional payment will be made to the Contractor as an incentive additive. The incentive additive will be determined by multiplying the number of acres of seeding and mulching satisfactorily completed times the contract unit bid price per acre for Seeding and Mulching times the appropriate percentage additive.

Percentage of Elapsed Contract Time	Percentage Additive
0% - 30%	30%
30.01% - 50%	15%

Percentage of elapsed contract time is defined as the number of calendar days from the date of availability of the contract to the date the permanent seeding and mulching is acceptably completed divided by the total original contract time.

STANDARD SPECIAL PROVISION
AVAILABILITY OF FUNDS – TERMINATION OF CONTRACTS

(5-20-08)

Z-2

General Statute 143C-6-11. (h) Highway Appropriation is hereby incorporated verbatim in this contract as follows:

(h) Amounts Encumbered. – Transportation project appropriations may be encumbered in the amount of allotments made to the Department of Transportation by the Director for the estimated payments for transportation project contract work to be performed in the appropriation fiscal year. The allotments shall be multiyear allotments and shall be based on estimated revenues and shall be subject to the maximum contract authority contained in *General Statute 143C-6-11(c)*. Payment for transportation project work performed pursuant to contract in any fiscal year other than the current fiscal year is subject to appropriations by the General Assembly. Transportation project contracts shall contain a schedule of estimated completion progress, and any acceleration of this progress shall be subject to the approval of the Department of Transportation provided funds are available. The State reserves the right to terminate or suspend any transportation project contract, and any transportation project contract shall be so terminated or suspended if funds will not be available for payment of the work to be performed during that fiscal year pursuant to the contract. In the event of termination of any contract, the contractor shall be given a written notice of termination at least 60 days before completion of scheduled work for which funds are available. In the event of termination, the contractor shall be paid for the work already performed in accordance with the contract specifications.

Payment will be made on any contract terminated pursuant to the special provision in accordance with Subarticle 108-13(E) of the *2012 Standard Specifications*.

STANDARD SPECIAL PROVISION
NCDOT GENERAL SEED SPECIFICATION FOR SEED QUALITY

(5-17-11)

Z-3

Seed shall be sampled and tested by the North Carolina Department of Agriculture and Consumer Services, Seed Testing Laboratory. When said samples are collected, the vendor shall supply an independent laboratory report for each lot to be tested. Results from seed so sampled shall be final. Seed not meeting the specifications shall be rejected by the Department of Transportation and shall not be delivered to North Carolina Department of Transportation warehouses. If seed has been delivered it shall be available for pickup and replacement at the supplier's expense.

Any re-labeling required by the North Carolina Department of Agriculture and Consumer Services, Seed Testing Laboratory, that would cause the label to reflect as otherwise specified herein shall be rejected by the North Carolina Department of Transportation.

Seed shall be free from seeds of the noxious weeds Johnsongrass, Balloonvine, Jimsonweed, Witchweed, Itchgrass, Serrated Tussock, Showy Crotalaria, Smooth Crotalaria, Sicklepod, Sandbur, Wild Onion, and Wild Garlic. Seed shall not be labeled with the above weed species on the seed analysis label. Tolerances as applied by the Association of Official Seed Analysts will NOT be allowed for the above noxious weeds except for Wild Onion and Wild Garlic.

Tolerances established by the Association of Official Seed Analysts will generally be recognized. However, for the purpose of figuring pure live seed, the found pure seed and found germination percentages as reported by the North Carolina Department of Agriculture and Consumer Services, Seed Testing Laboratory will be used. Allowances, as established by the NCDOT, will be recognized for minimum pure live seed as listed on the following pages.

The specifications for restricted noxious weed seed refers to the number per pound as follows:

<u>Restricted Noxious Weed</u>	<u>Limitations per Lb. Of Seed</u>	<u>Restricted Noxious Weed</u>	<u>Limitations per Lb. of Seed</u>
Blessed Thistle	4 seeds	Cornflower (Ragged Robin)	27 seeds
Cocklebur	4 seeds	Texas Panicum	27 seeds
Spurred Anoda	4 seeds	Bracted Plantain	54 seeds
Velvetleaf	4 seeds	Buckhorn Plantain	54 seeds
Morning-glory	8 seeds	Broadleaf Dock	54 seeds
Corn Cockle	10 seeds	Curly Dock	54 seeds
Wild Radish	12 seeds	Dodder	54 seeds
Purple Nutsedge	27 seeds	Giant Foxtail	54 seeds
Yellow Nutsedge	27 seeds	Horsenettle	54 seeds
Canada Thistle	27 seeds	Quackgrass	54 seeds
Field Bindweed	27 seeds	Wild Mustard	54 seeds
Hedge Bindweed	27 seeds		

Seed of Pensacola Bahiagrass shall not contain more than 7% inert matter, Kentucky Bluegrass, Centipede and Fine or Hard Fescue shall not contain more than 5% inert matter whereas a maximum of 2% inert matter will be allowed on all other kinds of seed. In addition, all seed shall not contain more than 2% other crop seed nor more than 1% total weed seed. The germination rate as tested by the North Carolina Department of Agriculture shall not fall below 70%, which includes both dormant and hard seed. Seed shall be labeled with not more than 7%, 5% or 2% inert matter (according to above specifications), 2% other crop seed and 1% total weed seed.

Exceptions may be made for minimum pure live seed allowances when cases of seed variety shortages are verified. Pure live seed percentages will be applied in a verified shortage situation. Those purchase orders of deficient seed lots will be credited with the percentage that the seed is deficient.

FURTHER SPECIFICATIONS FOR EACH SEED GROUP ARE GIVEN BELOW:

Minimum 85% pure live seed; maximum 1% total weed seed; maximum 2% total other crop seed; maximum 144 restricted noxious weed seed per pound. Seed less than 83% pure live seed will not be approved.

Sericea Lespedeza
Oats (seeds)

Minimum 80% pure live seed; maximum 1% total weed seed; maximum 2% total other crop; maximum 144 restricted noxious weed seed per pound. Seed less than 78% pure live seed will not be approved.

Tall Fescue (all approved varieties)	Bermudagrass
Kobe Lespedeza	Browntop Millet
Korean Lespedeza	German Millet – Strain R
Weeping Lovegrass	Clover – Red/White/Crimson
Carpetgrass	

Minimum 78% pure live seed; maximum 1% total weed seed; maximum 2% total other crop seed; maximum 144 restricted noxious weed seed per pound. Seed less than 76% pure live seed will not be approved.

Common or Sweet Sundangrass

Minimum 76% pure live seed; maximum 1% total weed seed; maximum 2% total other crop seed; maximum 144 restricted noxious weed seed per pound. Seed less than 74% pure live seed will not be approved.

Rye (grain; all varieties)
Kentucky Bluegrass (all approved varieties)
Hard Fescue (all approved varieties)
Shrub (bicolor) Lespedeza

Minimum 70% pure live seed; maximum 1% total weed seed; maximum 2% total other crop seed; maximum 144 noxious weed seed per pound. Seed less than 70% pure live seed will not be approved.

Centipedegrass
Crownvetch
Pensacola Bahiagrass
Creeping Red Fescue

Japanese Millet
Reed Canary Grass
Zoysia

Minimum 70% pure live seed; maximum 1% total weed seed; maximum 2% total other crop seed; maximum 5% inert matter; maximum 144 restricted noxious weed seed per pound.

Barnyard Grass
Big Bluestem
Little Bluestem
Bristly Locust
Birdsfoot Trefoil
Indiangrass
Orchardgrass
Switchgrass
Yellow Blossom Sweet Clover

STANDARD SPECIAL PROVISION**ERRATA**

(1-17-12) (Rev. 04-21-15)

Z-4

Revise the 2012 *Standard Specifications* as follows:

Division 2

Page 2-7, line 31, Article 215-2 Construction Methods, replace “Article 107-26” with “Article 107-25”.

Page 2-17, Article 226-3, Measurement and Payment, line 2, delete “pipe culverts,”.

Page 2-20, Subarticle 230-4(B), Contractor Furnished Sources, change references as follows: **Line 1**, replace “(4) Buffer Zone” with “(c) Buffer Zone”; **Line 12**, replace “(5) Evaluation for Potential Wetlands and Endangered Species” with “(d) Evaluation for Potential Wetlands and Endangered Species”; and **Line 33**, replace “(6) Approval” with “(4) Approval”.

Division 3

Page 3-1, after line 15, Article 300-2 Materials, replace “1032-9(F)” with “1032-6(F)”.

Division 4

Page 4-77, line 27, Subarticle 452-3(C) Concrete Coping, replace “sheet pile” with “reinforcement”.

Division 6

Page 6-7, line 31, Article 609-3 Field Verification of Mixture and Job Mix Formula Adjustments, replace “30” with “45”.

Page 6-10, line 42, Subarticle 609-6(C)(2), replace “Subarticle 609-6(E)” with “Subarticle 609-6(D)”.

Page 6-11, Table 609-1 Control Limits, replace “Max. Spec. Limit” for the Target Source of $P_{0.075}/P_{be}$ Ratio with “1.0”.

Page 6-40, Article 650-2 Materials, replace “Subarticle 1012-1(F)” with “Subarticle 1012-1(E)”

Division 7

Page 7-1, Article 700-3, CONCRETE HAULING EQUIPMENT, line 33, replace “competition” with “completion”.

Division 8

Page 8-23, line 10, Article 838-2 Materials, replace “Portland Cement Concrete, Class B” with “Portland Cement Concrete, Class A”.

Division 10

Page 10-166, Article 1081-3 Hot Bitumen, replace “Table 1081-16” with “Table 1081-2”, replace “Table 1081-17” with “Table 1081-3”, and replace “Table 1081-18” with “Table 1081-4”.

Division 12

Page 12-7, Table 1205-3, add “FOR THERMOPLASTIC” to the end of the title.

Page 12-8, Subarticle 1205-5(B), line 13, replace “Table 1205-2” with “Table 1205-4”.

Page 12-8, Table 1205-4 and 1205-5, replace “THERMOPLASTIC” in the title of these tables with “POLYUREA”.

Page 12-9, Subarticle 1205-6(B), line 21, replace “Table 1205-4” with “Table 1205-6”.

Page 12-11, Subarticle 1205-8(C), line 25, replace “Table 1205-5” with “Table 1205-7”.

Division 15

Page 15-4, Subarticle 1505-3(F) Backfilling, line 26, replace “Subarticle 235-4(C)” with “Subarticle 235-3(C)”.

Page 15-6, Subarticle 1510-3(B), after line 21, replace the allowable leakage formula with the following: $W=LD\sqrt{P} \div 148,000$

Page 15-6, Subarticle 1510-3(B), line 32, delete “may be performed concurrently or” and replace with “shall be performed”.

Page 15-17, Subarticle 1540-3(E), line 27, delete “Type 1”.

Division 17

Page 17-26, line 42, Subarticle 1731-3(D) Termination and Splicing within Interconnect Center, delete this subarticle.

Revise the *2012 Roadway Standard Drawings* as follows:

1633.01 Sheet 1 of 1, English Standard Drawing for Matting Installation, replace “1633.01” with “1631.01”.

STANDARD SPECIAL PROVISION**PLANT AND PEST QUARANTINES****(Imported Fire Ant, Gypsy Moth, Witchweed, And Other Noxious Weeds)**

(3-18-03) (Rev. 10-15-13)

Z-04a

Within Quarantined Area

This project may be within a county regulated for plant and/or pests. If the project or any part of the Contractor's operations is located within a quarantined area, thoroughly clean all equipment prior to moving out of the quarantined area. Comply with federal/state regulations by obtaining a certificate or limited permit for any regulated article moving from the quarantined area.

Originating in a Quarantined County

Obtain a certificate or limited permit issued by the N.C. Department of Agriculture/United States Department of Agriculture. Have the certificate or limited permit accompany the article when it arrives at the project site.

Contact

Contact the N.C. Department of Agriculture/United States Department of Agriculture at 1-800-206-9333, 919-733-6932, or <http://www.ncagr.gov/plantind/> to determine those specific project sites located in the quarantined area or for any regulated article used on this project originating in a quarantined county.

Regulated Articles Include

1. Soil, sand, gravel, compost, peat, humus, muck, and decomposed manure, separately or with other articles. This includes movement of articles listed above that may be associated with cut/waste, ditch pulling, and shoulder cutting.
2. Plants with roots including grass sod.
3. Plant crowns and roots.
4. Bulbs, corms, rhizomes, and tubers of ornamental plants.
5. Hay, straw, fodder, and plant litter of any kind.
6. Clearing and grubbing debris.
7. Used agricultural cultivating and harvesting equipment.
8. Used earth-moving equipment.
9. Any other products, articles, or means of conveyance, of any character, if determined by an inspector to present a hazard of spreading imported fire ant, gypsy moth, witchweed or other noxious weeds.

STANDARD SPECIAL PROVISION

MINIMUM WAGES

(7-21-09)

Z-5

FEDERAL: The Fair Labor Standards Act provides that with certain exceptions every employer shall pay wages at the rate of not less than SEVEN DOLLARS AND TWENTY FIVE CENTS (\$7.25) per hour.

STATE: The North Carolina Minimum Wage Act provides that every employer shall pay to each of his employees, wages at a rate of not less than SEVEN DOLLARS AND TWENTY FIVE CENTS (\$7.25) per hour.

The minimum wage paid to all skilled labor employed on this contract shall be SEVEN DOLLARS AND TWENTY FIVE CENTS (\$7.25) per hour.

The minimum wage paid to all intermediate labor employed on this contract shall be SEVEN DOLLARS AND TWENTY FIVE CENTS (\$7.25) per hour.

The minimum wage paid to all unskilled labor on this contract shall be SEVEN DOLLARS AND TWENTY FIVE CENTS (\$7.25) per hour.

This determination of the intent of the application of this act to the contract on this project is the responsibility of the Contractor.

The Contractor shall have no claim against the Department of Transportation for any changes in the minimum wage laws, Federal or State. It is the responsibility of the Contractor to keep fully informed of all Federal and State Laws affecting his contract.

STANDARD SPECIAL PROVISION**AWARD OF CONTRACT**

(6-28-77)(Rev 2/16/2016)

Z-6

“The North Carolina Department of Transportation, in accordance with the provisions of *Title VI of the Civil Rights Act of 1964* (78 Stat. 252) and the Regulations of the Department of Transportation (*49 C.F.R., Part 21*), issued pursuant to such act, hereby notifies all bidders that it will affirmatively insure that the contract entered into pursuant to this advertisement will be awarded to the lowest responsible bidder without discrimination on the ground of race, color, or national origin”.

TITLE VI AND NONDISCRIMINATION**I. Title VI Assurance**

During the performance of this contract, the contractor, for itself, its assignees and successors in interest (hereinafter referred to as the "contractor") agrees as follows:

(1) Compliance with Regulations: The contractor shall comply with the Regulation relative to nondiscrimination in Federally-assisted programs of the Department of Transportation (hereinafter, "DOT") Title 49, Code of Federal Regulations, Part 21, as they may be amended from time to time, (hereinafter referred to as the Regulations), which are herein incorporated by reference and made a part of this contract.

(2) Nondiscrimination: The Contractor, with regard to the work performed by it during the contract, shall not discriminate on the grounds of race, color, or national origin in the selection and retention of subcontractors, including procurements of materials and leases of equipment. The contractor shall not participate either directly or indirectly in the discrimination prohibited by section 21.5 of the Regulations, including employment practices when the contract covers a program set forth in Appendix B of the Regulations.

(3) Solicitations for Subcontractors, Including Procurements of Materials and Equipment: In all solicitations either by competitive bidding or negotiation made by the contractor for work to be performed under a subcontract, including procurements of materials or leases of equipment, each potential subcontractor or supplier shall be notified by the contractor of the contractor's obligations under this contract and the Regulations relative to nondiscrimination on the grounds of race, color, or national origin.

(4) Information and Reports: The contractor shall provide all information and reports required by the Regulations or directives issued pursuant thereto, and shall permit access to its books, records, accounts, other sources of information, and its facilities as may be determined by the North Carolina Department of Transportation (NCDOT) or the Federal Highway Administration (FHWA) to be pertinent to ascertain compliance with such Regulations, orders and instructions. Where any information required of a contractor is in the exclusive possession of another who fails or refuses to furnish this information the contractor shall so certify to the NCDOT, or the FHWA as appropriate, and shall set forth what efforts it has made to obtain the information.

(5) Sanctions for Noncompliance: In the event of the contractor's noncompliance with the nondiscrimination provisions of this contract, the NCDOT shall impose such contract sanctions as it or the FHWA may determine to be appropriate, including, but not limited to:

- (a) Withholding of payments to the contractor under the contract until the contractor complies, and/or
- (b) Cancellation, termination or suspension of the contract, in whole or in part.

(6) Incorporation of Provisions: The contractor shall include the provisions of paragraphs (1) through (6) in every subcontract, including procurements of materials and leases of equipment, unless exempt by the Regulations, or directives issued pursuant thereto.

The contractor shall take such action with respect to any subcontractor procurement as the NCDOT or the FHWA may direct as a means of enforcing such provisions including sanctions for noncompliance: provided, however, that, in the event a contractor becomes involved in, or is threatened with, litigation with a subcontractor or supplier as a result of such direction, the contractor may request the NCDOT to enter into such litigation to protect the interests of the NCDOT, and, in addition, the contractor may request the United States to enter into such litigation to protect the interests of the United States.

II. Title VI Nondiscrimination Program

Title VI of the 1964 Civil Rights Act, 42 U.S.C. 2000d, provides that: "No person in the United States shall, on the grounds of race, color, or national origin, be excluded from participation in, be denied the benefits of, or be subjected to discrimination under any program or activity receiving Federal financial assistance." The broader application of nondiscrimination law is found in other statutes, executive orders, and regulations (see Section III, Pertinent Nondiscrimination Authorities), which provide additional protections based on age, sex, disability and religion. In addition, the 1987 Civil Rights Restoration Act extends nondiscrimination coverage to all programs and activities of federal-aid recipients and contractors, including those that are not federally-funded.

Nondiscrimination Assurance

The North Carolina Department of Transportation (NCDOT) hereby gives assurance that no person shall on the ground of race, color, national origin, sex, age, and disability, be excluded from participation in, be denied the benefits of, or be otherwise subjected to discrimination under any program or activity conducted by the recipient, as provided by Title VI of the Civil Rights Act of 1964, the Civil Rights Restoration Act of 1987, and any other related Civil Rights authorities, whether those programs and activities are federally funded or not.

Obligation

During the performance of this contract, the Contractor and its subcontractors are responsible for complying with NCDOT's Title VI Program. The Contractor must ensure that NCDOT's Notice of Nondiscrimination is posted in conspicuous locations accessible to all employees and subcontractors on the jobsite, along with the Contractor's own Equal Employment Opportunity (EEO) Policy Statement. The Contractor shall physically incorporate this "**TITLE VI AND NONDISCRIMINATION**" language, in its entirety, into all its subcontracts on federally-assisted and state-funded NCDOT-owned projects, and ensure its inclusion by subcontractors into all subsequent lower tier subcontracts. The Contractor and its subcontractors shall also physically incorporate the **FHWA-1273**, in its entirety, into all subcontracts and subsequent lower tier subcontracts on Federal-aid highway construction contracts only. The Contractor is

also responsible for making its subcontractors aware of NCDOT's Discrimination Complaints Process, as follows:

FILING OF COMPLAINTS

1. **Applicability** – These complaint procedures apply to the beneficiaries of the NCDOT's programs, activities, and services, including, but not limited to, members of the public, contractors, subcontractors, consultants, and other sub-recipients of federal and state funds.
2. **Eligibility** – Any person or class of persons who believes he/she has been subjected to discrimination or retaliation prohibited by any of the Civil Rights authorities, based upon race, color, sex, age, national origin, or disability, may file a written complaint with NCDOT's Civil Rights office. The law prohibits intimidation or retaliation of any sort. The complaint may be filed by the affected individual or a representative, and must be in writing.
3. **Time Limits and Filing Options** – A complaint must be filed no later than 180 calendar days after the following:
 - The date of the alleged act of discrimination; or
 - The date when the person(s) became aware of the alleged discrimination; or
 - Where there has been a continuing course of conduct, the date on which that conduct was discontinued or the latest instance of the conduct.

Title VI and other discrimination complaints may be submitted to the following entities:

- **North Carolina Department of Transportation**, Office of Equal Opportunity & Workforce Services (EOWS), External Civil Rights Section, 1511 Mail Service Center, Raleigh, NC 27699-1511; 919-508-1808 or toll free 800-522-0453
- **US Department of Transportation**, Departmental Office of Civil Rights, External Civil Rights Programs Division, 1200 New Jersey Avenue, SE, Washington, DC 20590; 202-366-4070
 - Federal Highway Administration**, North Carolina Division Office, 310 New Bern Avenue, Suite 410, Raleigh, NC 27601, 919-747-7010
 - Federal Highway Administration**, Office of Civil Rights, 1200 New Jersey Avenue, SE, 8th Floor, E81-314, Washington, DC 20590, 202-366-0693 / 366-0752
 - Federal Transit Administration**, Office of Civil Rights, ATTN: Title VI Program Coordinator, East Bldg. 5th Floor – TCR, 1200 New Jersey Avenue, SE, Washington, DC 20590
 - Federal Aviation Administration**, Office of Civil Rights, 800 Independence Avenue, SW, Washington, DC 20591, 202-267-3258
- **US Department of Justice**, Special Litigation Section, Civil Rights Division, 950 Pennsylvania Avenue, NW, Washington, DC 20530, 202-514-6255 or toll free 877-218-5228

4. **Format for Complaints** – Complaints must be in **writing** and **signed** by the complainant(s) or a representative and include the complainant's name, address, and telephone number. Complaints received by fax or e-mail will be acknowledged and processed. Allegations received by telephone will be reduced to writing and provided to the complainant for confirmation or revision before processing. Complaints will be accepted in other languages including Braille.

5. **Discrimination Complaint Form** – Contact NCDOT EOWS at the phone number above to receive a full copy of the Discrimination Complaint Form and procedures.
6. **Complaint Basis** – Allegations must be based on issues involving race, color, national origin, sex, age, or disability. The term “basis” refers to the complainant’s membership in a protected group category. Contact this office to receive a Discrimination Complaint Form.

Protected Categories	Definition	Examples	Applicable Statutes and Regulations	
			FHWA	FTA
Race	An individual belonging to one of the accepted racial groups; or the perception, based usually on physical characteristics that a person is a member of a racial group	Black/African American, Hispanic/Latino, Asian, American Indian/Alaska Native, Native Hawaiian/Pacific Islander, White	Title VI of the Civil Rights Act of 1964; 49 CFR Part 21; 23 CFR 200	Title VI of the Civil Rights Act of 1964; 49 CFR Part 21; Circular 4702.1B
Color	Color of skin, including shade of skin within a racial group	Black, White, brown, yellow, etc.		
National Origin	Place of birth. Citizenship is not a factor. Discrimination based on language or a person’s accent is also covered.	Mexican, Cuban, Japanese, Vietnamese, Chinese		
Sex	Gender	Women and Men	1973 Federal-Aid Highway Act	Title IX of the Education Amendments of 1972
Age	Persons of any age	21 year old person	Age Discrimination Act of 1975	
Disability	Physical or mental impairment, permanent or temporary, or perceived.	Blind, alcoholic, paraplegic, epileptic, diabetic, arthritic	Section 504 of the Rehabilitation Act of 1973; Americans with Disabilities Act of 1990	

III. Pertinent Nondiscrimination Authorities

During the performance of this contract, the contractor, for itself, its assignees, and successors in interest agrees to comply with the following non-discrimination statutes and authorities, including, but not limited to:

- Title VI of the Civil Rights Act of 1964 (42 U.S.C. § 2000d *et seq.*, 78 stat. 252), (prohibits discrimination on the basis of race, color, national origin); and 49 CFR Part 21.
- The Uniform Relocation Assistance and Real Property Acquisition Policies Act of 1970, (42 U.S.C. § 4601), (prohibits unfair treatment of persons displaced or whose property has been acquired because of Federal or Federal-aid programs and projects);
- Federal-Aid Highway Act of 1973, (23 U.S.C. § 324 *et seq.*), (prohibits discrimination on the basis of sex);

- Section 504 of the Rehabilitation Act of 1973, (29 U.S.C. § 794 *et seq.*), as amended, (prohibits discrimination on the basis of disability); and 49 CFR Part 27;
- The Age Discrimination Act of 1975, as amended, (42 U.S.C. § 6101 *et seq.*), (prohibits discrimination on the basis of age);
- Airport and Airway Improvement Act of 1982, (49 USC § 471, Section 47123), as amended, (prohibits discrimination based on race, creed, color, national origin, or sex);
- The Civil Rights Restoration Act of 1987, (PL 100-209), (Broadened the scope, coverage and applicability of Title VI of the Civil Rights Act of 1964, The Age Discrimination Act of 1975 and Section 504 of the Rehabilitation Act of 1973, by expanding the definition of the terms “programs or activities” to include all of the programs or activities of the Federal-aid recipients, sub-recipients and contractors, whether such programs or activities are Federally funded or not);
- Titles II and III of the Americans with Disabilities Act, which prohibit discrimination on the basis of disability in the operation of public entities, public and private transportation systems, places of public accommodation, and certain testing entities (42 U.S.C. §§ 12131 – 12189) as implemented by Department of Transportation regulations at 49 C.F.R. parts 37 and 38;
- The Federal Aviation Administration’s Non-discrimination statute (49 U.S.C. § 47123) (prohibits discrimination on the basis of race, color, national origin, and sex);
- Executive Order 12898, Federal Actions to Address Environmental Justice in Minority Populations and Low-Income Populations, which ensures discrimination against minority populations by discouraging programs, policies, and activities with disproportionately high and adverse human health or environmental effects on minority and low-income populations;
- Executive Order 13166, Improving Access to Services for Persons with Limited English Proficiency, and resulting agency guidance, national origin discrimination includes discrimination because of limited English proficiency (LEP). To ensure compliance with Title VI, you must take reasonable steps to ensure that LEP persons have meaningful access to your programs (70 Fed. Reg. at 74087 to 74100);
- Title IX of the Education Amendments of 1972, as amended, which prohibits you from discriminating because of sex in education programs or activities (20 U.S.C. 1681 *et seq.*).
- Title VII of the Civil Rights Act of 1964 (42 U.S.C. § 2000e *et seq.*, Pub. L. 88-352), (prohibits employment discrimination on the basis of race, color, religion, sex, or national origin);
- 49 CFR Part 26, regulation to ensure nondiscrimination in the award and administration of DOT-assisted contracts in the Department's highway, transit, and airport financial assistance programs, as regards the use of Disadvantaged Business Enterprises (DBEs);
- Form FHWA-1273, “Required Contract Provisions,” a collection of contract provisions and proposal notices that are generally applicable to *all Federal-aid construction projects* and must be made a part of, and physically incorporated into, *all federally-assisted contracts*, as well as appropriate subcontracts and purchase orders, particularly Sections II (Nondiscrimination) and III (Nonsegregated Facilities).

STANDARD SPECIAL PROVISION**ON-THE-JOB TRAINING**

(10-16-07) (Rev. 4-21-15)

Z-10

Description

The North Carolina Department of Transportation will administer a custom version of the Federal On-the-Job Training (OJT) Program, commonly referred to as the Alternate OJT Program. All contractors (existing and newcomers) will be automatically placed in the Alternate Program. Standard OJT requirements typically associated with individual projects will no longer be applied at the project level. Instead, these requirements will be applicable on an annual basis for each contractor administered by the OJT Program Manager.

On the Job Training shall meet the requirements of 23 CFR 230.107 (b), 23 USC – Section 140, this provision and the On-the-Job Training Program Manual.

The Alternate OJT Program will allow a contractor to train employees on Federal, State and privately funded projects located in North Carolina. However, priority shall be given to training employees on NCDOT Federal-Aid funded projects.

Minorities and Women

Developing, training and upgrading of minorities and women toward journeyman level status is a primary objective of this special training provision. Accordingly, the Contractor shall make every effort to enroll minority and women as trainees to the extent that such persons are available within a reasonable area of recruitment. This training commitment is not intended, and shall not be used, to discriminate against any applicant for training, whether a member of a minority group or not.

Assigning Training Goals

The Department, through the OJT Program Manager, will assign training goals for a calendar year based on the contractors' past three years' activity and the contractors' anticipated upcoming year's activity with the Department. At the beginning of each year, all contractors eligible will be contacted by the Department to determine the number of trainees that will be assigned for the upcoming calendar year. At that time the Contractor shall enter into an agreement with the Department to provide a self-imposed on-the-job training program for the calendar year. This agreement will include a specific number of annual training goals agreed to by both parties. The number of training assignments may range from 1 to 15 per contractor per calendar year. The Contractor shall sign an agreement to fulfill their annual goal for the year.\

Training Classifications

The Contractor shall provide on-the-job training aimed at developing full journeyman level workers in the construction craft/operator positions. Preference shall be given to providing training in the following skilled work classifications:

Equipment Operators	Office Engineers
Truck Drivers	Estimators
Carpenters	Iron / Reinforcing Steel Workers
Concrete Finishers	Mechanics
Pipe Layers	Welders

The Department has established common training classifications and their respective training requirements that may be used by the contractors. However, the classifications established are not all-inclusive. Where the training is oriented toward construction applications, training will be allowed in lower-level management positions such as office engineers and estimators. Contractors shall submit new classifications for specific job functions that their employees are performing. The Department will review and recommend for acceptance to FHWA the new classifications proposed by contractors, if applicable. New classifications shall meet the following requirements:

Proposed training classifications are reasonable and realistic based on the job skill classification needs, and

The number of training hours specified in the training classification is consistent with common practices and provides enough time for the trainee to obtain journeyman level status.

The Contractor may allow trainees to be trained by a subcontractor provided that the Contractor retains primary responsibility for meeting the training and this provision is made applicable to the subcontract. However, only the Contractor will receive credit towards the annual goal for the trainee.

Where feasible, 25 percent of apprentices or trainees in each occupation shall be in their first year of apprenticeship or training. The number of trainees shall be distributed among the work classifications on the basis of the contractor's needs and the availability of journeymen in the various classifications within a reasonable area of recruitment.

No employee shall be employed as a trainee in any classification in which they have successfully completed a training course leading to journeyman level status or in which they have been employed as a journeyman.

Records and Reports

The Contractor shall maintain enrollment, monthly and completion reports documenting company compliance under these contract documents. These documents and any other information as requested shall be submitted to the OJT Program Manager.

Upon completion and graduation of the program, the Contractor shall provide each trainee with a certification Certificate showing the type and length of training satisfactorily completed.

Trainee Interviews

All trainees enrolled in the program will receive an initial and Trainee/Post graduate interview conducted by the OJT program staff.

Trainee Wages

Contractors shall compensate trainees on a graduating pay scale based upon a percentage of the prevailing minimum journeyman wages (Davis-Bacon Act). Minimum pay shall be as follows:

60 percent	of the journeyman wage for the first half of the training period
75 percent	of the journeyman wage for the third quarter of the training period
90 percent	of the journeyman wage for the last quarter of the training period

In no instance shall a trainee be paid less than the local minimum wage. The Contractor shall adhere to the minimum hourly wage rate that will satisfy both the NC Department of Labor (NCDOL) and the Department.

Achieving or Failing to Meet Training Goals

The Contractor will be credited for each trainee employed by him on the contract work who is currently enrolled or becomes enrolled in an approved program and who receives training for at least 50 percent of the specific program requirement. Trainees will be allowed to be transferred between projects if required by the Contractor's scheduled workload to meet training goals.

If a contractor fails to attain their training assignments for the calendar year, they may be taken off the NCDOT's Bidders List.

Measurement and Payment

No compensation will be made for providing required training in accordance with these contract documents.

STANDARD SPECIAL PROVISION

NAME CHANGE FOR NCDENR

(1-19-16)

Z-11

Description

Wherever in the 2012 Standard Specifications, Project Special Provisions, Standard Special Provisions, Permits or Plans that reference is made to “NCDENR” or “North Carolina Department of Environment and Natural Resources”, replace with “NCDEQ” or “North Carolina Department of Environmental Quality” respectively, as the case may be.

PROJECT SPECIAL PROVISIONS

GEOTECHNICAL

PILES (LRFD) - (10/20/2015)

GT-1.1 - GT-1.2

DRILLED PIERS (LRFD) - (10/20/2015)

GT-2.1 - GT-2.2

GEOTEXTILE FOR PAVEMENT STABILIZATION - (1/21/2014)

GT-3.1 - GT-3.2

DocuSigned by:
Geotechnical Engineering Unit
E06538624A11498...

PILES**(10-20-15)**

Revise the *2012 Standard Specifications* as follows:

Page 4-70, Article 450-2, Materials, line 2, in the materials table, replace “Neat Cement Grout, Nonshrink” with “Neat Cement Grout, Type 1”.

Page 4-70, Article 450-2, Materials, line 8, in the last sentence of the second paragraph, replace “approved by the Materials and Tests Unit.” with “that are on the NCDOT Approved Products List.”

Page 4-72, Subarticle 450-3(D)(3), Required Driving Resistance, lines 26-30, replace first paragraph with the following:

The Engineer will determine if the proposed pile driving methods and equipment are acceptable and provide the blows/ft and equivalent set for the required driving resistance noted in the plans, i.e., “pile driving criteria” except for structures with pile driving analyzer (PDA) testing. For structures with PDA testing, provide pile driving criteria for any bents and end bents with piles in accordance with Subarticle 450-3(F)(4).

Page 4-73, Subarticle 450-3(E)(1), Pile Excavation, lines 19-20, in the third sentence of the second paragraph, replace “use smooth or corrugated clean watertight steel casings” with “use smooth non-corrugated clean watertight steel casings”.

Page 4-73, Subarticle 450-3(F), Pile Driving Analyzer, lines 45-48, replace third paragraph with the following:

The Engineer will complete the review of the proposed pile driving methods and equipment within 7 days of receiving PDA reports and pile driving criteria. Do not place concrete for caps or footings on piles until PDA reports and pile driving criteria have been accepted.

Page 4-75, Subarticle 450-3(F), Pile Driving Analyzer, line 21, add the following to the end of Article 450-3:

(4) Pile Driving Criteria

Analyze pile driving with the GRL Wave Equation Analysis Program (GRLWEAP) manufactured by Pile Dynamics, Inc. Use the same PDA Consultant that provides PDA reports to perform GRLWEAP analyses and develop pile driving criteria. Provide driving criteria sealed by an engineer approved as a Project Engineer (key person) for the same PDA Consultant.

Analyze pile driving so driving stresses, energy transfer, ram stroke and blows/ft from PDA testing and resistances from CAPWAP analyses correlate to GRLWEAP models. Provide pile driving criteria for each combination of required driving resistance and pile length installed for all pile types and sizes. Submit 2 copies of pile driving criteria with

PDA reports. Include the following for driving criteria:

- (a) Project information in accordance with Subarticle 450-3(F)(3)(a)
- (b) Table showing blows/ft and equivalent set vs. either stroke for multiple strokes in increments of 6" or bounce chamber pressure for multiple pressures in increments of 1 psi
- (c) Maximum stroke or blows/ft or pile cushion requirements to prevent overstressing piles as needed
- (d) GRLWEAP software version information
- (e) PDF copy of all pile driving criteria and executable GRLWEAP input and output files

Page 4-76, Article 450-4, Measurement and Payment, lines 27-29, replace third sentence of the sixth paragraph with the following:

The contract unit price for *PDA Testing* will be full compensation for performing PDA testing the first time a pile is tested, performing CAPWAP analysis on data collected during initial drive, restrikes and redrives, providing PDA reports, performing GRLWEAP analysis and developing and providing pile driving criteria.



DocuSigned by:
Scott A. Hidden
F760CAEB96FC4D3...

1/8/2016

DRILLED PIERS**(10-20-15)**

Revise the *2012 Standard Specifications* as follows:

Page 4-9, Article 411-1, Description, line 12, replace second sentence in the second paragraph with the following:

Define “permanent casing” as a casing that remains in the excavation and acts as a form for Drilled Pier concrete and “temporary casing” as any casing that is not permanent. Define “rock” as a continuous intact natural material with a standard penetration resistance of 0.1 ft or less per 60 blows or a rock auger penetration rate of less than 2" per 5 minutes of drilling at full crowd force or as determined by the Engineer when rock is not encountered as expected based on these criteria.

Page 4-9, Article 411-2, Materials, line 18, in materials table, replace “Grout, Nonshrink” with “Grout, Type 2”.

Page 4-9, Subarticle 411-2(A), Steel Casing, line 26, add the following after first sentence in the first paragraph:

If permanent casing is required for an excavation, the largest diameter casing in the hole is the permanent casing. This does not apply to working casings around permanent casings as approved by the Engineer.

Page 4-12, Subarticle 411-3(B), Preconstruction Meeting, line 22, replace with the following:

(A) Preconstruction Meeting

Before starting drilled pier construction, hold a preconstruction meeting to discuss the installation, monitoring and inspection of the drilled piers. Schedule this meeting after the Drilled Pier Contractor mobilizes to the site. If this meeting occurs before all drilled pier submittals have been accepted, additional preconstruction meetings may be required before beginning construction of drilled piers without accepted submittals. The Resident or Bridge Maintenance Engineer, Bridge Construction Engineer, Geotechnical Operations Engineer, Contractor and Drilled Pier Contractor Superintendent will attend preconstruction meetings.

Page 4-12, Article 411-4, Construction Methods, lines 37-39, replace with the following:

For drilled piers constructed with slurry or permanent casings, the pier diameter may be 2" less than the design pier diameter shown in the plans. For all other drilled piers, construct piers with the minimum required diameters shown in the plans except for portions of drilled piers in rock which may be 2" less than the design pier diameter.

Page 4-13, Subarticle 411-4(A), Excavation, line 11, add the following after second sentence in the third paragraph:

See Articles 107-11 and 107-12 for protection of public and private property and control of siltation, dust and air and water pollution from blasting, drilling and excavating with down-the-hole hammers.



DocuSigned by:
Scott A. Hidden
F760CAEB96FC4D3...

1/8/2016

GEOTEXTILE FOR PAVEMENT STABILIZATION:**(1-21-14)****Description**

Furnish and place geotextile for pavement stabilization in accordance with the contract. Geotextile for pavement stabilization may be required to prevent pavement cracking and provide separation between the subgrade and pavement section at locations shown in the plans and as directed.

Materials

Refer to Division 10 of the *Standard Specifications*.

Item

Geotextiles

Section

1056

Provide Type 5 geotextile for geotextile for pavement stabilization that meets the following requirements:

GEOTEXTILE FOR PAVEMENT STABILIZATION REQUIREMENTS		
Property	Requirement (MARV^A)	Test Method
Tensile Strength @ 5% Strain (MD & CD ^A)	1,900 lb/ft	ASTM D4595
Ultimate Tensile Strength (MD & CD ^A)	4,800 lb/ft	ASTM D4595
Melting Point	300° F	ASTM D276

A. Define “minimum average roll value” (MARV), “machine direction” (MD) and “cross-machine direction” (CD) in accordance with ASTM D4439.

Construction Methods

Notify the Engineer when the roadbed is completed within 2" of subgrade elevation. The Engineer will sample and test subgrade soils for quality to determine if geotextile for pavement stabilization is required at locations shown in the plans and other locations as directed. For subgrades without stabilization, allow 24 days to determine if geotextile for pavement stabilization is required. For stabilized subgrades with geotextile for pavement stabilization, stabilize subgrade soils to 12" beyond the base course as shown in the plans.

Place geotextile for pavement stabilization on subgrades immediately below pavement sections as shown in the plans and in slight tension free of kinks, folds, wrinkles or creases. Install geotextiles with the MD perpendicular to the roadway centerline. The MD is the direction of the length or long dimension of the geotextile roll. Do not splice or overlap geotextiles in the MD so splices or overlaps are parallel to the roadway centerline. Extend geotextile for pavement stabilization 12" beyond the base course as shown in the plans.

Completely cover subgrades with geotextile for pavement stabilization so geotextiles are adjacent to each other in the CD, i.e., perpendicular to the MD. The CD is the direction of the width or short dimension of the geotextile roll. Overlapping geotextiles in the CD is permitted but not required. Overlap geotextiles in the direction that base course will be placed to prevent lifting the edge of the top geotextile.

For asphalt base courses, asphalt mixture temperatures in the truck may not exceed 315° F at the time of placement. Do not damage geotextile for pavement stabilization when constructing base

courses. Place and compact base courses in accordance with the *Standard Specifications*. Do not operate heavy equipment on geotextiles any more than necessary to construct pavement sections. Replace any damaged geotextiles to the satisfaction of the Engineer.

Measurement and Payment

Geotextile for Pavement Stabilization will be measured and paid in square yards. Geotextiles will be measured along subgrades as the square yards of exposed geotextiles before placing base courses. No measurement will be made for overlapping geotextiles. The contract unit price for *Geotextile for Pavement Stabilization* will be full compensation for providing, transporting and placing geotextiles.

Payment will be made under:

Pay Item

Geotextile for Pavement Stabilization

Pay Unit

Square Yard



DocuSigned by:
Scott A. Hidden
F760CAEB96FC4D3...

1/8/2016

TC-1

U-2707

Forsyth County

WORK ZONE TRAFFIC CONTROL Project Special Provisions

Law Enforcement:

(05/14/2013)

Description

Furnish Law Enforcement Officers and marked Law Enforcement vehicles to direct traffic in accordance with the contract.

Construction Methods

Use uniformed Law Enforcement Officers and marked Law Enforcement vehicles equipped with blue lights mounted on top of the vehicle, and Law Enforcement vehicle emblems to direct or control traffic as required by the plans or by the Engineer.

Measurement and Payment

Law Enforcement will be measured and paid for in the actual number of hours that each Law Enforcement Officer is provided during the life of the project as approved by the Engineer. There will be no direct payment for marked Law Enforcement vehicles as they are considered incidental to the pay item.

Payment will be made under:

Pay Item

Law Enforcement

Pay Unit

Hour

DocuSigned by:

David Bissette

ECDC908C875348C...

12/17/2015



UC-1

Project: U-2707

County: Forsyth

PROJECT SPECIAL PROVISIONS Utility Construction

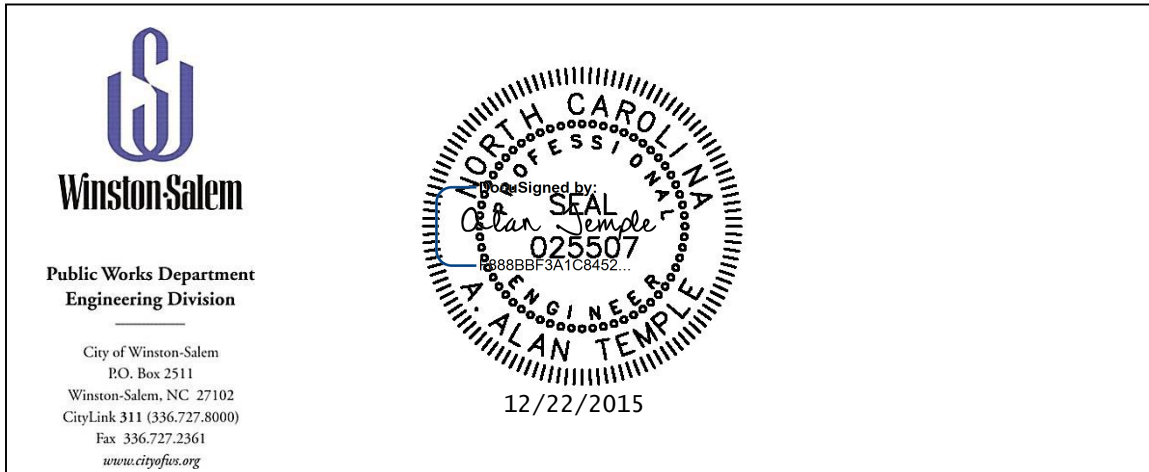

Revise the 2012 Standard Specifications as follows:

Page 10-58, Sub-article 1036-4(B) Encasement Pipe:
add the following paragraph:

Casing spacers shall be made of Type 304 stainless steel (including risers and hardware). Each shell shall be PVC lined and shall have bolted flanges. Casing spacer runners shall be constructed of ultra high molecular weight polymer (minimum 1 ½” wide) with a friction coefficient of not more than .12. Risers shall be 10 gauge. Risers and runners for top and bottom shells shall be of equal height. With approval of the Engineer, unequal height risers and runners may be used to obtain proper grade for sanitary sewer mains. Casing spacers must be designed to ensure that only the runners of the spacer are in contact with the steel encasement pipe. The bell of the carrier pipe will not be allowed to be in contact with the encasement. Casing spacers shall be manufactured by one of the following or approved equal:

- (1) Cascade Waterworks Manufacturing Company
- (2) Advance Products and Systems, Inc.
- (3) BWM Company

Page 10-58, Sub-article 1036-1 General
add the following sentence:

All materials in contact with potable water shall be in conformance with Section 1417 of the Safe Drinking Water Act.

UC-2

Project: U-2707

County: Forsyth

PROJECT SPECIAL PROVISIONS Utility Construction

Page 10-58, Sub-article 1036-5 Ductile Iron Pipe and Fittings:

replace with the following:

Ductile iron pipe shall be designed to conform to ANSI A21.50 (AWWA C150) and shall be manufactured to conform to ANSI A21.51 (AWWA C151). The interior of pipe for water will be cement lined in accordance with ANSI A21.4 (AWWA C104). The interior of pipe for sanitary sewer will be lined with 40 mils of Protecto 401 Ceramic Epoxy. All bells and spigots for sanitary sewer pipe must be lined with a minimum of 8 mils of Protecto 401 Joint Compound or approved equal. The exterior of all pipe shall be coated with a bituminous coating. Pipe joints will be single rubber gasket push-on type or mechanical joint type unless otherwise specified or otherwise shown on the Engineer's drawings. Rubber gasket joints shall conform to ANSI A21.11 (AWWA C111). Pipe design laying condition will be Type 2, flat-bottom trench with backfill lightly consolidated to centerline of pipe. Pipe for sanitary sewer shall be minimum thickness Class 50. Pipe for water shall be pressure Class 350 for 3" - 16" and pressure Class 250 for 18" and above. Any deviations in class shall be otherwise specified or otherwise shown on the Engineer's drawings.

Ductile iron flexible restrained joint pipe shall be installed at the locations shown on the Engineer's drawings. All restrained joint pipe shall have flexible push-on joints designed to deflect a minimum of 3° per joint. At locations where field cutting of restrained joint pipe is required, a special field cut kit shall be used by the Contractor. Field welding will not be allowed. Field cut kits shall provide restraint equivalent to factory manufactured restrained joint pipe. Field kits shall be provided by the pipe manufacturer. Restrained joint pipe with a gripping gasket as the only means of restraint will not be allowed. Pipe shall be Flex- Ring by American, TR Flex by U.S. Pipe, Snap-Lok by Griffin, Super-Lock by Clow or approved equal.

Ductile iron fittings shall meet all requirements of ANSI A21.10 (AWWA C110) and will be of the mechanical joint type unless otherwise specified. All glands shall be ductile iron, not gray iron. The interior of fittings for water will be cement lined in accordance with ANSI A21.4 (AWWA C104). The interior of fittings for sanitary sewer will be lined with 40 mils of Protecto 401 Ceramic Epoxy. All bells and spigots for sanitary sewer fittings must be lined with a minimum of 8 mils of Protecto 401 Joint Compound or approved equal. The exterior of all fittings shall be coated with a bituminous coating. Fittings coated on the interior and exterior with 8 mils of fusion bonded epoxy in accordance with ANSI/AWWA C116 and ANSI/AWWA C550 are acceptable. Fittings will have a minimum pressure rating of 250 psi unless otherwise specified by the Engineer. All Fittings are subject to approval by the Engineer, and his acceptance or rejection shall be final. Rubber gasket joints shall conform to ANSI A21.11 (AWWA C111). Ductile iron compact fittings conforming to ANSI A21.53 (AWWA C153) are acceptable. "DI" or "Ductile" shall be cast on each fitting.

UC-3

Project: U-2707

County: Forsyth

PROJECT SPECIAL PROVISIONS Utility Construction

Page 10-59, Sub-article 1036-6 Fire Hydrants:

add the following:

Hydrants accepted by the City of Winston-Salem are as follows (or approved equal):

- (1) Super Centurion 250, manufactured by Mueller Company
- (2) MK-73-5, manufactured by American Flow Control
- (3) K-81D Guardian, manufactured by Kennedy Valve Company

Page 10-59, Sub-article 1036-7 (A) Gate Valves:

replace with the following:

All gate valves shall be resilient-seated gate valves which meet the specifications of ANSI/AWWA C509 or ANSI/AWWA C515. The valve body, bonnet and seal plate shall be coated on all exterior and interior surfaces with a minimum of 8-10 mils of fusion bonded epoxy in accordance with ANSI/AWWA C550. The valve shall incorporate a guide system with guide lugs on the wedge or on the body. The wedge shall be gray or ductile iron, fully encapsulated with rubber (including guide lugs and stem nut holder). Non-rising stem valves shall have two O-ring seals above the stem thrust collar that can be replaced with the valve under pressure. Non-rising stem valves shall also have a thrust washer on the stem thrust collar. Valves used for buried service will have a non-rising stem, mechanical joint end connections, and a 2" square operating nut. The word "OPEN" and an arrow to indicate the direction of opening the valve shall be cast on the flanged base of the operating nut. Above ground valves, unless otherwise specified, will have an outside screw and yoke rising stem or a non-rising stem, flanged end connections, and a handwheel to operate the valve. The word "OPEN" and an arrow to indicate the direction of opening the valve shall be cast on the rim of the handwheel. All valves will open by turning the nut or handwheel counterclockwise. Valves installed in manholes will normally be considered to be buried service valves and valves installed in vaults will normally be considered to be above ground valves.

Resilient-seated gate valves shall be designed for a minimum working pressure of 250 psi. Each valve shall be seat tested at the rated working pressure and shell tested at twice the rated working pressure in accordance with ANSI/AWWA C509 - Section 5 or ANSI/AWWA C515 - Section 5. All valves shall be warranted for 10 years from date of purchase against defective materials and workmanship. Gate valves furnished under these specifications must be manufactured by one of the following or approved equal:

- (1) Clow Valve Company
- (2) M & H Valve Company
- (3) American Flow Control
- (4) U.S. Pipe and Foundry Company

UC-4

Project: U-2707

County: Forsyth

PROJECT SPECIAL PROVISIONS Utility Construction

- (5) Mueller Company
- (6) Kennedy Valve Company

Page 10-59, Sub-article 1036-7 (C) Tapping Valves:
replace with the following:

Use tapping valves conforming to Sub-article 1036-7 (A) with appropriately sized openings, with flanged by mechanical joint ends and pressure rated at 250 psi.

Page 10-59, Sub-article 1036-8 (A) Tapping Sleeves:
replace with the following:

Tapping sleeves shall be a split sleeve with mechanical joint end connections and a flanged outlet. Sleeves shall be designed for a minimum working pressure of 200 psi.

Approved tapping sleeves are as follows (or approved equal):

- (1) Mueller Company
- (2) American Flow Control
- (3) Tyler Pipe Company
- (4) U.S. Pipe and Foundry Company
- (5) Kennedy Valve Company

Page 10-59, Sub-article 1036-8 Sleeves, Couplings and Miscellaneous:
add the following:

(C) Valve Boxes

Cast iron valve boxes will conform to ASTM A48, Class 30B. All boxes will conform to the shape and dimensions shown on the City of Winston-Salem detail drawings and will be free from holes, cracks or any other defects. All castings will be thoroughly coated with an asphaltic varnish. The name of the manufacturer shall be permanently cast on each piece. Valve boxes that do not meet specifications shall be rejected. Cast iron valve boxes furnished under these specifications shall be manufactured by one of the following or approved equal:

- (1) Sigma Corp.
- (2) SIP Industries
- (3) DSI International

Page 10-59, Sub-article 1036-9 Service Line Valves and Fittings:
add the following:

UC-5

Project: U-2707

County: Forsyth

PROJECT SPECIAL PROVISIONS Utility Construction

All brass fittings shall be manufactured in accordance with AWWA C800 and ASTM B-584. All brass components in contact with potable water must be made from CDA/UNS Brass Alloy C89833 with a maximum lead content of .25% by weight. Brass alloys not listed in ANSI/AWWA C800 Paragraph 4.1.2 are not approved. All fittings shall be UL classified to NSF/ANSI 61 and NSF/ANSI 372 standards and stamped or embossed with a mark or name indicating that the product is manufactured from the low-lead alloy as specified.

Page 15-1, Sub-article 1500-2 Cooperation with the Utility Owner, paragraph 2:
add the following sentences:

The utility owner is the Winston-Salem/Forsyth County Utilities Commission. The contact person is David Doss and he can be reached by phone at (336) 727-8063.

The materials and appurtenances installed by the contractor shall require approval by both NCDOT and the utility owner prior to installation.

Page 15-4, Sub-article 1505-3 (E), Thrust Restraint:
replace the fourth paragraph with the following:

All thrust blocks will be constructed of a minimum of Class A concrete. Thrust blocks for horizontal bends and fire hydrants shall be constructed in accordance with the City of Winston-Salem detail drawings. All blocking for vertical bends shall be designed and/or approved by the Engineer. On tie-in sections, the Contractor may be required by the Engineer, to anchor pipe bends, tees, etc. with precast concrete blocking, steel beams, rodding or other approved method to allow the water line to be placed back into service as soon as possible. Polyethylene shall be placed over all fittings before the concrete is poured. All nuts and bolts shall be clear of concrete so that the joint will be accessible. Plywood shall be used as forms for blocking. Concrete is to be poured only against stable undisturbed soil and should be allowed to set prior to any backfilling. Thrust blocks should be allowed to cure two days prior to pressure testing the water main. Higher strength concrete may be required when it is necessary to pressure test prior to the end of the two day curing time.

Page 15-6, Sub-article 1510-3 (B), Testing and Sterilization:
change the allowable leakage formula to:

$$W = LD\sqrt{P} \div 148,000$$

UC-6

Project: U-2707

County: Forsyth

PROJECT SPECIAL PROVISIONS Utility Construction

Page 15-6, Sub-article 1510-3 (B), Testing and Sterilization, sixth paragraph:

Replace the paragraph with the following:

Sterilize water lines in accordance with Section 1003 of The Rules Governing Public Water supply and AWWA C651 Section 4.4.3, the Continuous Feed Method. Provide a chlorine solution with between 50 parts per million and 100 parts per million in the initial feed. If the chlorine level drops below 10 parts per million during a 24 hour period, then flush, refill with fresh chlorine solution, and repeat for 24 hours. Provide certified bacteriological and contaminant test results from a state-approved or state-certified laboratory. Operate all valves and controls to assure thorough sterilization.

Page 15-6, Sub-article 1510-3 (B), Testing and Sterilization, seventh paragraph:

delete the words "may be performed concurrently or consecutively."
and replace with "shall be performed consecutively."

Page 15-7, Sub-article 1515-3 Construction Methods:

add the following:

(H) Tapping Sleeves

Tapping sleeves shall be used for "wet" taps into existing water mains as indicated on the Engineer's drawings. The Contractor shall verify the type of material, size, etc., of the existing main prior to ordering the sleeve. All tapping sleeves and valves shall be water tested before the tap is made. Test pressure shall be 200 psi. All tapping sleeves and valves shall be installed level. The Engineer must be present during the entire tapping and testing process. Tapping sleeves are incidental to the valve installation.

Page 15-8, Sub-article 1515-3 (A), Valves:

add the following:

All valves 3" through 16" shall be gate valves.

Page 15-8, Sub-article 1515-3 (B), Meters:

add the following:

For existing service connections being replaced:
Prior to connecting the dwelling or business to the new meter, the Contractor shall expose a portion of the water line from the dwelling or business to determine the material and have proper fittings for reconnection to the new meter box. After the new water line and connections have been pressure tested & disinfected & approved by the Engineer, the Contractor shall remove the existing meter and install it in the new yoke. The Contractor shall reconnect the dwelling or business side water line to the new meter box. This

UC-7

Project: U-2707

County: Forsyth

PROJECT SPECIAL PROVISIONS Utility Construction

reconnection shall be directed by the Engineer and performed in a timely manner so that the dwelling or business is without water for a minimal time. The cost of work performed to connect the dwelling or business to the new meter shall be included in the contract unit price bid for ___" Water Meter unless otherwise noted.

For relocated meters (with change to horizontal location):

The Contractor shall install a new meter box, angle valves, yoke, tee and ball valve as directed by the Engineer. The Contractor shall expose a portion of the water line from the dwelling or business to determine the material and have proper fittings for reconnection to the new meter box. At the approval of the Engineer, the Contractor shall remove the existing meter and install it in the new yoke. The Contractor shall reconnect the property side water line from the existing meter box to the new meter box. This reconnection shall be directed by the Engineer and performed in a timely manner so that the property is without water for a minimal amount of time. The Contractor shall remove and dispose of the existing meter box and yoke and backfill as shown on the plans or as directed by the Engineer.

Page 15-8, Sub-article 1515-3 (D), Hydrants:

add the following:

Any fire hydrant removed for relocation purposes shall be delivered by the Contractor to the City's Utilities Construction and Maintenance Department. The Contractor shall furnish and install a new fire hydrant.

Page 15-9, Sub-article 1515-4, Measurement and Payment:

Add the following:

For new and relocated 3/4" & 1" water connections, The Contractor shall install connection per detail VII-46.

For new and relocated 1-1/2" & 2" water connections, The Contractor shall install connection per detail VII-50.

Page 15-10, Sub-article 1520-2 Materials:

Delete line 11.

Page 15-11, Sub-article 1520-3 (A) (2) Testing:

replace with the following:

UC-8

Project: U-2707

County: Forsyth

PROJECT SPECIAL PROVISIONS Utility Construction

(2) Testing

(a) Infiltration, Exfiltration and Air Test

After the pipeline is completely backfilled and before being placed into service, a low-pressure air test with an approved pressure gauge will be conducted by the Contractor in accordance with ASTM C-828. Each section of pipeline (including connections) between manholes will be tested by plugging the upstream manhole and the downstream manhole. By using mirrors, lights, etc., the Contractor must show the Engineer that the 2 plugs are at the proper location and that the line is clear between the plugs. Air is added to the line until the pressure is between 3.0 psi and 4.0 psi. If the pressure drops more than 1.0 psi during the time shown on the chart below, the line is presumed to have failed the test. If the top of the pipe to be tested is below the ground water table, an infiltration test may be required. Infiltration shall not exceed 100 gallons per inch diameter per mile of pipe per 24 hours. An obvious leak in any section will be corrected even if the section passes testing. The Engineer must be present during the entire testing process. Any work done without his supervision will not be accepted. Air testing will be required for pipelines 42" and smaller. Larger pipelines will require infiltration and/or exfiltration testing. Exfiltration limits shall be the same as infiltration.

Air test time shall be as follows:

MINIMUM AIR TEST TIME

<u>Main Size</u>	<u>Time (minutes per 100 feet of pipe)</u>
8"	1.5
10"	1.8
12"	2.1
15"	2.4
18"	2.7
21"	3.3
24"	3.9
27"	4.5
30"	5.1
36"	6.3
42"	7.6

(b) Video Inspection

As a final measure required for acceptance, the Contractor shall clean and televise all sanitary sewer mains prior to requesting final inspection. The Contractor shall televise the entire sewer main and all service connections using standardized NASSCO (PACP, MACP, & LACP) practices, unless otherwise specified below. The process shall begin at

UC-9

Project: U-2707

County: Forsyth

PROJECT SPECIAL PROVISIONS Utility Construction

the upstream manhole for each segment, and proceed to the downstream manhole for that same segment. Connections shall be televised from the cleanout to the main. Video inspection may occur only after Record Drawings are accepted and approved by the City of Winston-Salem. Prior to beginning the process, a 24 hour notice must be given by the Contractor to the Engineer. Prior to video inspection in paved areas, structures must be raised to final grade and 2" of asphalt must be in place. The City will not accept video that is more than 180 days old unless approved by the Engineer.

The cameras used for inspection shall be ones specifically designed and constructed for sanitary sewer pipeline inspection. Lighting for the cameras shall be suitable to provide a clear color picture of the entire periphery of the pipe. The cameras used for mains must be able to pan, tilt and zoom in order to allow for 360 degree viewing. The television system shall be equipped to indicate the camera travel distance in feet by display on the video viewing screen. All television equipment (camera, monitor, etc.) must be capable of producing picture quality which is satisfactory to the Engineer.

Within 2 hours of the video inspection, the Contractor shall clean the sewer mains and service connections with a high velocity water jet. All debris shall be collected in the downstream manhole and removed by the Contractor. Debris shall not be released into the existing sewer system. During the entire video process, the distance counter must be set at zero at each upstream manhole for each segment (set the counter at zero at the ground for each service connection). The Contractor will be required to pan and tilt at each manhole and at each service connection. The interior of each manhole must be marked with the manhole station (or manhole number) with paint or some other legible identifier (6" - 12" high letters or numbers). Each cleanout stack must be marked with the house number or the lot number. For mains, the Contractor will also be required to pan, tilt and zoom at all couplings, at all dates for Protecto 401 lined ductile iron pipe, and when any potential problems or abnormalities are noticed or suspected. Travel speed for the camera will be 15 - 30 feet per minute. The following video screen data will be required:

- Project name and project number
- Date of inspection
- Travel distance and time
- Station of start and end manholes
- Depth of start and end manholes
- Size of main
- Type of pipe

All above data shall be shown at the start and end manholes of each segment. While the camera is moving through the main and service connections, distance shall be the only data shown on the screen (top left or top right of screen).

UC-10

Project: U-2707

County: Forsyth

PROJECT SPECIAL PROVISIONS Utility Construction

For mains, a stream of water approximately 1" in width must be flowing during the entire video process. For service connections, a minimum of 5 gallons of water must be introduced into each cleanout stack just prior to the video process. In all cases, the flow must be shown on the bottom of the video screen.

Two copies of the entire video inspection shall be submitted to the Engineer on a data disc (DVD or flash drive). The video file shall be formatted to MPEG-4 (MP4) with software compatible and readable by the City of Winston-Salem. The City of Winston-Salem shall not be responsible for purchasing additional software necessary to view the video file. Each inspection (manhole to manhole or cleanout to main) shall be separated into its own chapter or file. In the event of a main inspection, the chapter or file shall be named to indicate the upstream manhole station or number and then the downstream manhole station or number (e.g. MH1-MH2). In the event of a service connection inspection, the chapter or file shall be named to indicate the house number or lot number associated with the inspection. All file naming should match the identification numbers (manhole station or number, house number, or lot number) shown on the Record Drawings.

Any video that does not clearly show the pipe and service connections will be rejected. In the event that repairs are made, the segment receiving the repairs shall be flushed and televised again. The Engineer must oversee the entire cleaning and televising process. Final approval of the video inspection will only be after the Engineer has reviewed the video in the office (videos will not be field approved).

Page 15-13, Sub-article 1525-2, Materials, lines 15-19:

Replace with the following:

Manhole rings and covers will be made of cast iron and will conform to ASTM A48, Class 35B. In addition, all manhole rings and covers shall be designed to support an H-20 wheel load. All castings will conform to the shape and dimensions shown on the City of Winston-Salem detail drawing and will be free from holes, cracks or any other defects. Rings and covers will have machined seats so that the cover will not rattle. Rings will weigh a minimum of 190 pounds and covers a minimum of 120 pounds. The name of the manufacturer and the part number shall be cast permanently on the ring and the cover. Castings that do not meet specifications shall be rejected.

Page 15-15, Sub-article 1530-3 (A), Abandoning Pipe:

add the following paragraph:

When abandoning water mains up to a main that is to remain in service, any valve or tee associated with the main to be abandoned shall be removed. A sleeve and any necessary piping shall be installed to reconnect the water main to remain in service. All other main line valves on abandoned water mains shall be abandoned by removing the valve box.

UC-11

Project: U-2707

County: Forsyth

PROJECT SPECIAL PROVISIONS Utility Construction

Water connections on abandoned mains shall be abandoned by removing and disposing of the existing meter box and yoke and backfill as shown on the plans or as directed by the Engineer. The work covered in this paragraph shall be considered incidental to the abandonment.

Page 15-17, Sub-article 1540-3 (D), Carrier Pipe Installation, lines 20-22:
replace with the following:

Encasement pipe shall be installed prior to laying the carrier pipe within 50 feet of either end of the encasement. Casing spacers are required and shall be placed at 10 foot intervals within the encasement. One spacer shall be placed not more than 2 feet from each end of the encasement. Only the runners of the casing spacer shall be in contact with the encasement. The bell of the carrier pipe will not be allowed to be in contact with the encasement. The Engineer must be present to observe the entire installation of the carrier pipe.

PROJECT SPECIAL PROVISIONS

Utilities by Others

General:

The following utility companies have facilities that will be in conflict with the construction of this project:

- A) Duke Energy (Power Distribution)
- B) AT&T of NC (Telephone)
- C) Time Warner Cable (CATV)

The conflicting facilities of these concerns will be adjusted prior to the date of availability, unless otherwise noted and are therefore listed in these special provisions for the benefit of the Contractor. All utility work listed herein will be done by the utility owners. All utilities are shown on the plans from the best available information.

The Contractor's attention is directed to Article 105-8 of the 2012 Standard Specifications.

Utilities Requiring Adjustment:

Utility relocations are shown on the Utilities by Others Plans.

- A) Duke Energy (Power Distribution)
 - 1) Duke Energy will have their conflicting facilities relocated by November 1, 2016.
 - 2) Contact person for Duke Energy:
Patrick Sizemore
Engineering and Construction Planning
Piedmont Northwest
Office: (336) 917-2522
Cell: (336) 416-8632
Fax: (336) 917-2510
Patrick.Sizemore@duke-energy.com
- B) AT&T of NC (Telephone)
 - 1) AT&T of NC will have their conflicting facilities relocated by December 1, 2016.
 - 2) Contact person for AT&T of NC:
Ron Stokes
Project Specialist
TELICS
5173 Gum Tree Road
Winston-Salem, North Carolina 27107
Office: (336) 788-0150

PROJECT SPECIAL PROVISIONS

Utilities by Others

Cell: (336) 682-1090

rs7737@att.com

C) Time Warner Cable (CATV)

1) Time Warner will have their conflicting facilities relocated by December 1, 2016.

2) Contact person for Time Warner Cable:

Eric D. Vivod

Construction Coordinator III

Time Warner Cable

1410 Trade Mart Boulevard

Winston Salem, North Carolina 27409

Office: (336) 231-6109

Cell: (336) 382-3282

Eric.vivod@twcable.com

**Project Special Provisions
Erosion Control**

STABILIZATION REQUIREMENTS:

Stabilization for this project shall comply with the time frame guidelines as specified by the NCG-010000 general construction permit effective August 3, 2011 issued by the North Carolina Department of Environment and Natural Resources Division of Water Quality. Temporary or permanent ground cover stabilization shall occur within 7 calendar days from the last land-disturbing activity, with the following exceptions in which temporary or permanent ground cover shall be provided in 14 calendar days from the last land-disturbing activity:

- Slopes between 2:1 and 3:1, with a slope length of 10 ft. or less
- Slopes 3:1 or flatter, with a slope of length of 50 ft. or less
- Slopes 4:1 or flatter

The stabilization timeframe for High Quality Water (HQW) Zones shall be 7 calendar days with no exceptions for slope grades or lengths. High Quality Water Zones (HQW) Zones are defined by North Carolina Administrative Code 15A NCAC 04A.0105 (25). Temporary and permanent ground cover stabilization shall be achieved in accordance with the provisions in this contract and as directed.

SEEDING AND MULCHING:

(West)

The kinds of seed and fertilizer, and the rates of application of seed, fertilizer, and limestone, shall be as stated below. During periods of overlapping dates, the kind of seed to be used shall be determined. All rates are in pounds per acre.

Shoulder and Median Areas

August 1 - June 1

20#	Kentucky Bluegrass
75#	Hard Fescue
25#	Rye Grain
500#	Fertilizer
4000#	Limestone

May 1 - September 1

20#	Kentucky Bluegrass
75#	Hard Fescue
10#	German or Browntop Millet
500#	Fertilizer
4000#	Limestone

Areas Beyond the Mowing Pattern, Waste and Borrow Areas:

August 1 - June 1

100#	Tall Fescue
15#	Kentucky Bluegrass
30#	Hard Fescue
25#	Rye Grain
500#	Fertilizer
4000#	Limestone

May 1 - September 1

100#	Tall Fescue
15#	Kentucky Bluegrass
30#	Hard Fescue
10#	German or Browntop Millet
500#	Fertilizer
4000#	Limestone

Approved Tall Fescue Cultivars

06 Dust	Escalade	Justice	Scorpion
2 nd Millennium	Essential	Kalahari	Serengeti
3 rd Millennium	Evergreen 2	Kentucky 31*	Shelby
Apache III	Falcon IV	Kitty Hawk 2000	Sheridan
Avenger	Falcon NG	Legitimate	Signia
Barlexas	Falcon V	Lexington	Silver Hawk
Barlexas II	Faith	LSD	Sliverstar
Bar Fa	Fat Cat	Magellan	Shenandoah Elite
Barrera	Festnova	Matador	Sidewinder
Barrington	Fidelity	Millennium SRP	Skyline
Barrobusto	Finelawn Elite	Monet	Solara
Barvado	Finelawn Xpress	Mustang 4	Southern Choice II
Biltmore	Finesse II	Ninja 2	Speedway
Bingo	Firebird	Ol' Glory	Spyder LS
Bizem	Firecracker LS	Olympic Gold	Sunset Gold
Blackwatch	Firenza	Padre	Taccoa
Blade Runner II	Five Point	Patagonia	Tanzania
Bonsai	Focus	Pedigree	Trio
Braveheart	Forte	Picasso	Tahoe II
Bravo	Garrison	Piedmont	Talladega
Bullseye	Gazelle II	Plantation	Tarheel
Cannavaro	Gold Medallion	Proseeds 5301	Terrano
Catalyst	Grande 3	Prospect	Titan ltd
Cayenne	Greenbrooks	Pure Gold	Titanium LS
Cessane Rz	Greenkeeper	Quest	Tracer
Chipper	Gremlin	Raptor II	Traverse SRP
Cochise IV	Greystone	Rebel Exeda	Tulsa Time
Constitution	Guardian 21	Rebel Sentry	Turbo
Corgi	Guardian 41	Rebel IV	Turbo RZ
Corona	Hemi	Regiment II	Tuxedo RZ
Coyote	Honky Tonk	Regenerate	Ultimate
Darlington	Hot Rod	Rendition	Venture
Davinci	Hunter	Rhambler 2 SRP	Umbrella
Desire	Inferno	Rembrandt	Van Gogh
Dominion	Innovator	Reunion	Watchdog
Dynamic	Integrity	Riverside	Wolfpack II
Dynasty	Jaguar 3	RNP	Xtremegreen
Endeavor	Jamboree	Rocket	

***Note: Kentucky 31 will no longer be an approved NCDOT Tall Fescue Cultivar after December 31, 2015.**

Approved Kentucky Bluegrass Cultivars:

4-Season	Blue Velvet	Gladstone	Quantum Leap
Alexa II	Blueberry	Granite	Rambo
America	Boomerang	Hampton	Rhapsody
Apollo	Brilliant	Harmonie	Rhythm
Arcadia	Cabernet	Impact	Rita
Aries	Champagne	Jefferson	Royce
Armada	Champlain	Juliet	Rubicon
Arrow	Chicago II	Jump Start	Rugby II
Arrowhead	Corsair	Keeneland	Shiraz
Aura	Courtyard	Langara	Showcase
Avid	Delight	Liberator	Skye
Award	Diva	Madison	Solar Eclipse
Awesome	Dynamo	Mercury	Sonoma
Bandera	Eagleton	Midnight	Sorbonne
Barduke	Emblem	Midnight II	Starburst
Barnique	Empire	Moon Shadow	Sudden Impact
Baroness	Envicta	Moonlight SLT	Total Eclipse
Barrister	Everest	Mystere	Touche
Barvette HGT	Everglade	Nu Destiny	Tsunami
Bedazzled	Excursion	NuChicago	Unique
Belissimo	Freedom II	NuGlade	Valor
Bewitched	Freedom III	Odyssey	Voyager II
Beyond	Front Page	Perfection	Washington
Blacksburg II	Futurity	Pinot	Zinfandel
Blackstone	Gaelic	Princeton 105	
Blue Note	Ginney II	Prosperity	

Approved Hard Fescue Cultivars:

Aurora II	Eureka II	Oxford	Scaldis II
Aurora Gold	Firefly	Reliant II	Spartan II
Berkshire	Granite	Reliant IV	Stonehenge
Bighorn GT	Heron	Rescue 911	
Chariot	Nordic	Rhino	

On cut and fill slopes 2:1 or steeper add 20# Sericea Lespedeza January 1 - December 31.

Fertilizer shall be 10-20-20 analysis. A different analysis of fertilizer may be used provided the 1-2-2 ratio is maintained and the rate of application adjusted to provide the same amount of plant food as a 10-20-20 analysis and as directed.

Native Grass Seeding And Mulching

(West)

Native Grass Seeding and Mulching shall be performed on the disturbed areas of wetlands and riparian areas, and adjacent to Stream Relocation and/or trout stream construction within a 50 foot zone on both sides of the stream or depression, measured from top of stream bank or center of depression. The stream bank of the stream relocation shall be seeded by a method that does not alter the typical cross section of the stream bank. Native Grass Seeding and Mulching shall also be performed in the permanent soil reinforcement mat section of preformed scour holes, and in other areas as directed.

The kinds of seed and fertilizer, and the rates of application of seed, fertilizer, and limestone, shall be as stated below. During periods of overlapping dates, the kind of seed to be used shall be determined. All rates are in pounds per acre.

August 1 - June 1

- 18# Creeping Red Fescue
- 8# Big Bluestem
- 6# Indiangrass
- 4# Switchgrass
- 35# Rye Grain
- 500# Fertilizer
- 4000# Limestone

May 1 – September 1

- 18# Creeping Red Fescue
- 8# Big Bluestem
- 6# Indiangrass
- 4# Switchgrass
- 25# German or Browntop Millet
- 500# Fertilizer
- 4000# Limestone

Approved Creeping Red Fescue Cultivars:

- Aberdeen
- Boreal
- Epic
- Cindy Lou

Fertilizer shall be 10-20-20 analysis. A different analysis of fertilizer may be used provided the 1-2-2 ratio is maintained and the rate of application adjusted to provide the same amount of plant food as a 10-20-20 analysis and as directed.

Native Grass Seeding and Mulching shall be performed in accordance with Section 1660 of the *Standard Specifications* and vegetative cover sufficient to restrain erosion shall be installed immediately following grade establishment.

Measurement and Payment

Native Grass *Seeding and Mulching* will be measured and paid for in accordance with Article 1660-8 of the *Standard Specifications*.

TEMPORARY SEEDING:

Fertilizer shall be the same analysis as specified for *Seeding and Mulching* and applied at the rate of 400 pounds and seeded at the rate of 50 pounds per acre. German Millet, or Browntop Millet shall be used in summer months and rye grain during the remainder of the year. The Engineer will determine the exact dates for using each kind of seed.

FERTILIZER TOPDRESSING:

Fertilizer used for topdressing shall be 16-8-8 grade and shall be applied at the rate of 500 pounds per acre. A different analysis of fertilizer may be used provided the 2-1-1 ratio is maintained and the rate of application adjusted to provide the same amount of plant food as 16-8-8 analysis and as directed.

SUPPLEMENTAL SEEDING:

The kinds of seed and proportions shall be the same as specified for *Seeding and Mulching*, and the rate of application may vary from 25# to 75# per acre. The actual rate per acre will be determined prior to the time of topdressing and the Contractor will be notified in writing of the rate per acre, total quantity needed, and areas on which to apply the supplemental seed. Minimum tillage equipment, consisting of a sod seeder shall be used for incorporating seed into the soil as to prevent disturbance of existing vegetation. A clodbuster (ball and chain) may be used where degree of slope prevents the use of a sod seeder.

MOWING:

The minimum mowing height on this project shall be six inches.

LAWN TYPE APPEARANCE:

All areas adjacent to lawns must be hand finished as directed to give a lawn type appearance. Remove all trash, debris, and stones $\frac{3}{4}$ " and larger in diameter or other obstructions that could interfere with providing a smooth lawn type appearance. These areas shall be reseeded to match their original vegetative conditions, unless directed otherwise by the Field Operations Engineer.

REFORESTATION:**Description**

Reforestation will be planted within interchanges and along the outside borders of the road, and in other areas as directed. *Reforestation* is not shown on the plan sheets. See the Reforestation Detail Sheet.

All non-maintained riparian buffers impacted by the placement of temporary fill or clearing activities shall be restored to the preconstruction contours and revegetated with native woody species.

The entire *Reforestation* operation shall comply with the requirements of Section 1670 of the *Standard Specifications*.

Materials

Reforestation shall be bare root seedlings 12"-18" tall.

Construction Methods

Reforestation shall be planted as soon as practical following permanent *Seeding and Mulching*. The seedlings shall be planted in a 16-foot wide swath adjacent to mowing pattern line, or as directed.

Root dip: The roots of reforestation seedlings shall be coated with a slurry of water, and either a fine clay (kaolin) or a superabsorbent that is designated as a bare root dip. The type, mixture ratio, method of application, and the time of application shall be submitted to the Engineer for approval.

With the approval of the Engineer, seedlings may be coated before delivery to the job or at the time of planting, but at no time shall the roots of the seedlings be allowed to dry out. The roots shall be moistened immediately prior to planting.

Seasonal Limitations: *Reforestation* shall be planted from November 15 through March 15.

Measurement and Payment

Reforestation will be measured and paid for in accordance with Article 1670-17 of the *Standard Specifications*.

RESPONSE FOR EROSION CONTROL:**Description**

Furnish the labor, materials, tools and equipment necessary to move personnel, equipment, and supplies to the project necessary for the pursuit of any or all of the following work as shown herein, by an approved subcontractor.

Section	Erosion Control Item	Unit
1605	Temporary Silt Fence	LF
1606	Special Sediment Control Fence	LF/TON
1615	Temporary Mulching	ACR
1620	Seed - Temporary Seeding	LB
1620	Fertilizer - Temporary Seeding	TN
1631	Matting for Erosion Control	SY
SP	Coir Fiber Mat	SY
1640	Coir Fiber Baffles	LF
SP	Permanent Soil Reinforcement Mat	SY
1660	Seeding and Mulching	ACR

1661	Seed - Repair Seeding	LB
1661	Fertilizer - Repair Seeding	TON
1662	Seed - Supplemental Seeding	LB
1665	Fertilizer Topdressing	TON
SP	Safety/Highly Visible Fencing	LF
SP	Response for Erosion Control	EA

Construction Methods

Provide an approved subcontractor who performs an erosion control action as described in the NPDES Inspection Form SPPP30. Each erosion control action may include one or more of the above work items.

Measurement and Payment

Response for Erosion Control will be measured and paid for by counting the actual number of times the subcontractor moves onto the project, including borrow and waste sites, and satisfactorily completes an erosion control action described in Form 1675. The provisions of Article 104-5 of the *Standard Specifications* will not apply to this item of work.

Payment will be made under:

Pay Item

Response for Erosion Control

Pay Unit

Each

303(d) IMPAIRED WATERS LIST:

Muddy Creek, which has been identified on the 303(d) list of impaired waters as impaired for sedimentation and/or turbidity, is within one mile of the project and receives drainage from the project. The Contractor shall adhere to all conditions and/or regulations required for impacts to these waters.

ENVIRONMENTALLY SENSITIVE AREAS:

Description

This project is located in an *Environmentally Sensitive Area*. This designation requires special procedures to be used for clearing and grubbing, temporary stream crossings, and grading operations within the Environmentally Sensitive Areas identified on the plans and as designated by the Engineer. This also requires special procedures to be used for seeding and mulching and staged seeding within the project.

The Environmentally Sensitive Area shall be defined as a 50-foot buffer zone on both sides of the stream or depression measured from top of streambank or center of depression.

Construction Methods

(A) Clearing and Grubbing

In areas identified as Environmentally Sensitive Areas, the Contractor may perform clearing operations, but not grubbing operations until immediately prior to beginning grading operations as described in Article 200-1 of the *Standard Specifications*. Only clearing operations (not grubbing) shall be allowed in this buffer zone until immediately prior to beginning grading operations. Erosion control devices shall be installed immediately following the clearing operation.

(B) Grading

Once grading operations begin in identified Environmentally Sensitive Areas, work shall progress in a continuous manner until complete. All construction within these areas shall progress in a continuous manner such that each phase is complete and areas are permanently stabilized prior to beginning of next phase. Failure on the part of the Contractor to complete any phase of construction in a continuous manner in Environmentally Sensitive Areas will be just cause for the Engineer to direct the suspension of work in accordance with Article 108-7 of the *Standard Specifications*.

(C) Temporary Stream Crossings

Any crossing of streams within the limits of this project shall be accomplished in accordance with the requirements of Subarticle 107-12 of the *Standard Specifications*.

(D) Seeding and Mulching

Seeding and mulching shall be performed in accordance with Section 1660 of the *Standard Specifications* and vegetative cover sufficient to restrain erosion shall be installed immediately following grade establishment.

Seeding and mulching shall be performed on the areas disturbed by construction immediately following final grade establishment. No appreciable time shall lapse into the contract time without stabilization of slopes, ditches and other areas within the Environmentally Sensitive Areas.

(E) Stage Seeding

The work covered by this section shall consist of the establishment of a vegetative cover on cut and fill slopes as grading progresses. Seeding and mulching shall be done in stages on cut and fill slopes that are greater than 20 feet in height measured along the slope, or greater than 2 acres in area. Each stage shall not exceed the limits stated above.

Additional payments will not be made for the requirements of this section, as the cost for this work shall be included in the contract unit prices for the work involved.

MINIMIZE REMOVAL OF VEGETATION:

The Contractor shall minimize removal of vegetation within project limits to the maximum extent practicable. Vegetation along stream banks and adjacent to other jurisdictional resources outside the construction limits shall only be removed upon approval of Engineer. No additional payment will be made for this minimization work.

STOCKPILE AREAS:

The Contractor shall install and maintain erosion control devices sufficient to contain sediment around any erodible material stockpile areas as directed.

ACCESS AND HAUL ROADS:

At the end of each working day, the Contractor shall install or re-establish temporary diversions or earth berms across access/haul roads to direct runoff into sediment devices. Silt fence sections that are temporarily removed shall be reinstalled across access/haul roads at the end of each working day.

WASTE AND BORROW SOURCES:

Payment for temporary erosion control measures, except those made necessary by the Contractor's own negligence or for his own convenience, will be paid for at the appropriate contract unit price for the devices or measures utilized in borrow sources and waste areas.

No additional payment will be made for erosion control devices or permanent seeding and mulching in any commercial borrow or waste pit. All erosion and sediment control practices that may be required on a commercial borrow or waste site will be done at the Contractor's expense.

All offsite Staging Areas, Borrow and Waste sites shall be in accordance with "Borrow and Waste Site Reclamation Procedures for Contracted Projects" located at:

http://www.ncdot.gov/doh/operations/dp_chief_eng/roadside/fieldops/downloads/Files/ContractedReclamationProcedures.pdf

All forms and documents referenced in the "Borrow and Waste Site Reclamation Procedures for Contracted Projects" shall be included with the reclamation plans for offsite staging areas, and borrow and waste sites.

TEMPORARY DIVERSION:

This work consists of installation, maintenance, and cleanout of *Temporary Diversions* in accordance with Section 1630 of the *Standard Specifications*. The quantity of excavation for

installation and cleanout will be measured and paid for as *Silt Excavation* in accordance with Article 1630-3 of the *Standard Specifications*.

CLEAN WATER DIVERSION:

Description

This work consists of installing, maintaining, and removing any and all material required for the construction of clean water diversions. The clean water diversions shall be used to direct water flowing from offsite around/away from specific area(s) of construction.

Materials

Refer to Division 10

Item	Section
Geotextile for Soil Stabilization, Type 4	1056

Construction Methods

The Contractor shall install the clean water diversions in accordance with the details in the plans and at locations indicated in the plans, and as directed. Upon installation, the excavated material shall be immediately stabilized as provided in Section 1620 of the *Standard Specifications*. Other stabilization methods may be utilized with prior approval from the Engineer.

Line clean water diversion with geotextile unrolled in the direction of flow and lay smoothly but loosely on soil surface without creases. Bury top of slope geotextile edge in a trench at least 5" deep and tamp securely. Make vertical overlaps a minimum of 18" with upstream geotextile overlapping the downstream geotextile.

Secure geotextile with eleven gauge wire staples shaped into a *u* shape with a length of not less than 6" and a throat not less than 1" in width. Place staples along outer edges and throughout the geotextile a maximum of 3 ft. horizontally and vertically.

Measurement and Payment

Silt Excavation will be measured and paid for in accordance with Article 1630-4 of the *Standard Specifications*.

Geotextile for Soil Stabilization will be measured and paid for in accordance with Article 270-4 of the *Standard Specifications*.

Stabilization of the excavated material will be paid for as *Temporary Seeding* as provided in Section 1620 of the *Standard Specifications*.

Such price and payment shall be considered full compensation for all work covered by this section including all materials, construction, maintenance, and removal of the clean water diversions.

SAFETY FENCE AND JURISDICTIONAL FLAGGING:

Description

Safety Fence shall consist of furnishing materials, installing and maintaining polyethylene or polypropylene fence along the outside riparian buffer, wetland, or water boundary, or other boundaries located within the construction corridor to mark the areas that have been approved to infringe within the buffer, wetland, endangered vegetation, culturally sensitive areas or water. The fence shall be installed prior to any land disturbing activities.

Interior boundaries for jurisdictional areas noted above shall be delineated by stakes and highly visible flagging.

Jurisdictional boundaries at staging areas, waste sites, or borrow pits, whether considered outside or interior boundaries shall be delineated by stakes and highly visible flagging.

Materials

(A) Safety Fencing

Polyethylene or polypropylene fence shall be a highly visible preconstructed safety fence approved by the Engineer. The fence material shall have an ultraviolet coating.

Either wood posts or steel posts may be used. Wood posts shall be hardwood with a wedge or pencil tip at one end, and shall be at least 5 ft. in length with a minimum nominal 2" x 2" cross section. Steel posts shall be at least 5 ft. in length, and have a minimum weight of 0.85 lb/ft of length.

(B) Boundary Flagging

Wooden stakes shall be 4 feet in length with a minimum nominal 3/4" x 1-3/4" cross section. The flagging shall be at least 1" in width. The flagging material shall be vinyl and shall be orange in color and highly visible.

Construction Methods

No additional clearing and grubbing is anticipated for the installation of this fence. The fence shall be erected to conform to the general contour of the ground.

(A) Safety Fencing

Posts shall be set at a maximum spacing of 10 ft., maintained in a vertical position and hand set or set with a post driver. Posts shall be installed a minimum of 2 ft. into the ground. If hand set, all backfill material shall be thoroughly tamped. Wood posts may be sharpened to a dull point if power driven. Posts damaged by power driving shall be removed and replaced prior to final acceptance. The tops of all wood posts shall be cut at a 30-degree angle. The wood posts may, at the option of the Contractor, be cut at this angle either before or after the posts are erected.

The fence geotextile shall be attached to the wood posts with one 2" galvanized wire staple across each cable or to the steel posts with wire or other acceptable means.

Place construction stakes to establish the location of the safety fence in accordance with Article 105-9 or Article 801-1 of the *Standard Specifications*. No direct pay will be made for the staking of the safety fence. All stakeouts for safety fence shall be considered incidental to the work being paid for as "Construction Surveying", except that where there is no pay item for construction surveying, all safety fence stakeout will be performed by state forces.

The Contractor shall be required to maintain the safety fence in a satisfactory condition for the duration of the project as determined by the Engineer.

(B) Boundary Flagging

Boundary flagging delineation of interior boundaries shall consist of wooden stakes on 25 feet maximum intervals with highly visible orange flagging attached. Stakes shall be installed a minimum of 6" into the ground. Interior boundaries may be staked on a tangent that runs parallel to buffer but must not encroach on the buffer at any location. Interior boundaries of hand clearing shall be identified with a different colored flagging to distinguish it from mechanized clearing.

Boundary flagging delineation of interior boundaries will be placed in accordance with Article 105-9 or Article 801-1 of the *Standard Specifications*. No direct pay will be made for delineation of the interior boundaries. This delineation will be considered incidental to the work being paid for as *Construction Surveying*, except that where there is no pay item or construction surveying the cost of boundary flagging delineation shall be included in the unit prices bid for the various items in the contract. Installation for delineation of all jurisdictional boundaries at staging areas, waste sites, or borrow pits shall consist of wooden stakes on 25 feet maximum intervals with highly visible orange flagging attached. Stakes shall be installed a minimum of 6" into the ground. Additional flagging may be placed on overhanging vegetation to enhance visibility but does not substitute for installation of stakes.

Installation of boundary flagging for delineation of all jurisdictional boundaries at staging areas, waste sites, or borrow pits shall be performed in accordance with Subarticle 230-4(B)(5) or Subarticle 802-2(F) of the *Standard Specifications*. No direct pay will be made for this delineation, as the cost of same shall be included in the unit prices bid for the various items in the contract.

The Contractor shall be required to maintain alternative stakes and highly visible flagging in a satisfactory condition for the duration of the project as determined by the Engineer.

Measurement and Payment

Safety Fence will be measured and paid as the actual number of linear feet of polyethylene or polypropylene fence installed in place and accepted. Such payment will be full compensation including but not limited to furnishing and installing fence geotextile with necessary posts and post bracing, staples, tie wires, tools, equipment and incidentals necessary to complete this work.

Payment will be made under:

Pay Item	Pay Unit
Safety Fence	Linear Foot

PERMANENT SOIL REINFORCEMENT MAT:

Description

This work consists of furnishing and placing *Permanent Soil Reinforcement Mat*, of the type specified, over previously prepared areas as directed.

Materials

The product shall be a permanent erosion control reinforcement mat and shall be constructed of synthetic or a combination of coconut and synthetic fibers evenly distributed throughout the mat between a bottom UV stabilized netting and a heavy duty UV stabilized top net. The matting shall be stitched together with UV stabilized polypropylene thread to form a permanent three-dimensional structure. The mat shall have the following minimum physical properties:

Property	Test Method	Value	Unit
Light Penetration	ASTM D6567	9	%
Thickness	ASTM D6525	0.40	in
Mass Per Unit Area	ASTM D6566	0.55	lb/sy
Tensile Strength	ASTM D6818	385	lb/ft
Elongation (Maximum)	ASTM D6818	49	%
Resiliency	ASTM D1777	>70	%
UV Stability *	ASTM D4355	≥80	%
Porosity (Permanent Net)	ECTC Guidelines	≥85	%
Maximum Permissible Shear Stress (Vegetated)	Performance Bench Test	≥8.0	lb/ft ²
Maximum Allowable Velocity (Vegetated)	Performance Bench Test	≥16.0	ft/s

*ASTM D1682 Tensile Strength and % strength retention of material after 1000 hours of exposure.

Submit a certification (Type 1, 2, or 3) from the manufacturer showing:

- (A) the chemical and physical properties of the mat used, and
- (B) conformance of the mat with this specification.

Construction Methods

Matting shall be installed in accordance with Subarticle 1631-3(B) of the *Standard Specifications*.

All areas to be protected with the mat shall be brought to final grade and seeded in accordance with Section 1660 of the *Standard Specifications*. The surface of the soil shall be smooth, firm, stable and free of rocks, clods, roots or other obstructions that would prevent the mat from lying in direct contact with the soil surface. Areas where the mat is to be placed will not need to be mulched.

Measurement and Payment

Permanent Soil Reinforcement Mat will be measured and paid for as the actual number of square yards measured along the surface of the ground over which Permanent Soil Reinforcement Mat is installed and accepted. Overlaps will not be included in the measurement, and will be considered as incidental to the work. Such payment shall be full compensation for furnishing and installing the mat, including overlaps, and for all required maintenance.

Payment will be made under:

Pay Item	Pay Unit
Permanent Soil Reinforcement Mat	Square Yard

SKIMMER BASIN WITH BAFFLES:

Description

Provide a skimmer basin to remove sediment from construction site runoff at locations shown in the erosion control plans. See the Skimmer Basin with Baffles Detail sheet provided in the erosion control plans. Work includes constructing sediment basin, installation of temporary slope drain pipe and coir fiber baffles, furnishing, installation and cleanout of skimmer, providing and placing stone pad on bottom of basin underneath skimmer device, providing and placing a geotextile spillway liner, providing coir fiber mat stabilization for the skimmer outlet, disposing of excess materials, removing temporary slope drain, coir fiber baffles, geotextile liner and skimmer device, backfilling basin area with suitable material and providing proper drainage when basin area is abandoned.

Materials

Item	Section
Stone for Erosion Control, Class B	1042
Geotextile for Soil Stabilization, Type 4	1056
Fertilizer for Temporary Seeding	1060-2
Seed for Temporary Seeding	1060-4
Seeding and Mulching	1060-4
Matting for Erosion Control	1060-8
Staples	1060-8
Coir Fiber Mat	1060-14
Temporary Slope Drain	1622-2
Coir Fiber Baffle	1640

Provide appropriately sized and approved skimmer device.

Provide Schedule 40 PVC pipe with a length of 6 ft. to attach to the skimmer and the coupling connection to serve as the arm pipe. For skimmer sizes of 2.5 in. and smaller, the arm pipe diameter shall be 1.5 inches. For skimmer sizes of 3 in. and larger, refer to manufacturer recommendation.

Provide 4" diameter Schedule 40 PVC pipe to attach to coupling connection of skimmer to serve as the barrel pipe through the earthen dam.

Anchors: Staples, stakes, or reinforcement bars shall be used as anchors.

Wooden Stakes:

Provide hardwood stakes 12" - 24" long with a 2" x 2" nominal square cross section. One end of the stake must be sharpened or beveled to facilitate driving through the coir fiber mat and down into the underlying soil. The other end of the stake needs to have a 1" - 2" long head at the top with a 1" - 2" notch following to catch and secure the coir fiber mat.

Steel Reinforcement Bars:

Provide uncoated #10 steel reinforcement bars 24" nominal length. The bars shall have a 4" diameter bend at one end with a 4" straight section at the tip to catch and secure the coir fiber mat.

Staples:

Provide staples made of 0.125" diameter new steel wire formed into a *u* shape not less than 12" in length with a throat of 1" in width.

Construction Methods

Excavate basin according to the erosion control plans with basin surface free of obstructions, debris, and pockets of low-density material. Install temporary slope drain pipe and construct the primary spillway according to the Skimmer Basin with Baffles Detail sheet in the erosion control plans. Temporary slope drain pipe at inlet of basin may be replaced by geotextile as directed. Construct the coir fiber baffles according to *Roadway Standard Drawings* No. 1640.01 and Section 1640 of the *Standard Specifications*.

Install skimmer device according to manufacturer recommendations. Install 4" Schedule 40 PVC pipe into dam on the lower side of basin 1 ft. from the bottom of the basin and according to the detail, and extend the pipe so the basin will drain. Attach a 6 ft. arm pipe to the coupling connection and skimmer according to manufacturer recommendations. The coupling shall be rigid and non-buoyant and not exceed a diameter of 4" and 12" in length. Attach the rope included with the skimmer to the tee between the vent socket and the tube inlet, and the other end to a wooden stake or metal post. Clean out skimmer device when it becomes clogged with sediment and/or debris and is unable to float at the top of water in skimmer basin. Take appropriate measures to avoid ice accumulation in the skimmer device. Construct a stone pad of Class B stone directly underneath the skimmer device at bottom of basin. The pad shall be a minimum of 12" in height, and shall have a minimum cross sectional area of 4 ft. by 4 ft.

Line primary spillway with geotextile unrolled in the direction of flow and lay smoothly but loosely on soil surface without creases. Bury edges of geotextile in a trench at least 5" deep and tamp firmly. If geotextile for the primary spillway is not one continuous piece of material, make horizontal overlaps a minimum of 18" with upstream geotextile overlapping the downstream geotextile. Secure geotextile with eleven gauge wire staples shaped into a *u* shape with a length of not less than 12" and a throat not less than 1" in width. Place staples along outer edges and throughout the geotextile a maximum of 3 ft. horizontally and vertically. Geotextile shall be placed to the bottom and across the entire width of the basin according to the Skimmer Basin with Baffles detail. Place sealant inside basin around barrel pipe on top of geotextile with a minimum width of 6 in.

At the skimmer outlet, provide a smooth soil surface free from stones, clods, or debris that will prevent contact of the coir fiber matting with the soil. Unroll the matting and apply without stretching such that it will lie smoothly but loosely on the soil surface. Wooden stakes, reinforcement bars, or staples may be used as anchors in accordance with the details in the plans and as directed. Place anchors across the matting at the ends approximately 1 ft. apart. Place anchors along the outer edges and down the center of the matting 3 ft. apart.

All bare side slope sections of the skimmer basin shall be seeded with a temporary or permanent seed mix as directed and in accordance with Articles 1620-3, 1620-4, 1620-5, 1660-4, 1660-5 and 1660-7 of the *Standard Specifications*. Straw or excelsior matting shall be installed on all bare side slope sections immediately upon the completion of seeding and in accordance with Article 1631-3 of the *Standard Specifications*.

Measurement and Payment

Silt Excavation will be measured and paid for in accordance with Article 1630-4 of the *Standard Specifications*, as calculated from the typical section throughout the length of the basin as shown on the final approved plans.

Geotextile for Soil Stabilization will be measured and paid for in accordance with Article 270-4 of the *Standard Specifications*.

Coir Fiber Baffles will be measured and paid for in accordance with Article 1640-4 of the *Standard Specifications*.

___" *Skimmer* will be measured in units of each. ___" *Skimmer* will be measured and paid for as the maximum number of each size skimmer acceptably installed and in use at any one time during the life of the project. Barrel and arm pipe, cleanout, relocation and reinstallation of ___" *Skimmer* is considered incidental to the measurement of the quantity of ___" *Skimmer* and no separate payment will be made. No separate payment shall be made if ___" *Skimmer*, barrel and/or arm pipe(s) are damaged by ice accumulation.

Coir Fiber Mat will be measured and paid for as the actual number of square yards measured along the surface of the ground over which coir fiber mat is installed and accepted.

Temporary Slope Drain will be measured and paid for in accordance with Article 1622-4 of the *Standard Specifications*.

Stone for Erosion Control, Class ___ will be measured and paid for in accordance with Article 1610-4 of the *Standard Specifications*.

Seeding and Mulching will be measured and paid for in accordance with Article 1660-8 of the *Standard Specifications*.

Seed for Temporary Seeding will be measured and paid for in accordance with Article 1620-6 of the *Standard Specifications*.

Fertilizer for Temporary Seeding will be measured and paid for in accordance with Article 1620-6 of the *Standard Specifications*.

Matting for Erosion Control will be measured and paid for in accordance with Article 1631-4 of the *Standard Specifications*.

No measurement will be made for other items or for over excavation or stockpiling.

Payment will be made under:

Pay Item	Pay Unit
___" Skimmer	Each
Coir Fiber Mat	Square Yard

TIERED SKIMMER BASIN WITH BAFFLES:

Description

Provide a tiered skimmer basin to remove sediment from construction site runoff at locations shown in the erosion control plans. See the Tiered Skimmer Basin Detail sheet provided in the erosion control plans. Tiered Skimmer Basins shall be installed in areas where topography creates a large elevation difference between the inlet and outlet of a single skimmer basin. Work includes constructing sediment basins, installation of coir fiber baffles, installation of temporary slope drain pipe, furnishing, installation and cleanout of skimmer, providing and placing stone pad on bottom of basin underneath skimmer device, providing and placing geotextile spillway liners, providing coir fiber mat stabilization for the skimmer outlet, disposing of excess materials, removing temporary slope drain pipe, coir fiber baffles, geotextile liner and skimmer device, backfilling basin area with suitable material and providing proper drainage when basin area is abandoned.

Materials

Item	Section
Stone for Erosion Control, Class B	1042
Geotextile for Soil Stabilization, Type 4	1056
Fertilizer for Temporary Seeding	1060-2
Seed for Temporary Seeding	1060-4
Seeding and Mulching	1060-4
Matting for Erosion Control	1060-8
Staples	1060-8
Coir Fiber Mat	1060-14
Temporary Slope Drain	1622-2
Coir Fiber Baffle	1640

Provide appropriately sized and approved skimmer device.

Provide Schedule 40 PVC pipe with a length of 6 ft. to attach to the skimmer and the coupling connection to serve as the arm pipe. For skimmer sizes of 2.5 in. and smaller, the arm pipe diameter shall be 1.5 inches. For skimmer sizes of 3 in. and larger, refer to manufacturer recommendation.

Provide 4" diameter Schedule 40 PVC pipe to attach to coupling connection of skimmer to serve as the barrel pipe through the earthen dam.

Anchors: Staples, stakes, or reinforcement bars shall be used as anchors.

Wooden Stakes:

Provide hardwood stakes 12"- 24" long with a 2" x 2" nominal square cross section. One end of the stake must be sharpened or beveled to facilitate driving through the coir fiber mat and down into the underlying soil. The other end of the stake needs to have a 1"- 2" long head at the top with a 1"- 2" notch following to catch and secure the coir fiber mat.

Steel Reinforcement Bars:

Provide uncoated #10 steel reinforcement bars 24" nominal length. The bars shall have a 4" diameter bend at one end with a 4" straight section at the tip to catch and secure the coir fiber mat.

Staples:

Provide staples made of 0.125" diameter new steel wire formed into a *u* shape not less than 12" in length with a throat of 1" in width.

Construction Methods

Excavate basins according to the erosion control plans with basin surface free of obstructions, debris, and pockets of low-density material. Install temporary slope drain pipe and construct the primary spillways according to the Tiered Skimmer Basin Detail sheet in the erosion control plans. Construct the coir fiber baffles according to *Roadway Standard Drawings* No. 1640.01 and Section 1640 of the *Standard Specifications*. Multiple upper basins, or Modified Silt Basins Type 'B' as labeled on the detail, may be required based on site conditions and as directed.

Install skimmer device according to manufacturer recommendations. Install 4" Schedule 40 PVC pipe into dam on the lower side of basin 1 ft. from the bottom of the basin and according to the detail, and extend the pipe so the basin will drain. Attach a 6 ft. arm pipe to the coupling connection and skimmer according to manufacturer recommendations. The coupling shall be rigid and non-buoyant and not exceed a diameter of 4" and 12" in length. Attach the rope included with the skimmer to the tee between the vent socket and the tube inlet, and the other end to a wooden stake or metal post. Clean out skimmer device when it becomes clogged with sediment and/or debris and is unable to float at the top of water in skimmer basin. Take appropriate measures to avoid ice accumulation in the skimmer device. Construct a stone pad of Class B stone directly underneath the skimmer device at bottom of basin. The pad shall be a minimum of 12" in height, and shall have a minimum cross sectional area of 4 ft. by 4 ft.

Line primary spillways with geotextile unrolled in the direction of flow and lay smoothly but loosely on soil surface without creases. Bury edges of geotextile in a trench at least 5" deep and tamp firmly. If geotextile for primary spillways is not one continuous piece of material, make horizontal overlaps a minimum of 18" with upstream geotextile overlapping the downstream geotextile. Secure geotextile with eleven gauge wire staples shaped into a *u* shape with a length

of not less than 12" and a throat not less than 1" in width. Place staples along outer edges and throughout the geotextile a maximum of 3 ft. horizontally and vertically. Geotextile shall be placed to the bottom and across the entire width of the basin according to the Tiered Skimmer Basin with Baffles detail.

At the skimmer outlet, provide a smooth soil surface free from stones, clods, or debris that will prevent contact of the coir fiber matting with the soil. Unroll the matting and apply without stretching such that it will lie smoothly but loosely on the soil surface. Wooden stakes, reinforcement bars, or staples may be used as anchors in accordance with the details in the plans and as directed. Place anchors across the matting at the ends approximately 1 ft. apart. Place anchors along the outer edges and down the center of the matting 3 ft. apart. Place sealant inside basin around barrel pipe on top of geotextile with a minimum width of 6 in.

All bare side slope sections of the skimmer basin shall be seeded with a temporary or permanent seed mix as directed and in accordance with Articles 1620-3, 1620-4, 1620-5, 1660-4, 1660-5 and 1660-7 of the *Standard Specifications*. Straw or excelsior matting shall be installed on all bare side slope sections immediately upon the completion of seeding and in accordance with Article 1631-3 of the *Standard Specifications*.

Measurement and Payment

Silt Excavation will be measured and paid for in accordance with Article 1630-4 of the *Standard Specifications*, as calculated from the typical section throughout the length of the basin as shown on the final approved plans.

Geotextile for Soil Stabilization will be measured and paid for in accordance with Article 270-4 of the *Standard Specifications*.

Coir Fiber Baffles will be measured and paid for in accordance with Article 1640-4 of the *Standard Specifications*.

___" *Skimmer* will be measured in units of each. ___" *Skimmer* will be measured and paid for as the maximum number of each size skimmer acceptably installed and in use at any one time during the life of the project. Barrel and arm pipe, cleanout, relocation and reinstallation of ___" *Skimmer* is considered incidental to the measurement of the quantity of ___" *Skimmer* and no separate payment will be made. No separate payment shall be made if ___" *Skimmer*, barrel and/or arm pipe(s) are damaged by ice accumulation.

Coir Fiber Mat will be measured and paid for as the actual number of square yards measured along the surface of the ground over which coir fiber mat is installed and accepted.

Temporary Slope Drain will be measured and paid for in accordance with Article 1622-4 of the *Standard Specifications*.

Stone for Erosion Control, Class ___ will be measured and paid for in accordance with Article 1610-4 of the *Standard Specifications*.

Seeding and Mulching will be measured and paid for in accordance with Article 1660-8 of the *Standard Specifications*.

Seed for Temporary Seeding will be measured and paid for in accordance with Article 1620-6 of the *Standard Specifications*.

Fertilizer for Temporary Seeding will be measured and paid for in accordance with Article 1620-6 of the *Standard Specifications*.

Matting for Erosion Control will be measured and paid for in accordance with Article 1631-4 of the *Standard Specifications*.

No measurement will be made for other items or for over excavation or stockpiling.

Payment will be made under:

Pay Item	Pay Unit
___" Skimmer	Each
Coir Fiber Mat	Square Yard

EARTHEN DAM WITH SKIMMER:

Description

Provide an earthen dam with a skimmer attached to a barrel pipe at the outlet of a proposed roadway ditch to remove sediment from construction site runoff at locations shown in the erosion control plans. See the Earthen Dam with Skimmer Detail sheet provided in the erosion control plans. Work includes constructing earthen dam, installation of coir fiber baffles, furnishing, installation and cleanout of skimmer, providing and placing stone pad on bottom of ditch underneath skimmer device, providing and placing geotextile spillway liner, providing coir fiber mat stabilization for the skimmer outlet, removing earthen dam, coir fiber baffles, geotextile liner and skimmer device, and disposing of excess materials.

Materials

Item	Section
Stone for Erosion Control, Class B	1042
Geotextile for Soil Stabilization, Type 4	1056
Staples	1060-8
Coir Fiber Mat	1060-14
Coir Fiber Baffle	1640

Provide appropriately sized and approved skimmer device.

Provide Schedule 40 PVC pipe with a length of 6 ft. to attach to the skimmer and the coupling connection to serve as the arm pipe. For skimmer sizes of 2.5 in. and smaller, the arm pipe

diameter shall be 1.5 inches. For skimmer sizes of 3 in. and larger, refer to manufacturer recommendation.

Provide 4" diameter Schedule 40 PVC pipe to attach to coupling connection of skimmer to serve as the barrel pipe through the earthen dam.

Anchors: Staples, stakes, or reinforcement bars shall be used as anchors.

Wooden Stakes:

Provide hardwood stakes 12" - 24" long with a 2" x 2" nominal square cross section. One end of the stake must be sharpened or beveled to facilitate driving through the coir fiber mat and down into the underlying soil. The other end of the stake needs to have a 1" - 2" long head at the top with a 1" - 2" notch following to catch and secure the coir fiber mat.

Steel Reinforcement Bars:

Provide uncoated #10 steel reinforcement bars 24" nominal length. The bars shall have a 4" diameter bend at one end with a 4" straight section at the tip to catch and secure the coir fiber mat.

Staples:

Provide staples made of 0.125" diameter new steel wire formed into a *u* shape not less than 12" in length with a throat of 1" in width.

Construction Methods

Excavate proposed ditch according to the roadway plans and cross sections with ditch surface free of obstructions, debris, and pockets of low-density material. Construct earthen dam and install the primary spillway according to the Earthen Dam with Skimmer Detail sheet in the erosion control plans. Construct the coir fiber baffles according to *Roadway Standard Drawings* No. 1640.01 and Section 1640 of the *Standard Specifications*. Accumulated silt behind the earthen dam and baffles shall be removed regularly and as directed.

Install skimmer device according to manufacturer recommendations. Install 4" Schedule 40 PVC pipe into dam on the lower side of basin 1 ft. from the bottom of the basin and according to the detail, and extend the pipe so the basin will drain. Attach a 6 ft. arm pipe to the coupling connection and skimmer according to manufacturer recommendations. The coupling shall be rigid and non-buoyant and not exceed a diameter of 4" and 12" in length. Attach the rope included with the skimmer to the tee between the vent socket and the tube inlet, and the other end to a wooden stake or metal post. Clean out skimmer device when it becomes clogged with sediment and/or debris and is unable to float at the top of water impounded in the ditch. Take appropriate measures to avoid ice accumulation in the skimmer device. Construct a stone pad of Class B stone directly underneath the skimmer device at bottom of ditch. The pad shall be a minimum of 12" in height, and shall have a minimum cross sectional area of 4 ft. by 4 ft.

Line primary spillway with geotextile unrolled in the direction of flow and lay smoothly but loosely on soil surface without creases. Bury edges of geotextile in a trench at least 5" deep and tamp firmly. If geotextile for the primary spillway is not one continuous piece of material, make horizontal overlaps a minimum of 18" with upstream geotextile overlapping the downstream geotextile. Secure geotextile with eleven gauge wire staples shaped into a *u* shape with a length of not less than 12" and a throat not less than 1" in width. Place staples along outer edges and throughout the geotextile a maximum of 3 ft. horizontally and vertically. Geotextile shall be placed to the bottom and across the entire width of the ditch according to the Earthen Dam with Skimmer Detail. Place sealant inside basin around barrel pipe on top of geotextile with a minimum width of 6 in.

At the skimmer outlet, provide a smooth soil surface free from stones, clods, or debris that will prevent contact of the coir fiber matting with the soil. Unroll the matting and apply without stretching such that it will lie smoothly but loosely on the soil surface. Wooden stakes, reinforcement bars, or staples may be used as anchors in accordance with the details in the plans and as directed. Place anchors across the matting at the ends approximately 1 ft. apart. Place anchors along the outer edges and down the center of the matting 3 ft. apart.

Measurement and Payment

The construction of the earthen dam will be paid for as *Borrow Excavation* as provided in Section 230 of the *Standard Specifications* or included in the lump sum price for grading.

Silt Excavation will be measured and paid for in accordance with Article 1630-4 of the *Standard Specifications*, as calculated from the typical section throughout the length of the ditch as shown on the final approved plans.

Geotextile for Soil Stabilization will be measured and paid for in accordance with Article 270-4 of the *Standard Specifications*.

Coir Fiber Baffles will be measured and paid for in accordance with Article 1640-4 of the *Standard Specifications*.

___" *Skimmer* will be measured in units of each. ___" *Skimmer* will be measured and paid for as the maximum number of each size skimmer acceptably installed and in use at any one time during the life of the project. Barrel and arm pipe, cleanout, relocation and reinstallation of ___" *Skimmer* is considered incidental to the measurement of the quantity of ___" *Skimmer* and no separate payment will be made. No separate payment shall be made if ___" Skimmer, barrel and/or arm pipe(s) are damaged by ice accumulation.

Coir Fiber Mat will be measured and paid for as the actual number of square yards measured along the surface of the ground over which coir fiber mat is installed and accepted.

Stone for Erosion Control, Class ___ will be measured and paid for in accordance with Article 1610-4 of the *Standard Specifications*.

No measurement will be made for other items or for over excavation or stockpiling.

Payment will be made under:

Pay Item	Pay Unit
__" Skimmer	Each
Coir Fiber Mat	Square Yard

COIR FIBER WATTLES WITH POLYACRYLAMIDE (PAM):

Description

Coir Fiber Wattles are tubular products consisting of coir fibers (coconut fibers) encased in coir fiber netting. Coir Fiber Wattles are used on slopes or channels to intercept runoff and act as a velocity break. Coir Fiber Wattles are to be placed at locations shown on the plans or as directed. Installation shall follow the detail provided in the plans and as directed. Work includes furnishing materials, installation of coir fiber wattles, matting installation, PAM application, and removing wattles.

Materials

Coir Fiber Wattle shall meet the following specifications:

100% Coir (Coconut) Fibers	
Minimum Diameter	12 in.
Minimum Density	3.5 lb/ft ³ +/- 10%
Net Material	Coir Fiber
Net Openings	2 in. x 2 in.
Net Strength	90 lbs.
Minimum Weight	2.6 lbs./ft. +/- 10%

Anchors: Stakes shall be used as anchors.

Wooden Stakes:

Provide hardwood stakes a minimum of 2-ft. long with a 2 in. x 2 in. nominal square cross section. One end of the stake must be sharpened or beveled to facilitate driving down into the underlying soil.

Matting shall meet the requirements of Article 1060-8 of the *Standard Specifications*, or shall meet specifications provided elsewhere in this contract.

Provide staples made of 0.125" diameter new steel wire formed into a *u* shape not less than 12" in length with a throat of 1" in width.

Polyacrylamide (PAM) shall be applied in powder form and shall be anionic or neutrally charged. Soil samples shall be obtained in areas where the wattles will be placed, and from offsite material used to construct the roadway, and analyzed for the appropriate PAM flocculant to be utilized with each wattle. The PAM product used shall be listed on the North Carolina Department of Environment and Natural Resources (NCDENR) Division of Water Quality (DWQ) web site as an approved PAM product for use in North Carolina.

Construction Methods

Coir Fiber Wattles shall be secured to the soil by wire staples approximately every 1 linear foot and at the end of each section of wattle. A minimum of 4 stakes shall be installed on the downstream side of the wattle with a maximum spacing of 2 linear feet along the wattle, and according to the detail. Install a minimum of 2 stakes on the upstream side of the wattle according to the detail provided in the plans. Stakes shall be driven into the ground a minimum of 10 in. with no more than 2 in. projecting from the top of the wattle. Drive stakes at an angle according to the detail provided in the plans.

Only install coir fiber wattle(s) to a height in ditch so flow will not wash around wattle and scour ditch slopes and according to the detail provided in the plans and as directed. Overlap adjoining sections of wattles a minimum of 6 in.

Installation of matting shall be in accordance with the detail provided in the plans, and in accordance with Article 1631-3 of the *Standard Specifications*, or in accordance with specifications provided elsewhere in this contract.

Apply PAM over the lower center portion of the coir fiber wattle where the water is going to flow over at a rate of 2 ounces per wattle, and 1 ounce of PAM on matting on each side of the wattle. PAM applications shall be done during construction activities after every rainfall event that is equal to or exceeds 0.50 in.

The Contractor shall maintain the coir fiber wattles until the project is accepted or until the wattles are removed, and shall remove and dispose of silt accumulations at the wattles when so directed in accordance with the requirements of Section 1630 of the *Standard Specifications*.

Measurement and Payment

Coir Fiber Wattles will be measured and paid for by the actual number of linear feet of wattles which are installed and accepted. Such price and payment will be full compensation for all work covered by this section, including, but not limited to, furnishing all materials, labor, equipment and incidentals necessary to install the *Coir Fiber Wattles*.

Matting will be measured and paid for in accordance with Article 1631-4 of the *Standard Specifications*, or in accordance with specifications provided elsewhere in this contract.

Polyacrylamide(PAM) will be measured and paid for by the actual weight in pounds of PAM applied to the coir fiber wattles. Such price and payment will be full compensation for all work

covered by this section, including, but not limited to, furnishing all materials, labor, equipment and incidentals necessary to apply the *Polyacrylamide(PAM)*.

Payment will be made under:

Pay Item	Pay Unit
Polyacrylamide(PAM)	Pound
Coir Fiber Wattle	Linear Foot

TEMPORARY ROCK SILT CHECK TYPE A WITH EXCELSIOR MATTING AND POLYACRYLAMIDE (PAM):

Description

Temporary Rock Silt Checks Type A with Excelsior Matting and Polyacrylamide (PAM) are devices utilized in temporary and permanent ditches to reduce runoff velocity and incorporate PAM into the construction runoff to increase settling of sediment particles and reduce turbidity of runoff. Temporary Rock Silt Checks Type A with Excelsior Matting and PAM are to be placed at locations shown on the plans or as directed. Installation shall follow the detail provided in the plans and as directed. Work includes furnishing materials, installation of Temporary Rock Silt Checks Type A, matting installation, PAM application, and removing Temporary Rock Silt Checks Type A with Excelsior Matting and PAM.

Materials

Structural stone shall be class B stone that meets the requirements of Section 1042 of the *Standard Specifications* for Stone for Erosion Control, Class B.

Sediment control stone shall be #5 or #57 stone, which meets the requirements of Section 1005 of the *Standard Specifications* for these stone sizes.

Matting shall meet the requirements of Excelsior Matting in Subarticle 1060-8(B) of the *Standard Specifications*, or shall meet specifications provided elsewhere in this contract.

Polyacrylamide (PAM) shall be applied in powder form and shall be anionic or neutrally charged. Soil samples shall be obtained in areas where the Temporary Rock Silt Checks Type A with Excelsior Matting and PAM will be placed, and from offsite material used to construct the roadway, and analyzed for the appropriate PAM flocculant to be utilized with each Temporary Rock Silt Check Type A. The PAM product used shall be listed on the North Carolina Department of Environment and Natural Resources (NCDENR) Division of Water Quality (DWQ) web site as an approved PAM product for use in North Carolina.

Construction Methods

Temporary Rock Silt Checks Type A shall be installed in accordance with Subarticle 1633-3(A) of the *Standard Specifications*, Roadway Standard Drawing No. 1633.01 and the detail provided in the plans.

Installation of matting shall be in accordance with the detail provided in the plans, and anchored by placing Class B stone on top of the matting at the upper and lower ends.

Apply PAM at a rate of 4 ounces over the center portion of the Temporary Rock Silt Checks Type A and matting where the water is going to flow over. PAM applications shall be done during construction activities and after every rainfall event that is equal to or exceeds 0.50 in.

The Contractor shall maintain the Temporary Rock Silt Checks Type A with Excelsior Matting and PAM until the project is accepted or until the Temporary Rock Silt Checks Type A with Excelsior Matting and PAM are removed, and shall remove and dispose of silt accumulations at the Temporary Rock Silt Checks Type A with Excelsior Matting and PAM when so directed in accordance with the requirements of Section 1630 of the *Standard Specifications*.

Measurement and Payment

Temporary Rock Silt Checks Type A will be measured and paid for in accordance with Article 1633-5 of the *Standard Specifications*, or in accordance with specifications provided elsewhere in this contract.

Matting will be measured and paid for in accordance with Article 1631-4 of the *Standard Specifications*, or in accordance with specifications provided elsewhere in this contract.

Polyacrylamide(PAM) will be measured and paid for by the actual weight in pounds of PAM applied to the Temporary Rock Silt Checks Type A. Such price and payment will be full compensation for all work covered by this section, including, but not limited to, furnishing all materials, labor, equipment and incidentals necessary to apply the *Polyacrylamide(PAM)*.

Payment will be made under:

Pay Item	Pay Unit
Polyacrylamide(PAM)	Pound

CONCRETE WASHOUT STRUCTURE: (12-01-15)

Description

Concrete washout structures are enclosures above or below grade to contain concrete waste water and associated concrete mix from washing out ready-mix trucks, drums, pumps, or other equipment. Concrete washouts must collect and retain all the concrete washout water and solids,

so that this material does not migrate to surface waters or into the ground water. These enclosures are not intended for concrete waste not associated with wash out operations.

The concrete washout structure may include constructed devices above or below ground and or commercially available devices designed specifically to capture concrete waste water.

Materials

Item	Section
Temporary Silt Fence	1605

Safety Fence shall meet the specifications as provided elsewhere in this contract.

Geomembrane basin liner shall meet the following minimum physical properties for low permeability; it shall consist of a polypropylene or polyethylene 10 mil think geomembrane. If the minimum setback dimensions can be achieved the liner is not required. (5 feet above groundwater, 50 feet from top of bank of perennial stream, other surface water body, or wetland.)

Construction Methods

Build an enclosed earthen berm or excavate to form an enclosure in accordance with the details and as directed.

Install temporary silt fence around the perimeter of the enclosure in accordance with the details and as directed if structure is not located in an area where existing erosion and sedimentation control devices are capable to containing any loss of sediment.

Post a sign with the words "Concrete Washout" in close proximity of the concrete washout area, so it is clearly visible to site personnel.

The construction details for the above grade and below grade concrete washout structures can be found on the following web page link:

http://www.ncdot.gov/doh/operations/dp_chief_eng/roadside/soil_water/details/

[Alternate details for accommodating concrete washout may be submitted for review and approval.](#)

[The alternate details shall include the method used to retain and dispose of the concrete waste water within the project limits and in accordance with the minimum setback requirements.](#) (5 feet above groundwater, 50 feet from top of bank of perennial stream, other surface water body, or wetland.)

Maintenance and Removal

Maintain the concrete washout structure(s) to provide adequate holding capacity plus a minimum freeboard of 12 inches. Remove and dispose of hardened concrete and return the structure to a functional condition after reaching 75% capacity.

Inspect concrete washout structures for damage and maintain for effectiveness.

Remove the concrete washout structures and sign upon project completion. Grade the earth material to match the existing contours and permanently seed and mulch area.

Measurement and Payment

Concrete Washout Structure will be paid for per each enclosure installed in accordance with the details. If alternate details are approved then those details will also be paid for per each approved and installed device.

Temporary Silt Fence will be measured and paid for in accordance with Article 1605-5 of the *Standard Specifications*.

No measurement will be made for other items or for over excavation or stockpiling.

Payment will be made under:

Pay Item	Pay Unit
Concrete Washout Structure	Each

IMPERVIOUS DIKE:

Description

This work consists of furnishing, installing, maintaining, and removing an *Impervious Dike* for the purpose of diverting normal stream flow around the construction site. The Contractor shall construct an impervious dike in such a manner approved by the Engineer. The impervious dike shall not permit seepage of water into the construction site or contribute to siltation of the stream. The impervious dike shall be constructed of an acceptable material in the locations noted on the plans or as directed.

Materials

Acceptable materials shall include but not be limited to sheet piles, sandbags, and/or the placement of an acceptable size stone lined with polypropylene or other impervious geotextile.

Earth material shall not be used to construct an impervious dike when it is in direct contact with the stream unless vegetation can be established before contact with the stream takes place.

Measurement and Payment

Impervious Dike will be measured and paid as the actual number of linear feet of impervious dike(s) constructed, measured in place from end to end of each separate installation that has been completed and accepted. Such price and payment will be full compensation for all work including but not limited to furnishing materials, construction, maintenance, and removal of the impervious dike.

Payment will be made under:

Pay Item	Pay Unit
Impervious Dike	Linear Foot

COIR FIBER MAT:**Description**

Furnish material, install and maintain coir fiber mat in locations shown on the plans or in locations as directed. Work includes providing all materials, excavating and backfilling, and placing and securing coir fiber mat with stakes, steel reinforcement bars or staples as directed.

Materials

Item	Section
Coir Fiber Mat	1060-14

Anchors: Stakes, reinforcement bars, or staples shall be used as anchors.

Wooden Stakes:

Provide hardwood stakes 12"- 24" long with a 2" x 2" nominal square cross section. One end of the stake must be sharpened or beveled to facilitate driving through the coir fiber mat and down into the underlying soil. The other end of the stake needs to have a 1"- 2" long head at the top with a 1"- 2" notch following to catch and secure the coir fiber mat.

Steel Reinforcement Bars:

Provide uncoated #10 steel reinforcement bars 24" nominal length. The bars shall have a 4" diameter bend at one end with a 4" straight section at the tip to catch and secure the coir fiber mat.

Staples:

Provide staples made of 0.125" diameter new steel wire formed into a *u* shape not less than 12" in length with a throat of 1" in width.

Construction Methods

Place the coir fiber mat immediately upon final grading. Provide a smooth soil surface free from stones, clods, or debris that will prevent the contact of the mat with the soil. Unroll the mat and apply without stretching such that it will lie smoothly but loosely on the soil surface.

For stream relocation applications, take care to preserve the required line, grade, and cross section of the area covered. Bury the top slope end of each piece of mat in a narrow trench at least 6 in. deep and tamp firmly. Where one roll of matting ends and a second roll begins, overlap the end of the upper roll over the buried end of the second roll so there is a 6 in. overlap. Construct check trenches at least 12 in. deep every 50 ft. longitudinally along the edges of the mat or as directed. Fold over and bury mat to the full depth of the trench, close and tamp firmly. Overlap mat at least 6 in. where 2 or more widths of mat are installed side by side.

Place anchors across the mat at the ends approximately 1 ft. apart. Place anchors along the outer edges and down the center of the mat 3 ft. apart.

Adjustments in the trenching or anchoring requirements to fit individual site conditions may be required.

Measurement and Payment

Coir Fiber Mat will be measured and paid for as the actual number of square yards measured along the surface of the ground over which coir fiber mat is installed and accepted.

No measurement will be made for anchor items.

Payment will be made under:

Pay Item	Pay Unit
Coir Fiber Mat	Square Yard

STREAM MITIGATION:

All Stream Mitigation Work must be performed by Contractor on NCDOT's Approved Pre-Qualified List for Stream Restoration and Construction (Work Code 1601).

STREAM CHANNEL RELOCATION LIMITATIONS:

The following sequence of construction shall be followed in the areas designated on the plans as stream relocations. Failure on the part of the Contractor to follow this sequence, and complete each step prior to proceeding in this area as specified, will be just cause for the Engineer to direct the suspension of work in accordance with Article 108-7 of the *Standard Specifications*.

- (A) Clear, but do not grub area within the Environmentally Sensitive Area on the existing stream to be relocated.
- (B) Construct and stabilize, with vegetation or erosion control materials sufficient to restrain erosion, the proposed stream channel relocation as shown on the plans.
- (C) Divert water into newly constructed channel only after it has been stabilized and approved.
- (D) Begin grubbing and/or grading within the Environmentally Sensitive Area of the existing stream.

The Contractor shall perform seeding and mulching and install erosion control matting to all cut/fill slopes adjacent to stream relocations in accordance with the contract.

The above requirements apply to the stream channels being constructed at the following stations:

Approx. -L- Sta. 72+00 to 88+50

STREAMBANK REFORESTATION:

Description

Streambank Reforestation will be planted in areas designated on the plans and as directed. See the Streambank Reforestation Detail Sheets.

The entire *Streambank Reforestation* operation shall comply with the requirements of Section 1670 of the *Standard Specifications*.

Materials

Item	Section
Coir Fiber Mat	1060-14

Live Stakes:

Type I Streambank Reforestation shall be live stakes, planted along both streambanks. Live stakes shall be ½" - 2" in diameter. Stakes shall also be 2 ft. - 3 ft. in length.

Live staking plant material shall consist of a random mix made up of 50% Black Willow (*Salix nigra*) and 50% Silky Dogwood (*Cornus amomum*). Other species may be substituted upon approval of the Engineer. All plant material shall be harvested locally (within the same physiographic ecoregion and plant hardiness zone) or purchased from a local nursery, with the approval of the Engineer. All live stakes shall be dormant at time of acquisition and planting.

Staples, stakes, or reinforcement bars shall be used as anchors and shall meet the following requirements:

Wooden Stakes:

Provide hardwood stakes 12"- 24" long with a 2" x 2" nominal square cross section. One end of the stake must be sharpened or beveled to facilitate driving through the coir fiber mat and down into the underlying soil. The other end of the stake needs to have a 1"- 2" long head at the top with a 1"- 2" notch following to catch and secure the coir fiber mat.

Steel Reinforcement Bars:

Provide uncoated #10 steel reinforcement bars 24" nominal length. The bars shall have a 4" diameter bend at one end with a 4" straight section at the tip to catch and secure the coir fiber mat.

Staples:

Provide staples made of 0.125" diameter new steel wire formed into a *u* shape not less than 12" in length with a throat of 1" in width.

Bare Root Seedlings:

Type II Streambank Reforestation shall be bare root seedlings 12"-18" tall.

Construction Methods

Coir fiber matting shall be installed on the streambanks where live staking is to be planted as shown on the Streambank Reforestation Detail Sheets and in locations as directed. Work includes providing all materials, excavating and backfilling, and placing and securing coir fiber mat.

Provide a smooth soil surface free from stones, clods, or debris that will prevent the contact of the matting with the soil. Place the matting immediately upon final grading and permanent seeding. Take care to preserve the required line, grade, and cross section of the area covered.

Unroll the matting and apply without stretching such that it will lie smoothly but loosely on the soil surface. Bury the top slope end of each piece of matting in a narrow trench at least 6" deep and tamp firmly. Where one roll of matting ends and a second roll begins, overlap the end of the upper roll over the buried end of the second roll so there is a 6" overlap. Construct check trenches at least 12" deep every 50 ft. longitudinally along the edges of the matting, or as directed. Fold over and bury matting to the full depth of the trench, close and tamp firmly. Overlap matting at least 6" where 2 or more widths of matting are installed side by side.

Wooden stakes, reinforcement bars, or staples may be used as anchors in accordance with the Streambank Reforestation Detail Sheets and as directed. Place anchors across the matting at ends, junctions, and check trenches approximately 1 ft. apart. Place anchors down the center of each strip of matting 3 ft. apart. Place anchors along all lapped edges 1 ft. apart. Refer to the

Streambank Reforestation Detail Sheets for anchoring pattern. The Engineer may require adjustments in the trenching or anchoring requirements to fit individual site conditions.

During preparation of the live stakes, the basal ends shall be cleanly cut at an angle to facilitate easy insertion into the soil, while the tops shall be cut square or blunt for tamping. All limbs shall be removed from the sides of the live cutting prior to installation.

Live stakes shall be installed within 48 hours of cutting. Outside storage locations should be continually shaded and protected from wind and direct sunlight. Live cut plant material shall remain moist at all times before planting.

Stakes shall be spaced approximately 4 ft. on center. Live stakes shall be installed according to the configuration presented on the Streambank Reforestation Detail Sheets.

Tamp live stakes perpendicularly into the finished bank slope with a dead blow hammer, with buds oriented in an upward direction. Stakes should be tamped until approximately $\frac{3}{4}$ of the stake length is within the ground. The area around each live stake shall be compacted by foot after the live stake has been installed.

1"- 2" shall be cut cleanly off of the top of each live stake with loppers at an angle of approximately 15 degrees following installation. Any stakes that are split or damaged during installation shall be removed and replaced.

The bare root seedlings shall be planted as soon as practical following permanent *Seeding and Mulching*. The seedlings shall be planted from top of bank out, along both sides of the stream, as designated on the plans.

Root dip: The roots of reforestation seedlings shall be coated with a slurry of water, and either a fine clay (kaolin) or a superabsorbent that is designated as a bare root dip. The type, mixture ratio, method of application, and the time of application shall be submitted to the Engineer for approval.

With the approval of the Engineer, seedlings may be coated before delivery to the job or at the time of planting, but at no time shall the roots of the seedlings be allowed to dry out. The roots shall be moistened immediately prior to planting.

Seasonal Limitations: Streambank reforestation shall be planted from November 15 through March 15.

Measurement and Payment

Streambank Reforestation will be measured and paid for as the actual number of acres of land measured along the surface of the ground, which has been acceptably planted in accordance with this section.

Payment will be made under:

Pay Item	Pay Unit
Streambank Reforestation	Acre

SITE GRADING FOR MITIGATION:

Description

The Contractor shall perform grading as necessary to attain final surface elevations as shown on the plans and in the details.

Construction Methods

(A) Site Grading

The Contractor shall perform grading as necessary to attain final surface elevations as shown on the plans and in the details. Field modifications shall be approved by the Engineer. Final grades shall meet the plan and stream dimensions within a tolerance of +/- 0.2 feet (2.4 inches).

(B) Stream Excavation/Ditch Filling

In areas where ditches are to be filled, the Contractor shall comply with the requirements of Subarticle 235-3(C) of the *Standard Specifications* to obtain a minimum 95% compaction rate. Lift thickness shall not exceed 1 ft. and compaction shall be achieved by use of mechanical compaction equipment only. Fill material shall be such that the Plasticity Index (PI) shall be equal to or greater than that of the PI in each surrounding soil strata. Organic material shall not exceed 10% of the total volume of the fill material used. No compaction shall be performed for graded areas unless directed.

Excess material shall be disposed of as shown on the plans or as directed. **Estimated earthwork quantities: Excavation= 4,005 CY, Fill = 2,520 CY, Waste= 1,485 CY.**

Measurement and Payment

All work completed under this section will be paid for as lump sum for *Site Grading for Mitigation*.

The above prices and payments will be full compensation for all work covered by this section.

Payment will be made under:

Pay Item	Pay Unit
Site Grading for Mitigation	Lump Sum

SURVEYING FOR MITIGATION:**Description**

Surveying for Mitigation shall be performed in accordance with the applicable requirements of Section 801 of the *Standard Specifications* and shall include but not be limited to the layout of the stream channel, temporary and permanent easements, and all sensitive areas associated with the implementation of the design as indicated in the plans. The contractor shall maintain a level and rod onsite at all times for use by the Engineer to ensure adequate stream grades are achieved. This will not alleviate the contractor's responsibility to make certain that the stream is constructed in accordance with the project plans and provisions.

Construction Methods

Stakeout of the stream channel in its entirety shall be performed in such a way that the Engineer can verify the layout of the stream channel prior to construction activities commencing. The Contractor shall mark the proposed location of the top of banks and centerline of the channel. At a minimum, ditch stakes shall be placed to indicate the head of riffle and max pool locations within the proposed channel. Differing front and back slopes shall be indicated on the stake. Stakes should be maintained until final inspection of the project. There will be no additional payment for re-staking.

Upon completion of the stakeout and prior to beginning construction, the contractor shall give the Engineer a 48-hour notice in order to approve the stream alignment.

Measurement and Payment

Payment for surveying for mitigation will be made for providing all construction layout, boundary surveying, and engineering necessary for the proper construction of the project in accordance with the project plans and special provisions. Surveying for adjustments to the stream alignment shall be considered incidental to the lump sum price for *Surveying for Mitigation*.

Payment will be made under:

Pay Item	Pay Unit
Surveying for Mitigation	Lump Sum

PUMP AROUND OPERATION:**Description**

The work covered by this section consists of furnishing, installing, maintaining and removing any and all pump around systems used on this project. The Contractor shall install a pump around system in locations chosen by the contractor and approved by the Engineer. The pump around system shall provide a passageway for the stream flow around the work site.

The quantity of pump around systems may be increased, decreased, or eliminated entirely as directed. Such variations in quantity will not be considered as alterations in the details of construction or a change in the character of the work. See example pump around operation detail on the plans.

Construction Methods

Install a temporary impervious dike as shown on the detail. Pump water around the work site. If the water is turbid or exposed to bare soil, pump through a special stilling basin. Follow detail for the pump around operation. Once the work is complete in an area remove the impervious dike and pump system. Place structures in the area and stabilize immediately following removal of pump around system.

Measurement and Payment

Special Stilling Basins will be measured and paid for in accordance with Article 1639-4 of the Standard Specifications.

Impervious Dikes will be paid for as provided elsewhere in this contract.

Temporary flexible hose will be considered incidental to the pump around operation.

The pump around operation will be measured and paid for as lump sum for *Diversion Pumping*. This measurement shall include multiple installations and removals of the pump around system.

The above prices and payments will be full compensation for all work covered by this section including, but not limited to furnishing all of the necessary materials, construction, maintenance and removal of the pump around system.

Payment will be made under:

Pay Item	Pay Unit
Diversion Pumping	Lump Sum

IMPERVIOUS SELECT MATERIAL:

Description

This work consists of furnishing, stockpiling, placing and maintaining impervious select material for stream plugs in locations as shown on the plans and cross-sections or as directed.

The quantity of impervious select material to be installed will be affected by the actual conditions that occur during the construction of the project. The quantity of impervious select material may be increased, decreased, or eliminated entirely as directed. Such variations in quantity will not be considered as alterations in the details of construction or a change in the character of the work.

Materials

Materials that will function as impervious barriers to water movement shall be a silty or clay soil material meeting the requirements of AASHTP M 145 for soil classification A-2, A-6 and A-7 provided such materials do not have a Liquid Limit (LL) greater than 50. To maintain soil workability for placement and compaction, the following criteria shall apply for Plasticity Index (PI):

<u>Position of Borrow Material</u>	<u>Constraints on Plasticity Index (PI)</u>
Below the water table	Must be greater than 7 and less than 25
Above the water table	Must be greater than 7 and less than 35

Plasticity Index shall be determined in accordance with AASHTO T90 and the Liquid Limit shall be determined in accordance with AASHTO T89. The Contractor is cautioned that soils tend to become less workable as the PI increases above 20. Although a PI of 35 may be acceptable, the Contractor should be aware that additional efforts might be necessary to work the soil in order to achieve the minimum compaction standards.

Construction Methods

Impervious select material for stream plugs shall be constructed at locations as shown on the plans and cross-sections or as directed. Impervious select material for stream plugs shall be used at the outlet end of uncompacted channel fills, and may be used at other locations to provide surface drainage relief from the uncompacted fills.

(A) Clearing and Grubbing

Clear and Grub the stream plug cross-section on all sides to remove all vegetation and root mat material as directed to an elevation at least 1 ft. below the elevation of the existing channel cross-section.

(B) Construction

Construct the stream plug using material that meets the requirements of the Materials section listed above. Construct the stream plug to the dimensions detailed on the plans.

Measurement and Payment

Impervious Select Material will be measured and paid for as the actual number of cubic yards of material, measured in their original position and computed by the average end area method, which has been acceptably excavated in accordance with the plans and specifications. Original cross-sections for the determination of the excavation quantities will be taken before any grading begins. Final cross-sections will be taken after the excavation has been completed, except that the plan typical sections will be used for the final cross-sections where, in the opinion of the Engineer, the work has been constructed in reasonably close conformity to the plan typical

section. Original and final cross-sections will be taken by either ground or aerial survey methods, as determined by the Engineer.

Such price and payment will be full compensation for all work covered by this section, including but not limited to furnishing the source of the impervious select material; providing and implementing a development, use, and reclamation plan; building, maintaining, and obliterating haul roads; clearing and grubbing the source; removal and disposition of overburden and other unsuitable material; excavation; hauling; restoration of the source and haul roads to an acceptable condition; seeding and mulching; and maintaining the work.

Payment will be made under:

Pay Item	Pay Unit
Impervious Select Material	Cubic Yard

STREAM PLUG:

Description

This work consists of the construction, maintenance, and removal of physical barriers placed in ditches, diversions or swales to reduce water flow.

The quantity of stream plugs to be constructed will be affected by the actual conditions that occur during the construction of the project. The quantity of stream plugs may be increased, decreased, or eliminated entirely as directed. Such variations in quantity will not be considered as alterations in the details of construction or a change in the character of the work.

Materials

Stream plugs shall consist of *Impervious Select Material* that shall meet the specifications as provided elsewhere in this contract.

Construction Methods

Stream plugs shall be constructed at locations as shown on the plans or as directed. Clear and grub all side slopes of the channel. Place stream plug in channel ensuring that there is at least 5 ft. of embankment material between the plug and the face of the restored stream bank.

Measurement and Payment

Stream plugs will not be measured for payment under this article. *Impervious Select Material* will be measured and paid for as provided elsewhere in this contract. This payment shall be considered full compensation for all materials, labor, equipment, and incidentals necessary to construct the stream plug.

The removal and disposal of silt accumulations will be measured and paid for as *Silt Excavation* in accordance with Article 1630-4 of the *Standard Specifications*.

STRUCTURE STONE:

Description

This work consists of furnishing, stockpiling, placing and maintaining approved stone used to construct rock cross-vanes, rock vanes, j-hook vanes, w-rock cross vanes, log vanes, root wad/log vanes, log cross vanes, root wad structures, rock cross vanes for step pools, channel blocks, double wing deflectors, single wing deflectors, stream crossings, rock energy dissipaters, constructed riffles, and for use in other locations as directed.

The quantity of stone to be installed will be affected by the actual conditions that occur during the construction of the project. The quantity of stone may be increased, decreased, or eliminated entirely as directed. Such variations in quantity will not be considered as alterations in the details of construction or a change in the character of the work.

Materials

Refer to Division 10

Item	Section
No. 57 Stone	1005
Riprap, Class A, B, 1, and 2	1042
Geotextile for Drainage, Type 2	1056

Boulders shall meet the requirements of Section 1042 of the *Standard Specifications*. Boulders of minimum dimension 48" x 36" x 24" shall be individually picked for use in the structures. Boulders shall be relatively flat on either side in the same dimension, preferably the long dimension.

Construction Methods

The Contractor shall place geotextile and stone in locations and to the thickness, widths, and lengths as shown on the plans or as directed. All stone shall be placed to form a sediment and erosion control device, an in-stream structure, or a channel lining neatly and uniformly with an even surface in accordance with the contract and shall meet the approval of the Engineer.

Measurement and Payment

No. 57 Stone will be measured and paid as the actual number of tons that have been incorporated into the work, or have been delivered to and stockpiled on the project as directed. *No. 57 stone* that has been stockpiled will not be measured a second time.

Riprap, Class ___ will be measured and paid for in accordance with Article 876-4 of the *Standard Specifications*.

Geotextile for Drainage will be measured and paid for in accordance with Article 876-4 of the *Standard Specifications*.

Boulders will be measured and paid for as the actual number of tons that have been incorporated into the work, or have been delivered to and stockpiled on the project as directed. Stone that has been stockpiled will not be measured a second time.

Such price and payment will be full compensation for all work covered by this section, including but not limited to furnishing, weighing, stockpiling, re-handling, placing, and maintaining the stone and disposal of any materials not incorporated into the project.

Payment will be made under:

Pay Item	Pay Unit
No. 57 Stone	Ton
Boulder	Ton

ROCK CROSS VANE:

Description

This work consists of the construction and maintenance of physical barriers placed in and along the stream at locations designated on the plans to direct the stream flow (thalweg) toward the center of the channel and to provide grade control.

The quantity of rock cross vanes to be installed will be affected by the actual conditions that occur during the construction of the project. The quantity of rock cross vanes may be increased, decreased, or eliminated entirely as directed. Such variations in quantity will not be considered as alterations in the details of construction or a change in the character of the work.

Materials

Refer to Division 10

Item	Section
Boulder	1042 and SP for Structure Stone
No. 57 Stone	1005
Riprap, Class A	1042-1
Geotextile for Drainage, Type 2	1056

Boulders shall be used as header and footer rocks for this device.

Construction Methods

Rock cross vanes shall be constructed in accordance with the Rock Cross Vane Detail shown in the plans or as directed. Two vanes, each approximately 1/3 of the stream channel's bankfull width, will form a 20°– 30° angle out from the streambank toward upstream. The top elevation of both vanes will decrease from bankfull elevation toward the center of the channel at a slope of 4 to 20 percent. A vane running perpendicular to the stream's flow will connect the two outside vanes on the upstream end. Install header and footer rocks according to the detail and plate the upstream side with Type 2 geotextile and No. 57 stone. Voids between the header and footer rocks can be filled with hand-placed Class A riprap as directed. Footer rocks shall be placed such that the header rock is at streambed elevation. The rock cross vane shall be keyed into the bank at the downstream end as shown on the Rock Cross Vane Detail.

Measurement and Payment

Boulders will be measured and paid for as provided elsewhere in this contract.

No. 57 Stone will be measured and paid for as provided elsewhere in this contract.

Riprap, Class __ will be measured and paid for in accordance with Article 876-4 of the *Standard Specifications*.

Geotextile for Drainage will be measured and paid for in accordance with Article 876-4 of the *Standard Specifications*.

Such price and payment will be full compensation for all work covered by this section, including, but not limited to furnishing all materials, labor, equipment, and incidentals necessary to construct the rock cross vanes.

CONSTRUCTED RIFFLE:

Description

This work consists of the construction and maintenance of physical barriers placed in and along the stream at locations designated on the plans to provide grade control.

The quantity of constructed riffles to be installed will be affected by the actual conditions that occur during the construction of the project. The quantity of constructed riffles may be increased, decreased, or eliminated entirely as directed. Such variations in quantity will not be considered as alterations in the details of construction or a change in the character of the work.

Materials

Item	Section
Boulder	1042 and SP for Structure Stone
No. 57 Stone	Section 1005

Riprap, Class A and B
Geotextile for Drainage, Type 2

Section 1042-1
1056

Construction Methods

Constructed riffles shall be constructed according to the Constructed Riffle Detail shown on the plans or as directed.

Measurement and Payment

Boulders will be measured and paid for as provided elsewhere in this contract.

No. 57 Stone will be measured and paid for as provided elsewhere in this contract.

Riprap, Class __ will be measured and paid for in accordance with Article 876-4 of the *Standard Specifications*.

Geotextile for Drainage will be measured and paid for in accordance with Article 876-4 of the *Standard Specifications*.

Such price and payment will be full compensation for all work covered by this section, including, but not limited to, furnishing all materials, labor, equipment and incidentals necessary to construct the constructed riffles.

U-2707

Signals and Intelligent Transportation Systems
Project Special Provisions
(Version 12.4)

Prepared By: iou
5-Jan-16

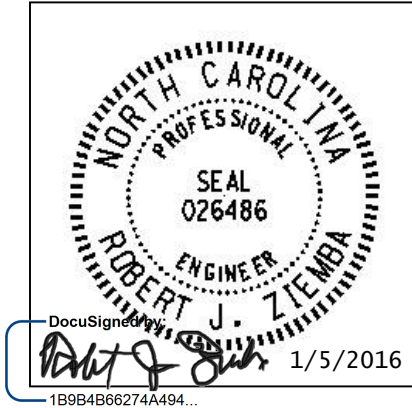

Contents

1. 2012 STANDARD SPECIFICATIONS FOR ROADS & STRUCTURES.....2

1.1. POLYMER CONCRETE (PC) JUNCTION BOXES (1091-5(B)).....2

1.2. SUBMITTAL REQUIREMENTS (1098-1(B))2

1.3. JUNCTION BOXES (1098-5).....2

1.4. CONTROLLERS WITH CABINETS – MATERIAL (1751-2)2

2. SIGNAL HEADS.....2

2.1. MATERIALS2

A. General:.....2

B. Vehicle Signal Heads:.....4

C. Signal Cable:.....6

3. TRAFFIC SIGNAL SUPPORTS.....6

3.1. METAL TRAFFIC SIGNAL SUPPORTS – ALL POLES6

A. General:.....6

B. Materials:9

C. Construction Methods:10

3.2. METAL POLE UPRIGHTS (VERTICAL MEMBERS)10

A. Materials:10

3.3. STRAIN POLE SHAFTS11

3.4. DRILLED PIER FOUNDATIONS FOR METAL TRAFFIC SIGNAL POLES12

A. Description:12

B. Soil Test and Foundation Determination:13

C. Drilled Pier Construction:15

3.5. CUSTOM DESIGN OF TRAFFIC SIGNAL SUPPORTS15

A. General:.....15

B. Metal Poles:.....16

3.6. POLE NUMBERING SYSTEM18

3.7. MEASUREMENT AND PAYMENT18

4. CONTROLLERS WITH CABINETS19

4.1. MATERIALS – TYPE 2070L CONTROLLERS19

4.2. MATERIALS – GENERAL CABINETS19

4.3. MATERIALS – TYPE 170E CABINETS20

A. Type 170 E Cabinets General:.....20

B. Type 170 E Cabinet Electrical Requirements:.....21

C. Type 170 E Cabinet Physical Requirements:.....27

D. Model 2018 Enhanced Conflict Monitor:28

4.4. MATERIALS – TYPE 2070E CONTROLLERS37

1. 2012 STANDARD SPECIFICATIONS FOR ROADS & STRUCTURES

The 2012 Standard Specifications are revised as follows:

1.1. Polymer Concrete (PC) Junction Boxes (1091-5(B))

Page 10-202, revise paragraph starting on line 9 to read “Provide polymer concrete (PC) boxes which have bolted covers and open bottoms. Provide vertical extensions of 6" to 12" as required by project special provisions.”

Page 10-202, revise sentence beginning on line 14 to read “Other thermoplastic materials may be used for components which are not normally exposed to sunlight.”

1.2. Submittal Requirements (1098-1(B))

Page 10-208, replace paragraph on line 34 with the following:

Submit for approval catalog cuts and/or shop drawings for materials proposed for use on the project. Allow 40 days for review of each submittal. Do not fabricate or order material until receipt of Engineer’s approval.

Submit 4 copies of each catalog cut and/or drawing and show for each component the material description, brand name, stock-number, size, rating, manufacturing specification and the intended use (identified by labeling all components with the corresponding contract line item number). Present the submittals neatly arranged in the same order as the contract bid items. Electronic submittals of catalog cuts and drawings may be accepted in lieu of hard copies.

One hard copy and an electronic (PDF) copy of reviewed submittals will be returned to the Engineer from the ITS and Signals Unit.

1.3. Junction Boxes (1098-5)

Page 10-212, sub-Section 1098-5(C) Oversized Junction Boxes

Revise sentence to read, “Provide oversized junction boxes and covers with minimum inside dimensions of 28"(l) x 15"(w) x 22"(h).”

1.4. Controllers with Cabinets – Material (1751-2)

Page 17-37, Section 1751-2 Material

Add the following paragraph:

When the plans or specifications require a Type 2070L controller, contractor may provide a Type 2070E controller. Unless otherwise allowed by the Engineer, provide controllers of only one type.

2. SIGNAL HEADS

2.1. MATERIALS

A. General:

Fabricate vehicle signal head housings and end caps from die-cast aluminum. Provide visor mounting screws, door latches, and hinge pins fabricated from stainless steel. Provide interior screws, fasteners, and metal parts fabricated from stainless steel or corrosion resistant material.

Fabricate tunnel and traditional visors from sheet aluminum.

Paint all surfaces inside and outside of signal housings and doors. Paint outside surfaces of tunnel and traditional visors, messenger cable mounting assemblies, pole and pedestal mounting

assemblies, and pedestrian pushbutton housings. Have electrostatically-applied, fused-polyester paint in highway yellow (Federal Standard 595C, Color Chip Number 13538) a minimum of 2.5 to 3.5 mils thick. Do not apply paint to the latching hardware or rigid vehicle signal head mounting brackets for mast-arm attachments.

Have the interior surfaces of tunnel and traditional visors painted an alkyd urea black synthetic baking enamel with a minimum gloss reflectance and meeting the requirements of MIL-E-10169, "Enamel Heat Resisting, Instrument Black."

Where required, provide polycarbonate signal heads and visors that comply with the provisions pertaining to the aluminum signal heads listed on the QPL with the following exceptions:

Fabricate signal head housings, end caps, and visors from virgin polycarbonate material. Provide UV stabilized polycarbonate plastic with a minimum thickness of 0.1 ± 0.01 inches that is highway yellow (Federal Standard 595C, Color Chip 13538). Ensure the color is incorporated into the plastic material before molding the signal head housings and end caps. Ensure the plastic formulation provides the following physical properties in the assembly (tests may be performed on separately molded specimens):

Test	Required	Method
Specific Gravity	1.17 minimum	ASTM D 792
Flammability	Self-extinguishing	ASTM D 635
Tensile Strength, yield, PSI	8500 minimum	ASTM D 638
Izod impact strength, ft-lb/in [notched, 1/8 inch]	12 minimum	ASTM D 256

For pole mounting, provide side of pole mounting assemblies with framework and all other hardware necessary to make complete, watertight connections of the signal heads to the poles and pedestals. Fabricate the mounting assemblies and frames from aluminum with all necessary hardware, screws, washers, etc. to be stainless steel. Provide mounting fittings that match the positive locking device on the signal head with the serrations integrally cast into the brackets. Provide upper and lower pole plates that have a 1 ¼-inch vertical conduit entrance hubs with the hubs capped on the lower plate and 1 ½-inch horizontal hubs. Ensure that the assemblies provide rigid attachments to poles and pedestals so as to allow no twisting or swaying of the signal heads. Ensure that all raceways are free of sharp edges and protrusions, and can accommodate a minimum of ten Number 14 AWG conductors.

For light emitting diode (LED) traffic signal modules, provide the following requirements for inclusion on the Department's Qualified Products List for traffic signal equipment.

1. Sample submittal,
2. Third-party independent laboratory testing results for each submitted module with evidence of testing and conformance with all of the Design Qualification Testing specified in section 6.4 of each of the following Institute of Transportation Engineers (ITE) specifications:
 - Vehicle Traffic Control Signal Heads – Light Emitting Diode (LED) Circular Signal Supplement
 - Vehicle Traffic Control Signal Heads – Light Emitting Diode (LED) Vehicle Arrow Traffic Signal Supplement
 - Pedestrian Traffic Control Signal Indications –Light Emitting Diode (LED) Signal Modules.

(Note: The Department currently recognizes two approved independent testing laboratories. They are Intertek ETL Semko and Light Metrics, Incorporated with Garwood Laboratories. Independent laboratory tests from other laboratories may be considered as part of the QPL submittal at the discretion of the Department,

3. Evidence of conformance with the requirements of these specifications,
4. A manufacturer's warranty statement in accordance with the required warranty, and
5. Submittal of manufacturer's design and production documentation for the model, including but not limited to, electrical schematics, electronic component values, proprietary part numbers, bill of materials, and production electrical and photometric test parameters.
6. Evidence of approval of the product to bear the Intertek ETL Verified product label for LED traffic signal modules.

In addition to meeting the performance requirements for the minimum period of 60 months, provide a written warranty against defects in materials and workmanship for the modules for a period of 60 months after installation of the modules. During the warranty period, the manufacturer must provide new replacement modules within 45 days of receipt of modules that have failed at no cost to the State. Repaired or refurbished modules may not be used to fulfill the manufacturer's warranty obligations. Provide manufacturer's warranty documentation to the Department during evaluation of product for inclusion on Qualified Products List (QPL).

B. Vehicle Signal Heads:

Comply with the ITE standard "Vehicle Traffic Control Signal Heads". Provide housings with provisions for attaching backplates.

Provide visors that are 10 inches in length for 12-inch vehicle signal heads.

Provide a termination block with one empty terminal for field wiring for each indication plus one empty terminal for the neutral conductor. Have all signal sections wired to the termination block. Provide barriers between the terminals that have terminal screws with a minimum Number 8 thread size and that will accommodate and secure spade lugs sized for a Number 10 terminal screw.

Mount termination blocks in the yellow signal head sections on all in-line vehicle signal heads. Mount the termination block in the red section on five-section vehicle signal heads.

Furnish vehicle signal head interconnecting brackets. Provide one-piece aluminum brackets less than 4.5 inches in height and with no threaded pipe connections. Provide hand holes on the bottom of the brackets to aid in installing wires to the signal heads. Lower brackets that carry no wires and are used only for connecting the bottom signal sections together may be flat in construction.

For messenger cable mounting, provide messenger cable hangers, wire outlet bodies, balance adjusters, bottom caps, wire entrance fitting brackets, and all other hardware necessary to make complete, watertight connections of the vehicle signal heads to the messenger cable. Fabricate mounting assemblies from malleable iron or steel and provide serrated rings made of aluminum. Provide messenger cable hangers and balance adjusters that are galvanized before being painted. Fabricate balance adjuster eyebolt and eyebolt nut from stainless steel or galvanized malleable iron. Provide messenger cable hangers with U-bolt clamps. Fabricate washers, screws, bolts, clevis pins, cotter pins, nuts, and U-bolt clamps from stainless steel.

Provide LED vehicular traffic signal modules (hereafter referred to as modules) that consist of an assembly that uses LEDs as the light source in lieu of an incandescent lamp for use in traffic signal sections. Use LEDs that are aluminum indium gallium phosphorus (AlInGaP) technology for red and yellow indications and indium gallium nitride (InGaN) for green indications. Install the ultra bright type LEDs that are rated for 100,000 hours of continuous operation from -40°F to +165°F. Design modules to have a minimum useful life of 60 months and to meet all parameters of this specification during this period of useful life.

For the modules, provide spade terminals crimped to the lead wires and sized for a #10 screw connection to the existing terminal block in a standard signal head. Do not provide other types of crimped terminals with a spade adapter.

Ensure the power supply is integral to the module assembly. On the back of the module, permanently mark the date of manufacture (month & year) or some other method of identifying date of manufacture.

Tint the red, yellow and green lenses to correspond with the wavelength (chromaticity) of the LED. Transparent tinting films are unacceptable. Provide a lens that is integral to the unit with a smooth outer surface.

1. LED Circular Signal Modules:

Provide modules in the following configurations: 12-inch circular sections. All makes and models of LED modules purchased for use on the State Highway System shall appear on the current NCDOT Traffic Signal Qualified Products List (QPL).

Provide the manufacturer's model number and the product number (assigned by the Department) for each module that appears on the 2012 or most recent Qualified Products List. In addition, provide manufacturer's certification in accordance with Article 106-3 of the *Standard Specifications*, that each module meets or exceeds the ITE "Vehicle Traffic Control Signal Heads – Light Emitting Diode (LED) Circular Signal Supplement" dated June 27, 2005 (hereafter referred to as VTCSH Circular Supplement) and other requirements stated in this specification.

Provide modules that meet the following requirements when tested under the procedures outlined in the VTCSH Circular Supplement:

Module Type	Max. Wattage at 165° F	Nominal Wattage at 77° F
12-inch red circular	17	11
12-inch green circular	15	15

For yellow circular signal modules, provide modules tested under the procedures outlined in the VTCSH Circular Supplement to insure power required at 77° F is 22 Watts or less for the 12-inch circular module.

Note: Use a wattmeter having an accuracy of $\pm 1\%$ to measure the nominal wattage and maximum wattage of a circular traffic signal module. Power may also be derived from voltage, current and power factor measurements.

2. LED Arrow Signal Modules

Provide 12-inch omnidirectional arrow signal modules. All makes and models of LED modules purchased for use on the State Highway System shall appear on the current NCDOT Traffic Signal Qualified Products List (QPL).

Provide the manufacturer's model number and the product number (assigned by the Department) for each module that appears on the 2012 or most recent Qualified Products List. In addition, provide manufacturer's certification in accordance with Article 106-3 of the *Standard Specifications*, that each module meets or exceeds the requirements for 12-inch omnidirectional modules specified in the ITE "Vehicle Traffic Control Signal Heads – Light Emitting Diode (LED) Vehicle Arrow Traffic Signal Supplement" dated July 1, 2007 (hereafter referred to as VTCSH Arrow Supplement) and other requirements stated in this specification.

Provide modules that meet the following requirements when tested under the procedures outlined in the VTCSH Arrow Supplement:

Module Type	Max. Wattage at 165° F	Nominal Wattage at 77° F
12-inch red arrow	12	9
12-inch green arrow	11	11

For yellow arrow signal modules, provide modules tested under the procedures outlined in the VTCSH Arrow Supplement to insure power required at 77° F is 12 Watts or less.

Note: Use a wattmeter having an accuracy of $\pm 1\%$ to measure the nominal wattage and maximum wattage of an arrow traffic signal module. Power may also be derived from voltage, current and power factor measurements.

C. Signal Cable:

Furnish 16-4 and 16-7 signal cable that complies with IMSA specification 20-1 except provide the following conductor insulation colors:

- For 16-4 cable: white, yellow, red, and green
- For 16-7 cable: white, yellow, red, green, yellow with black stripe tracer, red with black stripe tracer, and green with black stripe tracer. Apply continuous stripe tracer on conductor insulation with a longitudinal or spiral pattern.

Provide a ripcord to allow the cable jacket to be opened without using a cutter. IMSA specification 19-1 will not be acceptable. Provide a cable jacket labeled with the IMSA specification number and provide conductors constructed of stranded copper.

3. TRAFFIC SIGNAL SUPPORTS

3.1. METAL TRAFFIC SIGNAL SUPPORTS – ALL POLES

A. General:

Furnish and install metal strain poles, grounding systems, and all necessary hardware. The work covered by this special provision includes requirements for the design, fabrication, and installation of both standard and custom/site specifically designed metal traffic signal supports and associated foundations.

Provide metal traffic signal support systems that contain no guy assemblies, struts, or stay braces. Provide designs of completed assemblies with hardware that equals or exceeds AASHTO *Standard Specifications for Structural Supports for Highway Signs, Luminaires and Traffic Signals* 5th Edition, 2009 (hereafter called 5th Edition AASHTO), including the latest interim specifications. Provide assemblies with a round or near-round (18 sides or more) cross-section, or a multi sided cross section with no less than six sides. The sides may be straight, convex, or concave.

Pole heights shown on signal plans are estimated from available data for bid purposes. Prior to furnishing metal signal poles, use field measurements and adjusted cross-sections to determine whether pole heights are sufficient to obtain required clearances. If pole heights are not sufficient, the Contractor should immediately notify the Engineer of the required revised pole heights.

Ensure that metal signal poles permit cables to be installed inside poles and any required mast arms. For holes in the poles and arms used to accommodate cables, provide full-circumference grommets. Arm flange plate wire access holes should be deburred, non grommets, and oversized to fit around the 2" diameter grommets shaft flange plate wire access hole.

After fabrication, have steel poles, required mast arms, and all parts used in the assembly hot-dip galvanized per section 1076. Design structural assemblies with weep holes large enough and properly located to drain molten zinc during the galvanization process. Provide hot-dip galvanizing on structures that meets or exceeds ASTM Standard A-123. Provide galvanizing on hardware that meets or exceeds ASTM Standard A-153. Ensure that threaded material is brushed and retapped as necessary after galvanizing. Perform repair of damaged galvanizing that complies with the following:

Repair of GalvanizingArticle 1076-7

Standard Drawings for Metal Poles are available that supplement these project special provisions. These drawings are located on the Department's website:

<https://connect.ncdot.gov/resources/safety/pages/ITS-Design-Resources.aspx>

Comply with article 1098-1B of the *2012 STANDARD SPECIFICATIONS FOR ROADS & STRUCTURES*, hereinafter referred to as the *Standard Specifications* for submittal requirements. Furnish shop drawings for approval. Provide the copies of detailed shop drawings for each type of structure as summarized below. Ensure that shop drawings include material specifications for each component and identify welds by type and size on the detail drawing only, not in table format. **Do not release structures for fabrication until shop drawings have been approved by NCDOT.** Provide an itemized bill of materials for all structural components and associated connecting hardware on the drawings.

Comply with article 1098-1A of the *Standard Specifications* for Qualified Products List (QPL) submittals. All shop drawings must include project location description, signal inventory number(s) and a project number or work order number on the drawings.

Summary of information required for metal pole review submittal:

Item	Hardcopy Submittal	Electronic Submittal	Comments / Special Instructions
Sealed, Approved Signal Plan/Loading Diagram	1	1	All structure design information needs to reflect the latest approved signal plans
Custom Pole Shop Drawings	4 sets	1 set	Show NCDOT inventory number(s), contractor's name and relevant revision number in the title block. All drawings must have a unique <u>drawing</u> number for each project and identified for multiple pages.
Standard Pole Shop Drawings (from the QPL)	4 sets	1 set	Submit drawings on 11" x 17" format media. Show NCDOT inventory number(s), contractor's name and relevant revision number in the title block. All drawings must have a <u>unique drawing</u> number for each project and identified for multiple pages.
Structure Calculations	1 set	1 set	Not required for Standard QPL Poles
Standard Pole Foundation Drawings	1 set	1 set	Submit drawings on 11" x 17" format media. Submit a completed Standard Foundation Selection form for each pole using foundation table on Metal Pole Drawing M-8.
Custom Foundation Drawings	4 sets	1 set	Submit drawings on 11" x 17" format media. Show NCDOT inventory number(s), contractor's name and relevant revision number in the title block. All drawings must have a <u>unique drawing</u> number for each project and identified for multiple pages. If QPL Poles are used, include the corresponding QPL pole shop drawings with this submittal.
Foundation Calculations	1	1	Submit copies of LPILE input, output and pile tip deflection graph per Section 11.4 of this specification for each foundation. Not required for Standard QPL Poles
Soil Boring Logs and Report	1	1	Report should include a location plan and a soil classification report including soil capacity, water level, hammer efficiency, soil bearing pressure, soil density, etc. for each pole.

NOTE – All shop drawings and custom foundation design drawings must be sealed by a Professional Engineer licensed in the state of North Carolina. All geotechnical information must be sealed by either a Professional Engineer or geologist licensed in the state of North Carolina. Include a title block and revision block on the shop drawings and foundation drawings showing the NCDOT inventory number.

Shop drawings and foundation drawings may be submitted together or separately for approval. However, shop drawings must be approved before foundations can be reviewed.

Foundation designs will be returned without review if the associated shop drawing has not been approved. Incomplete submittals will be returned without review. The Reviewer has the right to request additional analysis and copies of the calculations to expedite the approval process.

B. Materials:

Fabricate metal pole and arm shaft from coil or plate steel to meet the requirements of ASTM A 595 Grade A tubes. For structural steel shapes, plates and bars use A572 Gr 50 min or ASTM A709 Gr 50 min. Provide pole and arm shafts that are round in cross section or multisided tubular shapes and have a uniform linear taper of 0.14 in/ft. Construct shafts from one piece of single ply plate or coil so there are no circumferential weld splices. Galvanize in accordance with AASHTO M 111 or an approved equivalent.

Use the submerged arc process or other NCDOT previously approved process suitable for pole shaft and arms to continuously weld pole shafts and arm shafts along their entire length. The longitudinal seam weld will be finished flush to the outside contour of the base metal. Ensure shafts have no circumferential welds except at the lower end joining the shaft to the pole base and arm base. Provide welding that conforms to Article 1072-18 of the *Standard Specifications*, except that no field welding on any part of the pole will be permitted unless approved by a qualified engineer.

Refer to Metal Pole Standard Drawing Sheets M2 through M5 for fabrication details. Fabricate anchor bases from plate steel meeting, as a minimum, the requirements of ASTM A 36M or cast steel meeting the requirements of ASTM A 27M Grade 485-250, AASHTO M270 Gr 36 or an approved equivalent. Conform to the applicable bolt pattern and orientation as shown on Metal Pole Standard Drawing Sheet M2.

Ensure all hardware is galvanized steel or stainless steel. The Contractor is responsible for ensuring that the designer/fabricator specifies connecting hardware and/or materials that do not create a dissimilar metal corrosive reaction.

Provide a minimum of four (4) 1-1/2" diameter high strength bolts for connection between arm plate and pole plate. Increase number of bolts to six (6) 1-1/2" diameter high strength bolts when arm lengths are greater than 50'-0" long.

Unless otherwise required by the design, ensure each anchor rod is 2" diameter and 60" length. Provide 10" minimum thread projection at the top of the rod, and 8" minimum at the bottom of the rod. Use anchor rod assembly and drilled pier foundation materials that meet the *Foundations and Anchor Rod Assemblies for Metal Poles* provision.

For each structural bolt and other steel hardware, hot dip galvanizing shall conform to the requirements of AASHTO M 232 (ASTM A 153). Ensure end caps for poles or mast arms are constructed of cast aluminum conforming to Aluminum Alloy 356.0F.

Provide a circular anchor bolt lock plate that will be secured to the anchor bolts at the embedded end with 2 washers and 2 nuts. Provide a base plate template that matches the bolt circle diameter of the anchor bolt lock plate. Construct plates and templates from 1/4" minimum thick steel with a minimum width of 4". Galvanizing is not required for both plates.

Provide 4 heavy hex nuts and 4 flat washers for each anchor bolt. For nuts, use AASHTO M291 grade 2H, DH, or DH3 or equivalent material. For flat washers, use AASHTO M293 or equivalent material.

C. Construction Methods:

Erect signal support poles only after concrete has attained a minimum allowable compressive strength of 3000 psi. Install anchor rod assemblies in accordance with the *Foundations and Anchor Rod Assemblies for Metal Poles* provision.

For further construction methods, see construction methods for Metal Strain Pole.

Connect poles to grounding electrodes and bond them to the electrical service grounding electrodes.

For holes in the poles used to accommodate cables, install grommets before wiring pole or arm. Do not cut or split grommets.

Attach the terminal compartment cover to the pole by a sturdy chain or cable. Ensure the chain or cable is long enough to permit the cover to hang clear of the compartment opening when the cover is removed, and is strong enough to prevent vandalism. Ensure the chain or cable will not interfere with service to the cables in the pole base.

Attach cap to pole with a sturdy chain or cable. Ensure the chain or cable is long enough to permit the cap to hang clear of the opening when the cap is removed.

Perform repair of damaged galvanizing that complies with the *Standard Specifications*, Article 1076-7 "Repair of Galvanizing."

Install galvanized wire mesh around the perimeter of the base plate to cover the gap between the base plate and top of foundation for debris and pest control.

Install a ¼" thick plate for concrete foundation tag to include: concrete grade, depth, diameter, and reinforcement sizes of the installed foundation.

3.2. METAL POLE UPRIGHTS (VERTICAL MEMBERS)

A. Materials:

- Provide tapered tubular shafts and fabricated of steel conforming to ASTM A-595 Grade A or an approved equivalent.
- Hot-dip galvanize poles in accordance with AASHTO M 111 or an approved equivalent.
- Have shafts that are continuously welded for the entire length by the submerged arc process, and with exposed welds ground or rolled smooth and flush with the base metal. Provide welding that conforms to Article 1072-18 of the *Standard Specification* except that no field welding on any part of the pole will be permitted.
- Have Shafts with no circumferential welds except at the lower end joining the shaft to the base.
- Have anchor bases for steel poles fabricated from plate steel meeting as a minimum the requirements of ASTM A 36M or cast steel meeting the requirements of ASTM A 27M Grade 485-250 or an approved equivalent.

Provide a grounding lug(s) in the approximate vicinity of the messenger cable clamp for bonding and grounding messenger cable. Lugs must accept #4 or #6 AWG wire to bond messenger cables to the pole in order to provide an effective ground fault circuit path. Refer to Metal Pole Standard Drawing Sheet M6 for construction details.

Have poles permanently stamped above the hand holes with the identification tag details as shown on Metal Pole Standard Drawing Sheet M2.

Provide liquid tight flexible metal conduit (Type LFMC), liquid tight flexible nonmetallic conduit (Type LFNC), high density polyethylene conduit (Type HDPE), or approved equivalent to isolate conductors feeding luminaires.

Fabricate poles from a single piece of steel or aluminum with single line seam weld with no transverse butt welds. Fabrication of two ply pole shafts is unacceptable with the exception of fluted shafts. Provide tapers for all shafts that begin at base and that have diameters which decrease uniformly at the rate of not more than 0.14 inch per foot (11.7 millimeters per meter) of length.

Provide four anchor nuts and four washers for each anchor bolt. Ensure that anchor bolts have required diameters, lengths, and positions, and will develop strengths comparable to their respective poles.

Provide a terminal compartment with cover and screws in each pole that encompasses the hand hole and contains a 12-terminal barrier type terminal block. Provide two terminal screws with a removable shorting bar between them for each termination. Furnish terminal compartment covers attached to the pole by a sturdy chain or cable approved by the Engineer. Ensure that the chain or cable is long enough to permit the cover to hang clear of the compartment opening when the cover is removed, and is strong enough to prevent vandals from being able to disconnect the cover from the pole. Ensure that the chain or cable will not interfere with service to the cables in the pole base.

Install grounding lugs that will accept #4 or #6 AWG wire to electrically bond messenger cables to the pole. Refer to Metal Pole Standard Drawing Sheet M6 for construction details.

For each pole, provide a 1/2 inch minimum thread diameter, coarse thread stud and nut for grounding which will accommodate #6 AWG ground wire. Ensure that the lug is electrically bonded to the pole and is conveniently located inside the pole at the hand hole.

Provide a removable pole cap with stainless steel attachment screws for the top of each pole. Ensure that the cap is cast aluminum conforming to Aluminum Association Alloy 356.0F. Furnish cap attached to the pole with a sturdy chain or cable approved by the Engineer. Ensure that the chain or cable is long enough to permit the cap to hang clear of the pole-top opening when the cap is removed.

When required by the plans, furnish couplings 42 inches above the bottom of the base for mounting of pedestrian pushbuttons. Provide mounting points consisting of 1-1/2 inch internally threaded half-couplings that comply with the NEC and that are mounted within the poles. Ensure that couplings are essentially flush with the outside surfaces of the poles and are installed before any required galvanizing. Provide a threaded plug in each mounting point. Ensure that the surface of the plug is essentially flush with the outer end of the mounting point when installed and has a recessed hole to accommodate a standard wrench.

3.3. STRAIN POLE SHAFTS

Provide 2 messenger cable (span wire) clamps and associated hardware for attachment of messenger cable. Ensure that diameter of the clamp is appropriate to its location on the pole and is appropriately designed to be adjustable from 1'-6" below the top, down to 6'-6" below the top of the pole. Do not attach more than one support cable to a messenger cable clamp.

Provide a minimum of three (3) 2 inch (50 mm) holes equipped with an associated coupling and weatherhead on the messenger cable load side of the pole to accommodate passage of signal cables from inside the pole. Provide galvanized threaded plugs for all unused couplings at pole entrance points. Refer to Metal Pole Standard Drawing Sheet M3 for fabrication details.

Ensure that allowable pole deflection does not exceed that allowed per 5th Edition AASHTO. Ensure maximum deflection at the top of the pole does not exceed 2.5 percent of the pole height.

3.4. DRILLED PIER FOUNDATIONS FOR METAL TRAFFIC SIGNAL POLES

Analysis procedures and formulas shall be based on AASHTO 5th Edition, latest ACI code and the *Drilled Shafts: Construction Procedures and Design Methods* FHWA-IF99-025 manual. Design methods based on engineering publications or research papers needs to have prior approval from NCDOT. The Department reserves the right to accept or disapprove any method used for the analysis.

Use a Factor of Safety of 1.33 for torsion and 2.0 for bending for the foundation design.

Foundation design for lateral load shall not exceed 1" lateral deflection at top of foundation.

For lateral analysis, use LPILE Plus V6.0 or later. Inputs, results and corresponding graphs are to be submitted with the design calculations.

Skin Friction is to be calculated using the α -method for cohesive soils and the β -method for cohesion-less soils (**Broms method will not be accepted**). Detailed descriptions of the " α " and " β " methods can be found in *FHWA-IF-99-025*.

Omit first 2.5ft for cohesive soils when calculating skin friction.

When extreme loading and poor soil conditions are encountered, the one diameter length omitted from the shaft depth calculations (per FHWA-IF-99-025) may be added back in for Torsion calculations (with prior NCDOT approval).

When hammer efficiency is not provided, assume a value of 0.70.

Design all custom foundations to carry the maximum capacity of each metal pole. For standard case strain poles only, if a custom foundation is designed, use the actual shear, axial and moment reactions from the Standard Foundation Selection Table shown on Standard Drawing No. M8.

When poor soil conditions are encountered which could create an excessively large foundation design, consideration may be given to allowing an exemption to the maximum capacity design. The contractor must gain approval from the engineer before reducing a foundation's capacity. On projects where poor soil is known to be present, it is advisable that the contractor consider getting foundations approved before releasing poles for fabrication.

Have the contractor notify the engineer if the proposed foundation is to be installed on a slope other than 8H: 1V or flatter.

A. Description:

Furnish and install foundations for NCDOT metal poles with all necessary hardware in accordance with the plans and specifications.

Metal Pole Standards have been developed and implemented by NCDOT for use at signalized intersections in North Carolina. If the plans call for a standard pole, then a standard foundation may be selected from the plans. However, the Contractor is not required to use a standard foundation. If

the Contractor chooses to design a non-standard site-specific foundation for a standard pole or if the plans call for a non-standard site-specific pole, design the foundation to conform to the applicable provisions in the NCDOT Metal Pole Standard Drawings and Section B7 (Non-Standard Foundation Design) below. If non-standard site specific foundations are designed for standard QPL approved strain poles, the foundation designer must use the design moment specified by load case on Metal Pole Standard Drawing Sheet M8. Failure to conform to this requirement will be grounds for rejection of the design.

If the Contractor chooses to design a non-standard foundation for a standard pole and the soil test results indicate a standard foundation is feasible for the site, the Contractor will be paid the cost of the standard foundation (drilled pier and wing wall, if applicable). Any additional costs associated with a non-standard site-specific foundation including additional materials, labor and equipment will be considered incidental to the cost of the standard foundation. All costs for the non-standard foundation design will also be considered incidental to the cost of the standard foundation.

B. Soil Test and Foundation Determination:

1. General:

Drilled piers are reinforced concrete sections, cast-in-place against in situ, undisturbed material. Drilled piers are of straight shaft type and vertical.

Some standard drilled piers for supporting poles with mast arms may require wing walls to resist torsional rotation. Based upon this provision and the results of the required soil test, a drilled pier length and wing wall requirement may be determined and constructed in accordance with the plans.

For non-standard site-specific poles, the contractor-selected pole fabricator will determine if the addition of wing walls is necessary for the supporting foundations.

2. Soil Test:

Perform a soil test at each proposed metal pole location. Complete all required fill placement and excavation at each signal pole location to finished grade before drilling each boring. Soil tests performed that are not in compliance with this requirement may be rejected and will not be paid. Drill one boring to a depth of 26 feet within a 25 foot radius of each proposed foundation.

Perform standard penetration tests (SPT) in accordance with ASTM D 1586 at depths of 1, 2.5, 5, 7.5, 10, 15, 20 and 26 feet. Discontinue the boring if one of the following occurs:

- A total of 100 blows have been applied in any 2 consecutive 6-in. intervals.
- A total of 50 blows have been applied with < 3-in. penetration.

Describe each intersection as the “Intersection of (Route or SR #), (Street Name) and (Route or SR #), (Street Name), _____ County, Signal Inventory No. _____”. Label borings with “B- N, S, E, W, NE, NW, SE or SW” corresponding to the quadrant location within the intersection. Pole numbers should be made available to the Drill Contractor. Include pole numbers in the boring label if they are available. If they are not available, ensure the boring labels can be cross-referenced to corresponding pole numbers. For each boring, submit a legible (hand written or typed) boring log signed and sealed by a licensed Geologist or Professional Engineer registered in North Carolina. Include on each boring the SPT blow counts and N-values at each depth, depth of the boring, hammer efficiency, depth of water table and a general description of the soil types encountered using the AASHTO Classification System.

3. Standard Foundation Determination:

Use the following method for determining the Design N-value:

$$N_{AVG} = \frac{(N@1' + N@2.5' + \dots + N@Deepest \text{ Boring Depth})}{\text{Total Number of N-values}}$$

$$Y = (N@1')^2 + (N@2.5')^2 + \dots + (N@Deepest \text{ Boring Depth})^2$$

$$Z = (N@1' + N@2.5' + \dots + N@Deepest \text{ Boring Depth})$$

$$N_{STD \text{ DEV}} = \left[\frac{(\text{Total Number of N-values} \times Y) - Z^2}{(\text{Total Number of N-values}) \times (\text{Total Number of N-values} - 1)} \right]^{0.5}$$

Design N-value equals lesser of the following two conditions:

$$N_{AVG} - (N_{STD \text{ DEV}} \times 0.45)$$

Or

$$\text{Average of First Four N-Values} = \frac{(N@1' + N@2.5' + N@5' + N@7.5')}{4}$$

Note: If less than 4 N-values are obtained because of criteria listed in Section 2 above, use average of N-values collected for second condition. Do not include the N-value at the deepest boring depth for above calculations if the boring is discontinued at or before the required boring depth because of criteria listed in Section 2 above. Use N-value of zero for weight of hammer or weight of rod. If N-value is greater than 50, reduce N-value to 50 for calculations.

If standard NCDOT strain poles are shown on the plans and the Contractor chooses to use standard foundations, determine a drilled pier length, "L," for each signal pole from the Standard Foundations Chart (sheet M 8) based on the Design N-value and the predominant soil type. For each standard pole location, submit a completed "Metal Pole Standard Foundation Selection Form" signed by the Contractor's representative. Signature on form is for verification purposes only. Include the Design N-value calculation and resulting drilled pier length, "L," on each form.

If non-standard site-specific poles are shown on the plans, submit completed boring logs collected in accordance with Section 2 (Soil Test) above along with pole loading diagrams from the plans to the contractor-selected pole fabricator to assist in the pole and foundation design.

If one of the following occurs, the Standard Foundations Chart shown on the plans may not be used and a non-standard foundation may be required. In such case, contact the Engineer.

- The Design N-value is less than 4.
- The drilled pier length, "L", determined from the Standard Foundations Chart, is greater than the depth of the corresponding boring.

In the case where a standard foundation cannot be used, the Department will be responsible for the additional cost of the non-standard foundation.

Foundation designs are based on level ground around the traffic signal pole. If the slope around the edge of the drilled pier is steeper than 8:1 (H:V) or the proposed foundation will be less than 10 feet from the top of an embankment slope, the Contractor is responsible for providing slope information to the foundation designer and to the Engineer so it can be considered in the design.

The “Metal Pole Standard Foundation Selection Form” may be found at:

<http://www.ncdot.gov/doh/preconstruct/highway/geotech/formdet/misc/MetalPole.pdf>

If assistance is needed, contact the Engineer.

4. Non-Standard Foundation Design:

Design non-standard foundations based upon site-specific soil test information collected in accordance with Section 2 (Soil Test) above. Design drilled piers for side resistance only in accordance with Section 4.6 of the *AASHTO Standard Specifications for Highway Bridges*. Use the computer software LPILE version-6.0 or later manufactured by Ensoft, Inc. to analyze drilled piers. Use the computer software gINT V8i or later manufactured by Bentley Systems, Inc. with the current NCDOT gINT library and data template to produce SPT boring logs. Provide a drilled pier foundation for each pole with a length and diameter that result in a horizontal lateral movement of less than 1 inch at the top of the pier and a horizontal rotational movement of less than 1 inch at the edge of the pier. Contact the Engineer for pole loading diagrams for standard poles to be used for non-standard foundation designs. Submit any non-standard foundation designs including drawings, calculations, and soil boring logs to the Engineer for review and approval before construction.

C. Drilled Pier Construction:

Construct drilled pier foundations in accordance with the *Foundations and Anchor Rod Assemblies for Metal Poles* provision.

3.5. CUSTOM DESIGN OF TRAFFIC SIGNAL SUPPORTS

A. General:

Design traffic signal supports with foundations consisting of metal strain poles or metal poles with mast arms.

The lengths of the metal signal poles shown on the plans are estimated from available data for bid purposes. Determine the actual length of each pole from field measurements and adjusted cross-sections. Furnish the revised pole heights to the Engineer. Use all other dimensional requirements shown on the plans.

Ensure each pole includes an identification tag with information and location positions as defined on Metal Pole Standard Drawing Sheets M2, M3 and M4. All pole shaft tags must include the NCDOT Inventory number followed by the pole number shown on the traffic signal or ITS (non-signalized locations) plan.

Design all traffic signal support structures using the following 5th Edition AASHTO specifications:

- Design for a 50 year service life as recommended by Table 3-3.
- Use the wind pressure map developed from 3-second gust speeds, as provided in Article 3.8.
- Ensure signal support structures include natural wind gust loading and truck-induced gust loading in the fatigue design, as provided for in Articles 11.7.3 and 11.7.4, respectively. Designs need not consider periodic galloping forces.

- Assume the natural wind gust speed in North Carolina is 11.2 mph. For natural wind fatigue stress calculations, utilize a drag coefficient (C_d) computed for 11.2 mph wind velocity and not the basic wind speed velocity.
- Design for Category II fatigue, as provided for in Article 11.6, unless otherwise specified.
- Calculate all stresses using applicable equations from Section 5. The Maximum allowable stress ratios for all signal support designs are 0.9.
- Conform to article 10.4.2 and 11.8 for all deflection requirements.

Ensure that the design permits cables to be installed inside poles and mast arms.

Unless otherwise specified by special loading criteria, the computed surface area for ice load on signal heads is:

- 3-section, 12-inch, Surface area: 26.0 ft² (17.0 ft² without back plate)
- 4-section, 12-inch, Surface area: 32.0 ft² (21.0 ft² without back plate)
- 5-section, 12-inch, Surface area: 42.0 ft² (29.0 ft² without back plate)

The ice loading for signal heads defined above includes the additional surface area that back plates will induce. Special loading criteria may be specified in instances where back plates will not be installed on signal heads. Refer to the Loading Schedule on each Metal Pole Loading Diagram for revised signal head surface areas. The pole designer should revise ice loads accordingly in this instance. Careful examination of the plans when this is specified is important as this may impact sizing of the metal support structure and foundation design which could affect proposed bid quotes. All maximum stress ratios of 0.9 still apply.

Assume the combined minimum weight of a messenger cable bundle (including messenger cable, signal cable and detector lead-in cables) is 1.3 lbs/ft. Assume the combined minimum diameter of this cable bundle is 1.3 inches.

Ensure that designs provide a removable pole cap with stainless steel attachment screws for each pole top and mast arm end.

B. Metal Poles:

Submit design drawings for approval including pre-approved QPL pole drawings. Show all the necessary details and calculations for the metal poles including the foundation and connections. Include NCDOT inventory number on design drawings. Include as part of the design calculations the ASTM specification numbers for the materials to be used. Provide the types and sizes of welds on the design drawings. Include a Bill of Materials on design drawings. Ensure design drawings and calculations are signed, dated, and sealed by the responsible professional engineer licensed in the state of North Carolina. Immediately bring to the attention of the Engineer any structural deficiency that becomes apparent in any assembly or member of any assembly as a result of the design requirements imposed by these specifications, the plans, or the typical drawings. Said Professional Engineer is wholly responsible for the design of all poles and arms. Review and acceptance of these designs by the Department does not relieve the said Professional Engineer of his responsibility. **Do not fabricate the assemblies until receipt of the Department's approval of the design drawings.**

For mast arm poles, provide designs with provisions for pole plates and associated gussets and fittings for mast arm attachment. As part of each mast arm attachment, provide a grommeted 2"

diameter hole on the shaft side of the connection to allow passage of the signal cables from the pole to the arm.

Where ice is present, assume wind loads as shown in Figure 3-5 of the 5th Edition AASHTO Specification for Group III loading.

For each strain pole, provide two messenger cable clamps and associated hardware to attach the messenger support cable. Ensure that the diameter of the clamps is appropriately designed to be adjustable from 1'-6" inches below the top, down to 6'-6" below the top of the pole. Do not attach more than one messenger support cable to a messenger cable clamp.

Provide a grounding lug(s) in the approximate vicinity of the messenger cable clamp for bonding and grounding messenger cable. Lugs must accept #4 or #6 AWG wire to bond messenger cables to the pole in order to provide an effective ground fault circuit path. Refer to Metal Pole Standard Drawing Sheet M6 for construction details.

Design tapers for all pole shafts that begin at the base with diameters that decrease uniformly at the rate of 0.14 inch per foot of length.

Design a base plate on each pole. The minimum base plate thickness for all poles is determined by the following criteria:

Case 1 Circular or rectangular solid base plate with the upright pole welded to the top surface of base plate with full penetration butt weld, and where no stiffeners are provided. A base plate with a small center hole, which is less than 1/3 of the upright diameter, and located concentrically with the upright pole, may be considered as a solid base plate.

The magnitude of bending moment in the base plate, induced by the anchoring force of each anchor bolt is $M = (P \times D_1) / 2$, where

M = bending moment at the critical section of the base plate induced by one anchor bolt

P = anchoring force of each anchor bolt

D_1 = horizontal distance between the anchor bolt center and the outer face of the upright, or the difference between the bolt circle radius and the outside radius of the upright

Locate the critical section at the face of the anchor bolt and perpendicular to the bolt circle radius. The overlapped part of two adjacent critical sections is considered ineffective.

Case 2 Circular or rectangular base plate with the upright pole socketed into and attached to the base plate with two lines of fillet weld, and where no stiffeners are provided, or any base plate with a center hole that is larger in diameter than 1/3 of the upright diameter.

The magnitude of bending moment induced by the anchoring force of each anchor bolt is $M = P \times D_2$,

where P = anchoring force of each anchor bolt

D_2 = horizontal distance between the face of the upright and the face of the anchor bolt nut

Locate the critical section at the face of the anchor bolt top nut and perpendicular to the radius of the bolt circle. The overlapped part of two adjacent critical sections is considered ineffective.

If the base plate thickness calculated for Case 2 is less than Case 1, use the thickness calculated for Case 1.

The following additional owner requirements apply concerning pole base plates.

- Ensure that whichever case governs as defined above, the anchor bolt diameter is set to match the base plate thickness. If the minimum diameter required for the anchor bolt exceeds the thickness required for the base plate, set the base plate thickness equal to the required bolt diameter.
- For dual mast arm supports, or for single mast arm supports 50' or greater, use a minimum 8 bolt orientation with 2" diameter anchor bolts, and a 2" thick base plate.
- For all metal poles with mast arms, use a full penetration groove weld with a backing ring to connect the pole upright component to the base. Refer to Metal Pole Standard Drawing Sheet M4.

Ensure that designs have anchor bolt holes with a diameter 1/4 inch larger than the anchor bolt diameters in the base plate.

Ensure that the anchor bolts have the required diameters, lengths, and positions, and will develop strengths comparable to their respective poles.

Provide designs with a 6 x 12-inch hand hole with a reinforcing frame for each pole.

Provide designs with a terminal compartment with cover and screws in each pole that encompasses the hand hole and contains provisions for a 12-terminal barrier type terminal block.

For each pole, provide designs with provisions for a 1/2 inch minimum thread diameter, coarse thread stud and nut for grounding which will accommodate a #6 AWG ground wire. Ensure the lug is electrically bonded to the pole and is conveniently located inside the pole at the hand hole.

When required, design couplings on the pole for mounting pedestrian pushbuttons at a height of 42 inches above the bottom of the base. Provide mounting points consisting of 1-1/2 inch internally threaded half-couplings that comply with the NEC that are mounted within the poles. Ensure the couplings are essentially flush with the outside surfaces of the poles and are installed before any required galvanizing. Provide a threaded plug for each half coupling. Ensure that the surface of the plug is essentially flush with the outer end of the mounting point when installed and has a recessed hole to accommodate a standard wrench.

3.6. POLE NUMBERING SYSTEM

Attach an identification tag to each pole shaft and mast arm section as shown on Metal Pole Standard Drawing Sheet M2 "Typical Fabrication Details Common To All Metal Poles".

3.7. MEASUREMENT AND PAYMENT

Actual number of metal strain signal poles (without regard to height or load capacity) furnished, installed and accepted.

Actual number of soil tests with SPT borings drilled furnished and accepted.

Actual volume of concrete poured in cubic yards of drilled pier foundation furnished, installed and accepted.

No measurement will be made for foundation designs prepared with metal pole designs, as these will be considered incidental to designing signal support structures.

Payment will be made under:

Metal Strain Signal Pole	Each
Soil Test	Each
Drilled Pier Foundation.....	Cubic Yard

4. CONTROLLERS WITH CABINETS

4.1. MATERIALS – TYPE 2070L CONTROLLERS

Conform to CALTRANS *Transportation Electrical Equipment Specifications (TEES)* (dated August 16, 2002, plus Errata 1 dated October 27, 2003 and Errata 2 dated June 08, 2004) except as required herein.

Furnish Model 2070L controllers. Ensure that removal of the CPU module from the controller will place the intersection into flash.

The Department will provide software at the beginning of the burning-in period. Contractor shall give 5 working days notice before needing software. Program software provided by the Department.

Provide model 2070L controllers with the latest version of OS9 operating software and device drivers, composed of the unit chassis and at a minimum the following modules and assemblies:

- MODEL 2070 1B, CPU Module, Single Board
- MODEL 2070-2A, Field I/O Module (FI/O)
 - Note: Configure the Field I/O Module to disable both the External WDT Shunt/Toggle Switch and SP3 (SP3 active indicator is “off”)
- MODEL 2070-3B, Front Panel Module (FP), Display B (8x40)
- MODEL 2070-4A, Power Supply Module, 10 AMP
- MODEL 2070-7A, Async Serial Com Module (9-pin RS-232)

Furnish one additional MODEL 2070-7A, Async Serial Com Module (9-pin RS-232) for all master controller locations.

For each master location and central control center, furnish a U.S. Robotics V.92 or approved equivalent auto-dial/auto-answer external modem to accomplish the interface to the Department-furnished microcomputers. Include all necessary hardware to ensure telecommunications.

4.2. MATERIALS – GENERAL CABINETS

Provide a moisture resistant coating on all circuit boards.

Provide one 20 mm diameter radial lead UL-recognized metal oxide varistor (MOV) between each load switch field terminal and equipment ground. Electrical performance is outlined below.

PROPERTIES OF MOV SURGE PROTECTOR	
Maximum Continuous Applied Voltage at 185° F	150 VAC (RMS) 200 VDC
Maximum Peak 8x20µs Current at 185° F	6500 A
Maximum Energy Rating at 185° F	80 J
Voltage Range 1 mA DC Test at 77° F	212-268 V
Max. Clamping Voltage 8x20µs, 100A at 77° F	395 V
Typical Capacitance (1 MHz) at 77° F	1600 pF

Provide a power line surge protector that is a two-stage device that will allow connection of the radio frequency interference filter between the stages of the device. Ensure that a maximum continuous current is at least 10A at 120V. Ensure that the device can withstand a minimum of 20 peak surge current occurrences at 20,000A for an 8x20 microsecond waveform. Provide a maximum clamp voltage of 395V at 20,000A with a nominal series inductance of 200µh. Ensure that the voltage does not exceed 395V. Provide devices that comply with the following:

Frequency (Hz)	Minimum Insertion Loss (dB)
60	0
10,000	30
50,000	55
100,000	50
500,000	50
2,000,000	60
5,000,000	40
10,000,000	20
20,000,000	25

4.3. MATERIALS – TYPE 170E CABINETS

A. Type 170 E Cabinets General:

Conform to the city of Los Angeles' Specification No. 54-053-08, *Traffic Signal Cabinet Assembly Specification* (dated July 2008), except as required herein.

Furnish model 332 base mounted cabinets configured for 8 vehicle phases, 4 pedestrian phases, and 6 overlaps. When overlaps are required, provide auxiliary output files for the overlaps. Do not reassign load switches to accommodate overlaps unless shown on electrical details.

Provide model 200 load switches, model 222 loop detector sensors, model 252 AC isolators, and model 242 DC isolators according to the electrical details. As a minimum, provide one (1) model 2018 conflict monitor, one (1) model 206L power supply unit, two (2) model 204 flashers, one (1) DC isolator (located in slot I14), and four (4) model 430 flash transfer relays (provide seven (7) model 430 flash transfer relays if auxiliary output file is installed) with each cabinet.

B. Type 170 E Cabinet Electrical Requirements:

Provide a cabinet assembly designed to ensure that upon leaving any cabinet switch or conflict monitor initiated flashing operation, the controller starts up in the programmed start up phases and start up interval.

Furnish two sets of non-fading cabinet wiring diagrams and schematics in a paper envelope or container and placed in the cabinet drawer.

All AC+ power is subject to radio frequency signal suppression.

Provide surge suppression in the cabinet for each type of cabinet device. Provide surge protection for the full capacity of the cabinet input file. Provide surge suppression devices that operate properly over a temperature range of -40° F to +185° F. Ensure the surge suppression devices provide both common and differential modes of protection.

Provide a pluggable power line surge protector that is installed on the back of the PDA (power distribution assembly) chassis to filter and absorb power line noise and switching transients. Ensure the device incorporates LEDs for failure indication and provides a dry relay contact closure for the purpose of remote sensing. Ensure the device meets the following specifications:

- Peak Surge Current (Single pulse, 8x20µs).....20,000A
- Occurrences (8x20µs waveform).....10 minimum @ 20,000A
- Maximum Clamp Voltage.....395VAC
- Operating Current.....15 amps
- Response Time.....< 5 nanoseconds

Provide a loop surge suppressor for each set of loop terminals in the cabinet. Ensure the device meets the following specifications:

- Peak Surge Current (6 times, 8x20µs)
 - (Differential Mode).....400A
 - (Common Mode).....1,000A
- Occurrences (8x20µs waveform).....500 min @ 200A
- Maximum Clamp Voltage
 - (Differential Mode @400A).....35V
 - (Common Mode @1,000A).....35V
- Response Time.....< 5 nanoseconds
- Maximum Capacitance.....35 pF

Provide a data communications surge suppressor for each communications line entering or leaving the cabinet. Ensure the device meets the following specifications:

- Peak Surge Current (Single pulse, 8x20 μ s).....10,000A
- Occurrences (8x20 μ s waveform).....100 min @ 2,000A
- Maximum Clamp Voltage.....Rated for equipment protected
- Response Time.....< 1 nanosecond
- Maximum Capacitance.....1,500 pF
- Maximum Series Resistance.....15 Ω

Provide a DC signal surge suppressor for each DC input channel in the cabinet. Ensure the device meets the following specifications:

- Peak Surge Current (Single pulse, 8x20 μ s).....10,000A
- Occurrences (8x20 μ s waveform).....100 @ 2,000A
- Maximum Clamp Voltage.....30V
- Response Time.....< 1 nanosecond

Provide a 120 VAC signal surge suppressor for each AC+ interconnect signal input. Ensure the device meets the following specifications:

- Peak Surge Current (Single pulse, 8x20 μ s).....20,000A
- Maximum Clamp Voltage.....350VAC
- Response Time.....< 200 nanoseconds
- Discharge Voltage.....<200 Volts @ 1,000A
- Insulation Resistance..... \geq 100 M Ω

Provide conductors for surge protection wiring that are of sufficient size (ampacity) to withstand maximum overcurrents which could occur before protective device thresholds are attained and current flow is interrupted.

If additional surge protected power outlets are needed to accommodate fiber transceivers, modems, etc., install a UL listed, industrial, heavy-duty type power outlet strip with a minimum rating of 15 A / 125 VAC, 60 Hz. Provide a strip that has a minimum of 3 grounded outlets. Ensure the power outlet strip plugs into one of the controller unit receptacles located on the rear of the PDA. Ensure power outlet strip is mounted securely; provide strain relief if necessary.

Provide a door switch in the front and a door switch in the rear of the cabinet that will provide the controller unit with a Door Ajar alarm when either the front or the rear door is open. Ensure the door switches apply DC ground to the Input File when either the front door or the rear door is open.

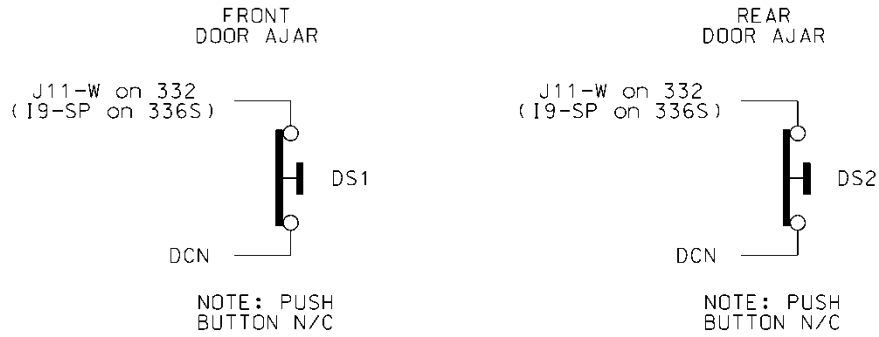

Furnish a fluorescent fixture in the rear across the top of the cabinet and another fluorescent fixture in the front across the top of the cabinet at a minimum. Ensure that the fixtures provide sufficient light to illuminate all terminals, labels, switches, and devices in the cabinet. Conveniently locate the fixtures so as not to interfere with a technician’s ability to perform work on any devices or terminals in the cabinet. Provide a protective diffuser to cover exposed bulbs. Install 16 watt T-4 lamps in the fluorescent fixtures. Provide a door switch to provide power to each fixture when the respective door is open. Wire the fluorescent fixtures to the 15 amp ECB (equipment circuit breaker).

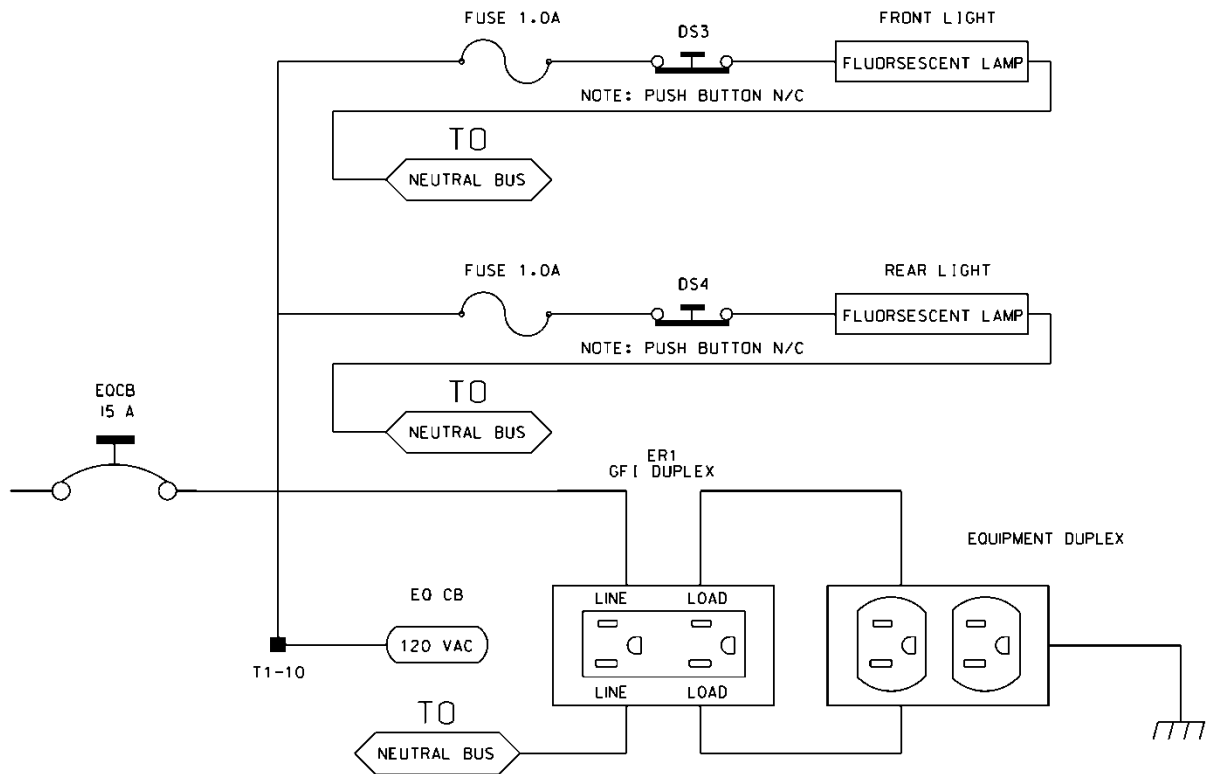

Furnish a police panel with a police panel door. Ensure that the police panel door permits access to the police panel when the main door is closed. Ensure that no rainwater can enter the cabinet even with the police panel door open. Provide a police panel door hinged on the right side as viewed from the front. Provide a police panel door lock that is keyed to a standard police/fire call box key. In addition to the requirements of LA Specification No. 54-053-08, provide the police panel with a

toggle switch connected to switch the intersection operation between normal stop-and-go operation (AUTO) and manual operation (MANUAL). Ensure that manual control can be implemented using inputs and software such that the controller provides full programmed clearance times for the yellow clearance and red clearance for each phase while under manual control.

Provide a 1/4-inch locking phone jack in the police panel for a hand control to manually control the intersection. Provide sufficient room in the police panel for storage of a hand control and cord.

For model 332 base mounted cabinets, ensure terminals J14-E and J14-K are wired together on the rear of the Input File. Connect TB9-12 (J14 Common) on the Input Panel to T1-2 (AC-) on the rear of the PDA.

Provide detector test switches mounted at the top of the cabinet rack or other convenient location which may be used to place a call on each of eight phases based on the chart below. Provide three positions for each switch: On (place call), Off (normal detector operation), and Momentary On (place momentary call and return to normal detector operation after switch is released). Ensure that the switches are located such that the technician can read the controller display and observe the intersection.

Connect detector test switches for cabinets as follows:

332 Cabinet	
Detector Call Switches	Terminals
Phase 1	I1-W
Phase 2	I4-W
Phase 3	I5-W
Phase 4	I8-W
Phase 5	J1-W
Phase 6	J4-W
Phase 7	J5-W
Phase 8	J8-W

Provide the PCB 28/56 connector for the conflict monitor unit (CMU) with 28 independent contacts per side, dual-sided with 0.156 inch contact centers. Provide the PCB 28/56 connector contacts with solder eyelet terminations. Ensure all connections to the PCB 28/56 connector are soldered to the solder eyelet terminations.

Ensure that all cabinets have the CMU connector wired according to the 332 cabinet connector pin assignments (include all wires for auxiliary output file connection). Wire pins 13, 16, R, and U of the CMU connector to a separate 4 pin plug, P1, as shown below. Provide a second plug, P2, which will mate with P1 and is wired to the auxiliary output file as shown below. Provide an additional plug, P3, which will mate with P1 and is wired to the pedestrian yellow circuits as shown below. When no auxiliary output file is installed in the cabinet, provide wires for the green and yellow inputs for channels 11, 12, 17, and 18, the red inputs for channels 17 and 18, and the wires

for the P2 plug. Terminate the two-foot wires with ring type lugs, insulated, and bundled for optional use.

P1			P2		P3	
PIN	FUNCTION	CONN TO	FUNCTION	CONN TO	FUNCTION	CONN TO
1	CH-9G	CMU-13	OLA-GRN	A123	2P-YEL	114
2	CH-9Y	CMU-16	OLA-YEL	A122	4P-YEL	105
3	CH-10G	CMU-R	OLB-GRN	A126	6P-YEL	120
4	CH-10Y	CMU-U	OLB-YEL	A125	8P-YEL	111

Do not provide the P20 terminal assembly (red monitor board) or red interface ribbon cable as specified in LA Specification No. 54-053-08.

Provide a P20 connector that mates with and is compatible with the red interface connector mounted on the front of the conflict monitor. Ensure that the P20 connector and the red interface connector on the conflict monitor are center polarized to ensure proper connection. Ensure that removal of the P20 connector will cause the conflict monitor to recognize a latching fault condition and place the cabinet into flashing operation.

Wire the P20 connector to the output file and auxiliary output file using 22 AWG stranded wires. Ensure the length of these wires is a minimum of 42 inches in length. Provide a durable braided sleeve around the wires to organize and protect the wires.

Wire the P20 connector to the traffic signal red displays to provide inputs to the conflict monitor as shown below. Ensure the pedestrian Don't Walk circuits are wired to channels 13 through 16 of the P20 connector. When no auxiliary output file is installed in the cabinet, provide wires for channels 9 through 12 reds. Provide a wire for special function 1. Terminate the unused wires with ring type lugs, insulated, and bundled for optional use.

P20 Connector					
PIN	FUNCTION	CONN TO	PIN	FUNCTION	CONN TO
1	Channel 15 Red	119	2	Channel 16 Red	110
3	Channel 14 Red	104	4	Chassis GND	01-9
5	Channel 13 Red	113	6	N/C	
7	Channel 12 Red	AUX 101	8	Spec Function 1	
9	Channel 10 Red	AUX 124	10	Channel 11 Red	AUX 114
11	Channel 9 Red	AUX 121	12	Channel 8 Red	107
13	Channel 7 Red	122	14	Channel 6 Red	134
15	Channel 5 Red	131	16	Channel 4 Red	101
17	Channel 3 Red	116	18	Channel 2 Red	128
19	Channel 1 Red	125	20	Red Enable	01-14

Ensure the controller unit outputs to the auxiliary output file are pre-wired to the C5 connector. When no auxiliary output file is installed in the cabinet, connect the C5 connector to a storage socket located on the Input Panel or on the rear of the PDA.

Do not wire pin 12 of the load switch sockets.

In addition to the requirements of LA Specification No. 54-053-08, ensure relay K1 on the Power Distribution Assembly (PDA) is a four pole relay and K2 on the PDA is a two pole relay.

Provide a two pole, ganged circuit breaker for the flash bus circuit. Ensure the flash bus circuit breaker is an inverse time circuit breaker rated for 10 amps at 120 VAC with a minimum of 10,000 RMS symmetrical amperes short circuit current rating. Do not provide the auxiliary switch feature on the flash bus circuit breaker. Ensure the ganged flash bus circuit breaker is certified by the circuit breaker manufacturer to provide gang tripping operation.

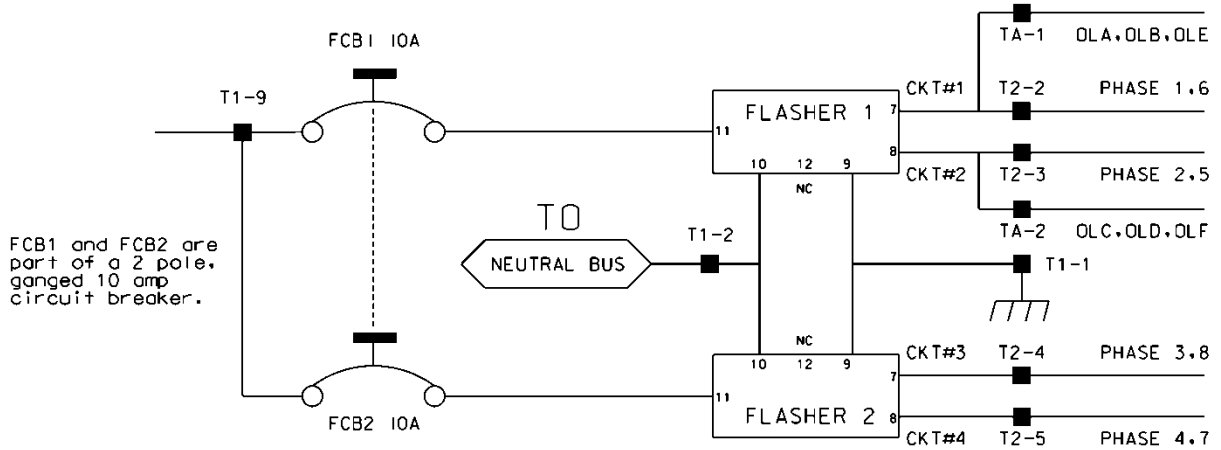

Ensure auxiliary output files are wired as follows:

AUXILIARY OUTPUT FILE	
TERMINAL BLOCK TA ASSIGNMENTS	
POSITION	FUNCTION
1	Flasher Unit #1, Circuit 1/FTR1 (OLA, OLB)/FTR3 (OLE)
2	Flasher Unit #1, Circuit 2/FTR2 (OLC, OLD)/FTR3 (OLF)
3	Flash Transfer Relay Coils
4	AC -
5	Power Circuit 5
6	Power Circuit 5
7	Equipment Ground Bus
8	NC

Provide four spare load resistors mounted in each cabinet. Ensure each load resistor is rated as shown in the table below. Wire one side of each load resistor to AC-. Connect the other side of each resistor to a separate terminal on a four (4) position terminal block. Mount the load resistors

and terminal block either inside the back of Output File No. 1 or on the upper area of the Service Panel.

ACCEPTABLE LOAD RESISTOR VALUES	
VALUE (ohms)	WATTAGE
1.5K – 1.9 K	25W (min)
2.0K – 3.0K	10W (min)

Provide Model 200 load switches, Model 204 flashers, Model 242 DC isolators, Model 252 AC isolators, and Model 206L power supply units that conform to CALTRANS' *Transportation Electrical Equipment Specifications* dated March 12, 2009 with Erratum 1.

C. Type 170 E Cabinet Physical Requirements:

Do not mold, cast, or scribe the name "City of Los Angeles" on the outside of the cabinet door as specified in LA Specification No. 54-053-08. Do not provide a Communications Terminal Panel as specified in LA Specification No. 54-053-08. Do not provide terminal block TBB on the Service Panel. Do not provide Cabinet Verification Test Program software or associated test jigs as specified in LA Specification No. 54-053-08.

Furnish unpainted, natural, aluminum cabinet shells. Ensure that all non-aluminum hardware on the cabinet is stainless steel or a Department approved non-corrosive alternate.

Ensure the lifting eyes, gasket channels, police panel, and all supports welded to the enclosure and doors are fabricated from 0.125 inch minimum thickness aluminum sheet and meet the same standards as the cabinet and doors.

Provide front and rear doors with latching handles that allow padlocking in the closed position. Furnish 0.75 inch minimum diameter stainless steel handles with a minimum 0.5 inch shank. Place the padlocking attachment at 4.0 inches from the handle shank center to clear the lock and key. Provide an additional 4.0 inches minimum gripping length.

Provide Corbin #2 locks on the front and rear doors. Provide one (1) Corbin #2 and one (1) police master key with each cabinet. Ensure main door locks allow removal of keys in the locked position only.

Provide a surge protection panel with 16 loop surge protection devices and designed to allow sufficient free space for wire connection/disconnection and surge protection device replacement. For model 332 cabinets, provide an additional 20 loop surge protection devices. Provide an additional two AC+ interconnect surge devices to protect one slot and eight DC surge protection devices to protect four slots. Provide no protection devices on slot I14.

For base mounted cabinets, mount surge protection panels on the left side of the cabinet as viewed from the rear. Attach each panel to the cabinet rack assembly using bolts and make it easily removable. Mount the surge protection devices in vertical rows on each panel and connect the devices to one side of 12 position, double row terminal blocks with #8 screws. For each surge protection panel, terminate all grounds from the surge protection devices on a copper equipment

ground bus attached to the surge protection panel. Wire the terminals to the rear of a standard input file using spade lugs for input file protection.

Provide permanent labels that indicate the slot and the pins connected to each terminal that may be viewed from the rear cabinet door. Label and orient terminals so that each pair of inputs is next to each other. Indicate on the labeling the input file (I or J), the slot number (1-14) and the terminal pins of the input slots (either D & E for upper or J & K for lower).

Provide a minimum 14 x 16 inch pull out, hinged top shelf located immediately below controller mounting section of the cabinet. Ensure the shelf is designed to fully expose the table surface outside the controller at a height approximately even with the bottom of the controller. Ensure the shelf has a storage bin interior which is a minimum of 1 inch deep and approximately the same dimensions as the shelf. Provide an access to the storage area by lifting the hinged top of the shelf. Fabricate the shelf and slide from aluminum or stainless steel and ensure the assembly can support the 2070L controller plus 15 pounds of additional weight. Ensure shelf has a locking mechanism to secure it in the fully extended position and does not inhibit the removal of the 2070L controller or removal of cards inside the controller when fully extended. Provide a locking mechanism that is easily released when the shelf is to be returned to its non-use position directly under the controller.

D. Model 2018 Enhanced Conflict Monitor:

Furnish Model 2018 Enhanced Conflict Monitors that provide monitoring of 18 channels. Ensure each channel consists of a green, yellow, and red field signal input. Ensure that the conflict monitor meets or exceeds CALTRANS' Transportation Electrical Equipment Specifications dated March 12, 2009, with Erratum 1 (hereafter referred to as CALTRANS' 2009 TEES) for a model 210 monitor unit and other requirements stated in this specification.

Ensure the conflict monitor is provided with an 18 channel conflict programming card. Pin EE and Pin T of the conflict programming card shall be connected together. Pin 16 of the conflict programming card shall be floating. Ensure that the absence of the conflict programming card will cause the conflict monitor to trigger (enter into fault mode), and remain in the triggered state until the programming card is properly inserted and the conflict monitor is reset.

Provide a conflict monitor that incorporates LED indicators into the front panel to dynamically display the status of the monitor under normal conditions and to provide a comprehensive review of field inputs with monitor status under fault conditions. Ensure that the monitor indicates the channels that were active during a conflict condition and the channels that experienced a failure for all other per channel fault conditions detected. Ensure that these indications and the status of each channel are retained until the Conflict Monitor is reset. Furnish LED indicators for the following:

- AC Power (Green LED indicator)
- VDC Failed (Red LED indicator)
- WDT Error (Red LED indicator)
- Conflict (Red LED indicator)
- Red Fail (Red LED indicator)
- Dual Indication (Red LED indicator)
- Yellow/Clearance Failure (Red LED indicator)

- PCA/PC Ajar (Red LED indicator)
- Monitor Fail/Diagnostic Failure (Red LED indicator)
- 54 Channel Status Indicators (1 Red, 1 Yellow, and 1 Green LED indicator for each of the 18 channels)

Provide a switch to set the Red Fail fault timing. Ensure that when the switch is in the ON position the Red Fail fault timing value is set to 1350 +/- 150ms (2018 mode). Ensure that when the switch is in the OFF position the Red Fail fault timing value is set to 850 +/- 150ms (210 mode).

Provide a switch to set the Watchdog fault timing. Ensure that when the switch is in the ON position the Watchdog fault timing value is set to 1.0 +/- 0.1s (2018 mode). Ensure that when the switch is in the OFF position the Watchdog fault timing value is set to 1.5 +/- 0.1s (210 mode).

Provide a jumper or switch to set the AC line brown-out levels. Ensure that when the jumper is present or the switch is in the ON position the AC line dropout voltage threshold is 98 +/- 2 Vrms, the AC line restore voltage threshold is 103 +/- 2 Vrms, and the AC line brown-out timing value is set to 400 +/- 50ms (2018 mode). Ensure that when the jumper is not present or the switch is in the OFF position the AC line dropout voltage threshold is 92 +/- 2 Vrms, the AC line restore voltage threshold is 98 +/- 2 Vrms, and the AC line brown-out timing value is set to 80 +/- 17ms (210 mode).

Provide a jumper or switch that will enable and disable the Watchdog Latch function. Ensure that when the jumper is not present or the switch is in the OFF position the Watchdog Latch function is disabled. In this mode of operation, a Watchdog fault will be reset following a power loss, brownout, or power interruption. Ensure that when the jumper is present or the switch is in the ON position the Watchdog Latch function is enabled. In this mode of operation, a Watchdog fault will be retained until a Reset command is issued.

Provide a jumper that will reverse the active polarity for pin #EE (output relay common). Ensure that when the jumper is not present pin #EE (output relay common) will be considered 'Active' at a voltage greater than 70 Vrms and 'Not Active' at a voltage less than 50 Vrms (Caltrans mode). Ensure that when the jumper is present pin #EE (output relay common) will be considered 'Active' at a voltage less than 50 Vrms and 'Not Active' at a voltage greater than 70 Vrms (Failsafe mode).

In addition to the connectors required by CALTRANS' 2009 TEES, provide the conflict monitor with a red interface connector mounted on the front of the monitor. Ensure the connector is a 20 pin, right angle, center polarized, male connector with latching clip locks and polarizing keys. Ensure the right angle solder tails are designed for a 0.062" thick printed circuit board. Keying of the connector shall be between pins 3 and 5, and between 17 and 19. Ensure the connector has two rows of pins with the odd numbered pins on one row and the even pins on the other row. Ensure the connector pin row spacing is 0.10" and pitch is 0.10". Ensure the mating length of the connector pins is 0.24". Ensure the pins are finished with gold plating 30μ" thick.

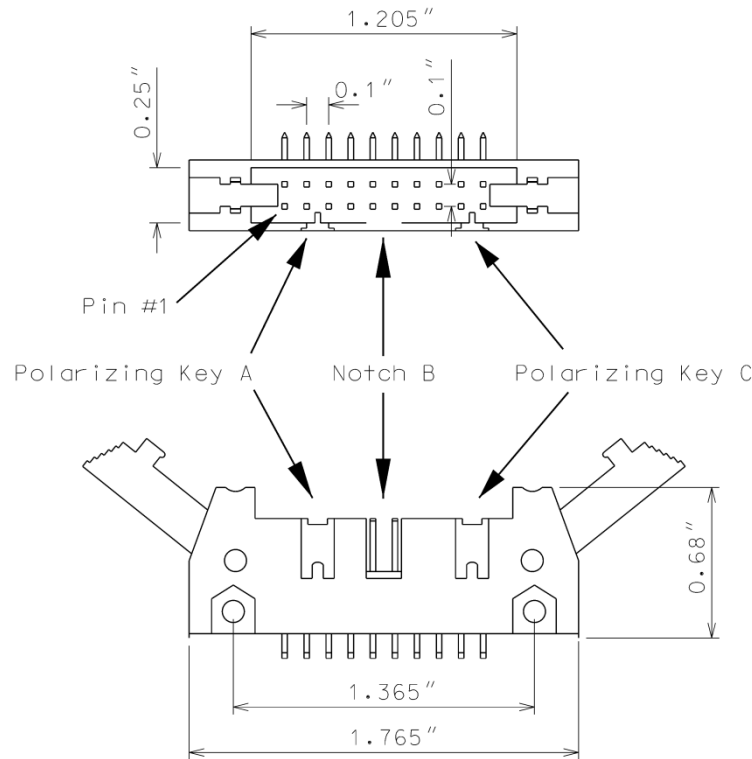

Ensure the red interface connector pins on the monitor have the following functions:

Pin #	Function	Pin #	Function
1	Channel 15 Red	2	Channel 16 Red
3	Channel 14 Red	4	Chassis Ground
5	Channel 13 Red	6	Special Function 2
7	Channel 12 Red	8	Special Function 1
9	Channel 10 Red	10	Channel 11 Red
11	Channel 9 Red	12	Channel 8 Red
13	Channel 7 Red	14	Channel 6 Red
15	Channel 5 Red	16	Channel 4 Red
17	Channel 3 Red	18	Channel 2 Red
19	Channel 1 Red	20	Red Enable

Ensure that removal of the P20 cable connector will cause the conflict monitor to recognize a latching fault condition and place the cabinet into flashing operation.

Provide Special Function 1 and Special Function 2 inputs to the unit which shall disable only Red Fail Monitoring when either input is sensed active. A Special Function input shall be sensed active when the input voltage exceeds 70 Vrms with a minimum duration of 550 ms. A Special Function input shall be sensed not active when the input voltage is less than 50 Vrms or the duration is less than 250 ms. A Special Function input is undefined by these specifications and may or may not be

sensed active when the input voltage is between 50 Vrms and 70 Vrms or the duration is between 250 ms and 550 ms.

Ensure the conflict monitor recognizes field signal inputs for each channel that meet the following requirements:

- consider a Red input greater than 70 Vrms and with a duration of at least 500 ms as an “on” condition;
- consider a Red input less than 50 Vrms or with a duration of less than 200 ms as an “off” condition (no valid signal);
- consider a Red input between 50 Vrms and 70 Vrms or with a duration between 200 ms and 500 ms to be undefined by these specifications;
- consider a Green or Yellow input greater than 25 Vrms and with a duration of at least 500 ms as an “on” condition;
- consider a Green or Yellow input less than 15 Vrms or with a duration of less than 200 ms as an “off” condition; and
- consider a Green or Yellow input between 15 Vrms and 25 Vrms or with a duration between 200 ms and 500 ms to be undefined by these specifications.

Provide a conflict monitor that recognizes the faults specified by CALTRANS’ 2009 TEES and the following additional faults. Ensure the conflict monitor will trigger upon detection of a fault and will remain in the triggered (in fault mode) state until the unit is reset at the front panel or through the external remote reset input for the following failures:

1. **Red Monitoring or Absence of Any Indication (Red Failure):** A condition in which no “on” voltage signal is detected on any of the green, yellow, or red inputs to a given monitor channel. If a signal is not detected on at least one input (R, Y, or G) of a conflict monitor channel for a period greater than 1000 ms when used with a 170 controller and 1500 ms when used with a 2070L controller, ensure monitor will trigger and put the intersection into flash. If the absence of any indication condition lasts less than 750 ms when used with a 170 controller and 1200 ms when used with a 2070L controller, ensure conflict monitor will not trigger. Red fail monitoring shall be enabled on a per channel basis by the use of switches located on the conflict monitor. Have red monitoring occur when all of the following input conditions are in effect:
 - a) Red Enable input to monitor is active (Red Enable voltages are “on” at greater than 70 Vrms, off at less than 50 Vrms, undefined between 50 and 70 Vrms), and
 - b) Neither Special Function 1 nor Special Function 2 inputs are active.
 - c) Pin #EE (output relay common) is not active
2. **Short/Missing Yellow Indication Fault (Clearance Error):** Yellow indication following a green is missing or shorter than 2.7 seconds (with ± 0.1 -second accuracy). If a channel fails to detect an “on” signal at the Yellow input for a minimum of 2.7 seconds (± 0.1 second) following the detection of an “on” signal at a Green input for that channel, ensure that the monitor triggers and generates a clearance/short yellow error fault indication. Short/missing yellow (clearance) monitoring shall be enabled on a per channel basis by the use of switches located on the conflict monitor. This fault shall not occur when the channel is programmed

for Yellow Inhibit, when the Red Enable signal is inactive or pin #EE (output relay common) is active.

3. **Dual Indications on the Same Channel:** In this condition, more than one indication (R,Y,G) is detected as “on” at the same time on the same channel. If dual indications are detected for a period greater than 500 ms, ensure that the conflict monitor triggers and displays the proper failure indication (Dual Ind fault). If this condition is detected for less than 200 ms, ensure that the monitor does not trigger. G-Y-R dual indication monitoring shall be enabled on a per channel basis by the use of switches located on the conflict monitor. G-Y dual indication monitoring shall be enabled for all channels by use of a switch located on the conflict monitor. This fault shall not occur when the Red Enable signal is inactive or pin #EE (output relay common) is active.
4. **Configuration Settings Change:** The configuration settings are comprised of (as a minimum) the permissive diode matrix, dual indication switches, yellow disable jumpers, any option switches, any option jumpers, and the Watchdog Enable switch. Ensure the conflict monitor compares the current configuration settings with the previous stored configuration settings on power-up, on reset, and periodically during operation. If any of the configuration settings are changed, ensure that the conflict monitor triggers and causes the program card indicator to flash. Ensure that configuration change faults are only reset by depressing and holding the front panel reset button for a minimum of three seconds. Ensure the external remote reset input does not reset configuration change faults.

Ensure the conflict monitor will trigger and the AC Power indicator will flash at a rate of $2 \text{ Hz} \pm 20\%$ with a 50% duty cycle when the AC Line voltage falls below the “drop-out” level. Ensure the conflict monitor will resume normal operation when the AC Line voltage returns above the “restore” level. Ensure the AC Power indicator will remain illuminated when the AC voltage returns above the “restore” level. Should an AC Line power interruption occur while the monitor is in the fault mode, then upon restoration of AC Line power, the monitor will remain in the fault mode and the correct fault and channel indicators will be displayed.

Provide a flash interval of at least 6 seconds and at most 10 seconds in duration following a power-up, an AC Line interruption, or a brownout restore. Ensure the conflict monitor will suspend all fault monitoring functions, close the Output relay contacts, and flash the AC indicator at a rate of $4 \text{ Hz} \pm 20\%$ with a 50% duty cycle during this interval. Ensure the termination of the flash interval after at least 6 seconds if the Watchdog input has made 5 transitions between the True and False state and the AC Line voltage is greater than the “restore” level. If the watchdog input has not made 5 transitions between the True and False state within 10 ± 0.5 seconds, the monitor shall enter a WDT error fault condition.

Ensure the conflict monitor will monitor an intersection with a minimum of four approaches using the four-section Flashing Yellow Arrow (FYA) vehicle traffic signal as outlined by the NCHRP 3-54 research project for protected-permissive left turn signal displays. Ensure the conflict monitor will operate in the FYA mode and FYAc (Compact) mode as specified below to monitor each channel for the following fault conditions: Conflict, Red Fail, Dual Indication, and Clearance. Provide a switch to select between the FYA mode and FYAc mode. Provide a switch to select each FYA phase movement for monitoring.

FYA mode

FYA Signal Head	Phase 1	Phase 3	Phase 5	Phase 7
Red Arrow	Channel 9 Red	Channel 10 Red	Channel 11 Red	Channel 12 Red
Yellow Arrow	Channel 9 Yellow	Channel 10 Yellow	Channel 11 Yellow	Channel 12 Yellow
Flashing Yellow Arrow	Channel 9 Green	Channel 10 Green	Channel 11 Green	Channel 12 Green
Green Arrow	Channel 1 Green	Channel 3 Green	Channel 5 Green	Channel 7 Green

FYAc mode

FYA Signal Head	Phase 1	Phase 3	Phase 5	Phase 7
Red Arrow	Channel 1 Red	Channel 3 Red	Channel 5 Red	Channel 7 Red
Yellow Arrow	Channel 1 Yellow	Channel 3 Yellow	Channel 5 Yellow	Channel 7 Yellow
Flashing Yellow Arrow	Channel 1 Green	Channel 3 Green	Channel 5 Green	Channel 7 Green
Green Arrow	Channel 9 Green	Channel 9 Yellow	Channel 10 Green	Channel 10 Yellow

Ensure that the conflict monitor will log at least nine of the most recent events detected by the monitor in non-volatile EEPROM memory (or equivalent). For each event, record at a minimum the time, date, type of event, status of each field signal indication with RMS voltage, and specific channels involved with the event. Ensure the conflict monitor will log the following events: monitor reset, configuration, previous fault, and AC line. Furnish the signal sequence log that shows all channel states (Greens, Yellows, and Reds) and the Red Enable State for a minimum of 2 seconds prior to the current fault trigger point. Ensure the display resolution of the inputs for the signal sequence log is not greater than 50 ms.

For conflict monitors used within an Ethernet communications system, provide a conflict monitor with an Ethernet 10/100 Mbps, RJ-45 port for data communication access to the monitor by a local notebook computer and remotely via a workstation or notebook computer device connected to the signal system local area network. The Ethernet port shall be electrically isolated from the conflict monitor's electronics and shall provide a minimum of 1500 Vrms isolation. Integrate monitor with Ethernet network in cabinet. Provide software to retrieve the time and date from a network server in order to synchronize the on-board times between the conflict monitor and the

controller. Furnish and install the following Windows based, graphic user interface software on workstations and notebook computers where the signal system client software is installed: 1) software to view and retrieve all event log information, 2) software that will search and display a list of conflict monitor IP addresses and IDs on the network, and 3) software to change the conflict monitor's network parameters such as IP address and subnet mask.

For non-Ethernet connected monitors, provide a RS-232C/D compliant port (DB-9 female connector) on the front panel of the conflict monitor in order to provide communications from the conflict monitor to the 170/2070L controller or to a Department-furnished laptop computer. Electrically isolate the port interface electronics from all monitor electronics, excluding Chassis Ground. Ensure that the controller can receive all event log information through a controller Asynchronous Communications Interface Adapter (Type 170E) or Async Serial Comm Module (2070). Furnish and connect a serial cable from the conflict monitor's DB-9 connector to Comm Port 1 of the 2070 controller. Ensure conflict monitor communicates with the controller. Provide a Windows based graphic user interface software to communicate directly through the same monitor RS-232C/D compliant port to retrieve and view all event log information to a Department-furnished laptop computer. The RS-232C/D compliant port on the monitor shall allow the monitor to function as a DCE device with pin connections as follows:

Conflict Monitor RS-232C/D (DB-9 Female) Pinout		
Pin Number	Function	I/O
1	DCD	O
2	TX Data	O
3	RX Data	I
4	DTR	I
5	Ground	-
6	DSR	O
7	CTS	I
8	RTS	O
9	NC	-

MONITOR BOARD EDGE CONNECTOR

Pin #	Function (Back Side)	Pin #	Function (Component Side)
1	Channel 2 Green	A	Channel 2 Yellow
2	Channel 13 Green	B	Channel 6 Green
3	Channel 6 Yellow	C	Channel 15 Green
4	Channel 4 Green	D	Channel 4 Yellow
5	Channel 14 Green	E	Channel 8 Green
6	Channel 8 Yellow	F	Channel 16 Green
7	Channel 5 Green	H	Channel 5 Yellow
8	Channel 13 Yellow	J	Channel 1 Green
9	Channel 1 Yellow	K	Channel 15 Yellow
10	Channel 7 Green	L	Channel 7 Yellow
11	Channel 14 Yellow	M	Channel 3 Green
12	Channel 3 Yellow	N	Channel 16 Yellow
13	Channel 9 Green	P	Channel 17 Yellow
14	Channel 17 Green	R	Channel 10 Green
15	Channel 11 Yellow	S	Channel 11 Green
16	Channel 9 Yellow	T	Channel 18 Yellow
17	Channel 18 Green	U	Channel 10 Yellow
--		--	
18	Channel 12 Yellow	V	Channel 12 Green
19	Channel 17 Red	W	Channel 18 Red
20	Chassis Ground	X	Not Assigned
21	AC-	Y	DC Common
22	Watchdog Timer	Z	External Test Reset
23	+24VDC	AA	+24VDC
24	Tied to Pin 25	BB	Stop Time (Output)
25	Tied to Pin 24	CC	Not Assigned
26	Not Assigned	DD	Not Assigned
27	Relay Output, Side #3, N.O.	EE	Relay Output, Side #2, Common
28	Relay Output, Side #1, N.C.	FF	AC+

-- Slotted for keying between Pins 17/U and 18/V

CONFLICT PROGRAM CARD PIN ASSIGNMENTS

Pin #	Function (Back Side)	Pin #	Function (Component Side)
1	Channel 2 Green	A	Channel 1 Green
2	Channel 3 Green	B	Channel 2 Green
3	Channel 4 Green	C	Channel 3 Green
4	Channel 5 Green	D	Channel 4 Green
5	Channel 6 Green	E	Channel 5 Green
6	Channel 7 Green	F	Channel 6 Green
7	Channel 8 Green	H	Channel 7 Green
8	Channel 9 Green	J	Channel 8 Green
9	Channel 10 Green	K	Channel 9 Green
10	Channel 11 Green	L	Channel 10 Green
11	Channel 12 Green	M	Channel 11 Green
12	Channel 13 Green	N	Channel 12 Green
13	Channel 14 Green	P	Channel 13 Green
14	Channel 15 Green	R	Channel 14 Green
15	Channel 16 Green	S	Channel 15 Green
16	N/C	T	PC AJAR
17	Channel 1 Yellow	U	Channel 9 Yellow
18	Channel 2 Yellow	V	Channel 10 Yellow
19	Channel 3 Yellow	W	Channel 11 Yellow
20	Channel 4 Yellow	X	Channel 12 Yellow
21	Channel 5 Yellow	Y	Channel 13 Yellow
22	Channel 6 Yellow	Z	Channel 14 Yellow
23	Channel 7 Yellow	AA	Channel 15 Yellow
24	Channel 8 Yellow	BB	Channel 16 Yellow
--		--	
25	Channel 17 Green	CC	Channel 17 Yellow
26	Channel 18 Green	DD	Channel 18 Yellow
27	Channel 16 Green	EE	PC AJAR (Program Card)
28	Yellow Inhibit Common	FF	Channel 17 Green

-- Slotted for keying between Pins 24/BB and 25/CC

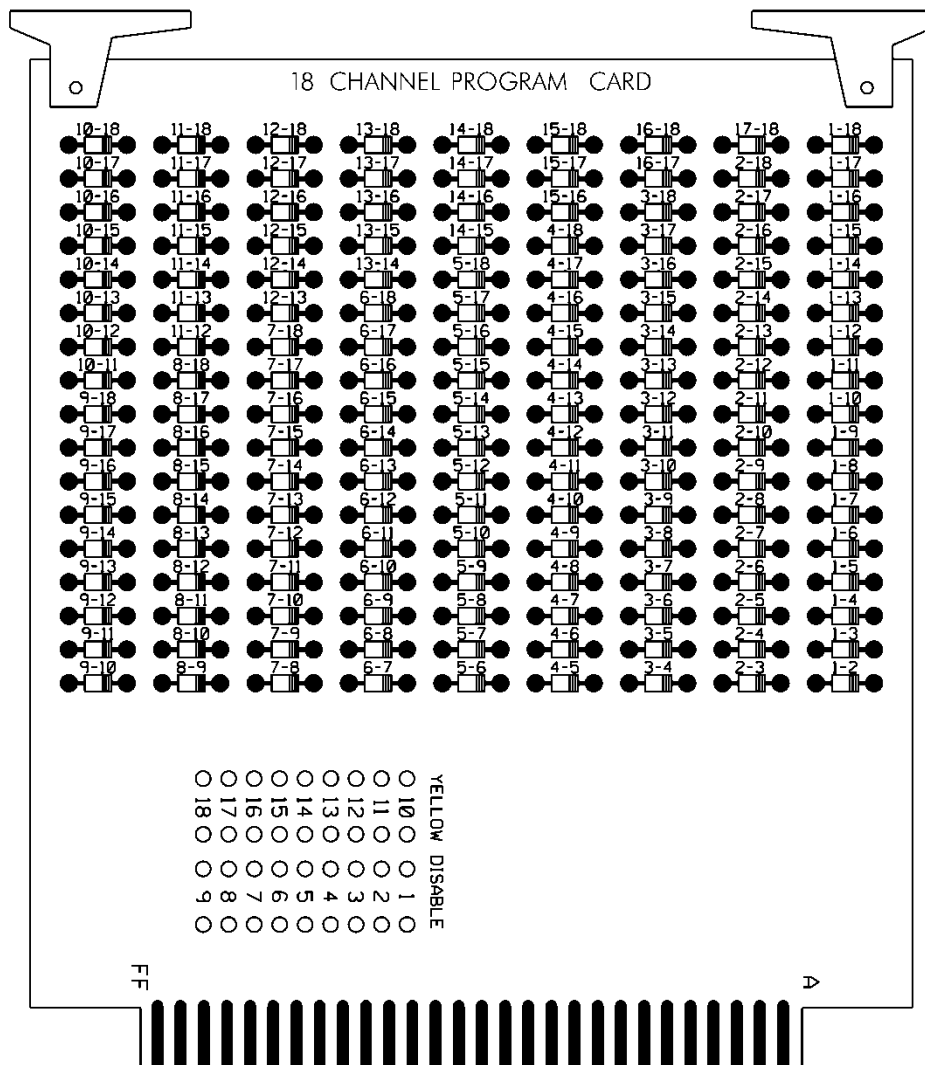

4.4. MATERIALS – TYPE 2070E CONTROLLERS

Conform to CALTRANS *Transportation Electrical Equipment Specifications (TEES)* (dated March 12, 2009, plus Errata 1 dated January 21, 2010) except as required herein.

Furnish Model 2070E controllers. Ensure that removal of the CPU module from the controller will place the intersection into flash.

The Department will provide software at the beginning of the burning-in period. Contractor shall give 5 working days notice before needing software. Program software provided by the Department.

Provide Model 2070E controllers with the latest version of OS9 operating software and device drivers, composed of the unit chassis and at a minimum the following modules and assemblies:

- MODEL 2070-1E, CPU Module, Single Board, with 8Mb Datakey (blue in color)
- MODEL 2070-2A or approved MODEL 2070-2E, Field I/O Module (FI/O)
 - Note: Configure the Field I/O Module to disable both the External WDT Shunt/Toggle Switch and SP3 (SP3 active indicator is “off”)
- MODEL 2070-3B, Front Panel Module (FP), Display B (8x40)

- MODEL 2070-4, Power Supply Module, 10 AMP
- MODEL 2070-7A, Async Serial Com Module (9-pin RS-232)

Furnish one additional MODEL 2070-7A, Async Serial Com Module (9-pin RS-232) for all master controller locations.

For each master location and central control center, furnish a U.S. Robotics V.92 or approved equivalent auto-dial/auto-answer external modem to accomplish the interface to the Department-furnished microcomputers. Include all necessary hardware to ensure telecommunications.

ST-1

Project U-2707

Forsyth County

Project Special Provisions Structures

Table of Contents

	Page #
Placing Load on Structure Members (11-27-12)	----- ST-2
Steel Reinforced Elastomeric Bearings (11-27-12)	----- ST-2
Thermal Sprayed Coatings (Metallization) (9-30-11)	----- ST-2
Elastomeric Concrete (9-27-12)	----- ST-6
Foam Joint Seals (9-27-12)	----- ST-9
Expansion Joint Seals (9-30-11)	----- ST-12
Falsework and Formwork (4-5-12)	----- ST-16
Submittal of Working Drawings (6-19-15)	----- ST-22
Crane Safety (8-15-05)	----- ST-28
Grout for Structures (9-30-11)	----- ST-28
Asbestos Assessment for Bridge Demolition and Renovation Activities (12-30-15)	----- ST-30
Bridge Mounted Chain Link Fence (SPECIAL)	----- ST-32
NSRR Railroad Provisions	----- ST-33

For "Piles" and "Drilled Piers", see Geotechnical special provisions.

1/15/2016



DocuSigned by:

David Stutts

A4A2999A8BC64F2...

except for Railroad Provisions.

ST-2

PROJECT SPECIAL PROVISIONS **STRUCTURE**

PROJECT U-2707

FORSYTH COUNTY

PLACING LOAD ON STRUCTURE MEMBERS

(11-27-12)

The 2012 Standard Specifications shall be revised as follows:

In **Section 420-20 – Placing Load on Structure Members** replace the first sentence of the fifth paragraph with the following:

Do not place vehicles or construction equipment on a bridge deck until the deck concrete develops the minimum specified 28 day compressive strength and attains an age of at least 7 curing days.

STEEL REINFORCED ELASTOMERIC BEARINGS

(11-27-12)

The 2012 Standard Specifications shall be revised as follows:

In **Section 1079-1 – Preformed Bearing Pads** add the following after the second paragraph:

Internal holding pins are required for all shim plates when the contract plans indicate the structure contains the necessary corrosion protection for a corrosive site.

Repair laminated (reinforced) bearing pads utilizing external holding pins via vulcanization. Submit product data for repair material and a detailed application procedure to the Materials and Tests Unit for approval before use and annually thereafter.

THERMAL SPRAYED COATINGS (METALLIZATION)

(9-30-11)

1.0 DESCRIPTION

Apply a thermal sprayed coating (TSC) and sealer to metal surfaces as specified herein when called for on the plans or by other Special Provisions, or when otherwise approved by the Engineer in accordance with the SSPC-CS 23.00/AWS C2.23/NACE No. 12 Specification. Only Arc Sprayed application methods are used to apply TSC coatings, the Engineer must approve other methods of application.

2.0 QUALIFICATIONS

Only use NCDOT approved TSC Contractors meeting the following requirements:

1. The capability of blast cleaning steel surfaces to SSPC SP-5 and SP-10 Finishes.

ST-3

U-2707

Forsyth Co.

2. Employ Spray Operator(s) qualified in accordance with AWS C.16/C2.16M2002 and Quality Control Inspector(s) who have documented training in the applicable test procedures of ASTM D-3276 and SSPC-CS 23.00.

A summary of the contractor's related work experience and the documents verifying each Spray Operator's and Quality Control Inspector's qualifications are submitted to the Engineer before any work is performed.

3.0 MATERIALS

Provide wire in accordance with the metallizing equipment manufacturer's recommendations. Use the wire alloy specified on the plans which meets the requirements in Annex C of the SSPC-CS 23.00 Specification. Have the contractor provide a certified analysis (NCDOT Type 2 Certification) for each lot of wire material.

Apply an approved sealer to all metallized surfaces in accordance with Section 9 of SSPC-CS 23. The sealer must either meet SSPC Paint 27 or is an alternate approved by the Engineer.

4.0 SURFACE PREPARATION AND TSC APPLICATION

Grind flame cut edges to remove the carbonized surface prior to blasting. Bevel all flame cut edges in accordance with Article 442-10(D) regardless of included angle. Blast clean surfaces to be metallized with grit or mineral abrasive in accordance with Steel Structures Painting Council SSPC SP-5/10(as specified) to impart an angular surface profile of 2.5 - 4.0 mils. Surface preparation hold times are in accordance with Section 7.32 of SSPC-CS 23. If flash rusting occurs prior to metallizing, blast clean the metal surface again. Apply the thermal sprayed coating only when the surface temperature of the steel is at least 5°F above the dew point.

At the beginning of each work period or shift, conduct bend tests in accordance with Section 6.5 of SSPC-CS 23.00. Any disbonding or delamination of the coating that exposes the substrate requires corrective action, additional testing, and the Engineer's approval before resuming the metallizing process.

Apply TSC with the alloy to the thickness specified on the plans or as provided in the table below. All spot results (the average of 3 to 5 readings) must meet the minimum requirement. No additional tolerance (as allowed by SSPC PA-2) is permitted. (For Steel Beams: For pieces with less than 200 ft² measure 2 spots/surface per piece and for pieces greater than 200 ft² add 1 additional spots/surface for each 500 ft²).

ST-4

U-2707

Forsyth Co.

Application	Thickness	Alloy	Seal Coat
Pot Bearings	8 mil	85/15 Zinc (W-Zn-Al-2)	0.5 mil
Armored Joint Angles	8 mil	85/15 Zinc (W-Zn-Al-2)	0.5 mil
Modular Joints	8 mil	99.99% Zn (W-Zn-1)	0.5 mil
Expansion Joint Seals	8 mil	99.99% Zn (W-Zn-1)	0.5 mil
Optional Disc Bearings	8 mil	85/15 Zinc (W-Zn-Al-2)	0.5 mil

When noted on the plans or as specified in the above chart, apply the sealer to all metallized surfaces in accordance with the manufacturer's recommendations and these provisions. Apply the seal coat only when the air temperature is above 40°F and the surface temperature of the steel is at least 5°F above the dew point. If the sealer is not applied within eight hours after the final application of TSC, the applicator verifies acceptable TSC surfaces and obtains approval from the Engineer before applying the sealer.

5.0 INSPECTION FREQUENCY

The TSC Contractor must conduct the following tests at the specified frequency and the results documented in a format approved by the Engineer.

Test/Standard	Location	Frequency	Specification
Ambient Conditions	Site	Each Process	5°F above the dew point
Abrasive Properties	Site	Each Day	Size, angularity, cleanliness
Surface Cleanliness SSPC Vis 1	All Surfaces	Visual All Surfaces	SSPC-SP-10 Atmospheric Service SSPC-SP - 5 Immersion Service
Surface Profile ASTM D-4417 Method C	Random Surfaces	3 per 500 ft ²	2.5 - 4.0 mils
Bend Test SSPC-CS 23.00	Site	5 per shift	Pass Visual
Thickness SSPC PA-2R SSPC-CS 23.00	Each Surface	Use the method in PA-2 Appendix 3 for Girders and Appendix 4 for frames and miscellaneous steel. See Note 1.	Zn - 8 mils minimum Al - 8 mils minimum Zn Al - 8 mils minimum Areas with more than twice the minimum thickness are inspected for compliance to the adhesion and cut testing requirements of this specification.

ST-5

U-2707

Forsyth Co.

Test/Standard	Location	Frequency	Specification
Adhesion ASTM 4541	Random Surfaces Splice Areas	1 set of 3 per 500 ft ²	Zn > 500 psi Al > 1000 psi Zn Al > 750 psi
Cut Test - SSPC-CS 23.00	Random Surfaces	3 sets of 3 per 500 ft ²	No peeling or delamination
Job Reference Std. SSPC-CS 23.00	Site	1 per job	Meets all the above requirements

6.0 REPAIRS

All Repairs are to be performed in accordance with the procedures below, depending on whether the repair surface is hidden or exposed. As an exception to the following, field welded splices on joint angles and field welding bearing plates to girders may be repaired in accordance with the procedures for hidden surfaces.

For hidden surfaces (including but not limited to interior girders, interior faces of exterior girders, and below-grade sections of piles):

1. Welding of metallized surfaces may be performed only if specifically permitted by the Engineer. Remove metallizing at the location of field welds by blast cleaning (SSPC SP-6 finish), or hand (SSPC SP-2 finish) or power tool cleaning (SSPC SP-3 finish) just prior to welding. Clean sufficiently to prevent contamination of the weld. All repairs to welded connections are metallized in accordance with SSPC CS 23.00.
2. Minor areas less than or equal to 0.1 ft² exposing the substrate are metallized in accordance with SSPC CS 23.00 or painted in accordance with ASTM A780, "Repair of Damaged and Uncoated Areas of Hot Dip Galvanized Coatings."
3. Large areas greater than 0.1 ft² exposing the substrate are metallized in accordance with SSPC CS 23.00.
4. Damaged (burnished) areas not exposing the substrate with less than the specified coating thickness are metallized in accordance with SSPC CS 23.00 or painted in accordance with ASTM A780, "Repair of Damaged and Uncoated Areas of Hot Dip Galvanized Coatings."
5. Damaged (burnished) areas not exposing the substrate with more than the specified coating thickness are not repaired.
6. Defective coating is repaired by either method 2 or 3 depending on the area of the defect.

ST-6

U-2707

Forsyth Co.

For Exposed Surfaces (including but not limited to exterior faces of exterior girders and above-grade sections of piles):

1. Welding of metallized surfaces may be performed only if specifically permitted by the Engineer. Remove metallization at the location of field welds by blast cleaning (SSPC SP-6 finish), or hand (SSPC SP-2 finish) or power tool cleaning (SSPC SP-3 finish) just prior to welding. Clean sufficiently to prevent contamination of the weld. All repairs to welded connections are metallized in accordance with SSPC CS 23.00.
2. All areas exposing the substrate are metallized in accordance with SSPC CS 23.00
3. Defective coating is repaired by either method 2 or 3 depending on the area of the defect.

7.0 TWELVE MONTH OBSERVATION PERIOD

The contractor maintains responsibility for the coating system for a twelve (12) month observation period beginning upon the satisfactory completion of all the work required in the plans or as directed by the engineer. The contractor must guarantee the coating system under the payment and performance bond (refer to Article 109-10). To successfully complete the observation period, the coating system must meet the following requirements after twelve(12) months service:

- No visible rust, contamination or application defect is observed in any coated area.
- Painted surfaces have a uniform color and gloss.
- Surfaces have an adhesion of no less than 500 psi when tested in accordance with ASTM D-4541.

8.0 BASIS OF PAYMENT

The contract price bid for the bridge component to which the coating is applied will be full compensation for the thermal sprayed coating.

ELASTOMERIC CONCRETE

(9-27-12)

1.0 DESCRIPTION

Elastomeric concrete is a mixture of a two-part polymer consisting of polyurethane and/or epoxy and kiln-dried aggregate. Provide an elastomeric concrete and binder system that is preapproved. Use the concrete in the blocked out areas on both sides of the bridge deck joints as indicated on the plans.

2.0 MATERIALS

Provide materials that comply with the following minimum requirements at 14 days (or at the end of the specified curing time).

ST-7

U-2707

Forsyth Co.

ELASTOMERIC CONCRETE PROPERTIES	TEST METHOD	MINIMUM REQUIREMENT
Compressive Strength, psi	ASTM D695	2000
5% Deflection Resilience	ASTM D695	95
Splitting Tensile Strength, psi	ASTM D3967	625
Bond Strength to Concrete, psi	ASTM D882 (D882M)	450
Durometer Hardness	ASTM D2240	50

BINDER PROPERTIES (without aggregate)	TEST METHOD	MINIMUM REQUIREMENT
Tensile Strength, psi	ASTM D638	1000
Ultimate Elongation	ASTM D638	150%
Tear Resistance, lb/in	ASTM D624	200

In addition to the requirements above, the elastomeric concrete must be resistant to water, chemical, UV and ozone exposure and withstand temperature extremes. Elastomeric concrete systems requiring preheated aggregates are not allowed.

3.0 PREQUALIFICATION

Manufacturers of elastomeric concrete materials shall submit samples (including aggregate, primer and binder materials) and a Type 3 certification in accordance with Article 106-3 of the Standard Specifications for prequalification to:

North Carolina Department of Transportation
Materials and Tests Unit
1801 Blue Ridge Road
Raleigh, NC 27607

Prequalification will be determined for the system. Individual components will not be evaluated, nor will individual components of previously evaluated systems be deemed prequalified for use.

The submitted binder (a minimum volume of 1 gallon) and corresponding aggregate samples will be evaluated for compliance with the Materials requirements specified above. Systems satisfying all of the Materials requirements will be prequalified for a one year period. Before the end of this period new product samples shall be resubmitted for prequalification evaluation.

ST-8

U-2707

Forsyth Co.

If, at any time, any formulation or component modifications are made to a prequalified system that system will no longer be approved for use.

4.0 INSTALLATION

The elastomeric concrete shall not be placed until the reinforced concrete deck slab has cured for seven full days and reached a minimum strength of 3000 psi.

Provide a manufacturer's representative at the bridge site during the installation of the elastomeric concrete to ensure that all steps being performed comply with all manufacturer installation requirements including, but not limited to weather conditions (ambient temperature, relative humidity, precipitation, wind, etc), concrete deck surface preparation, binder and aggregate mixing, primer application, elastomeric concrete placement, curing conditions and minimum curing time before joint exposure to traffic. Do not place elastomeric concrete if the ambient air or surface temperature is below 45°F.

Prepare the concrete surface within 48 hours prior to placing the elastomeric concrete. Before placing the elastomeric concrete, all concrete surfaces shall be thoroughly cleaned and dry. Sandblast the concrete surface in the blockout and clear the surface of all loose debris. Do not place the elastomeric concrete until the surface preparation is completed and approved.

Prepare and apply a primer, as per manufacturer's recommendations, to all concrete faces to be in contact with elastomeric concrete, and to areas specified by the manufacturer.

Prepare, batch, and place the elastomeric concrete in accordance with the manufacturer's instructions. Place the elastomeric concrete in the areas specified on the plans while the primer is still tacky and within 2 hours after applying the primer. Trowel the elastomeric concrete to a smooth finish.

The joint opening in the elastomeric concrete shall match the formed opening in the concrete deck prior to sawing the joint.

5.0 FIELD SAMPLING

Provide additional production material to allow freshly mixed elastomeric concrete to be sampled for acceptance. A minimum of six 2 inch cube molds and three 3x6 inch cylinders will be taken by the Department for each day's production. Compression, splitting tensile, and durometer hardness testing will be performed by the Department to determine acceptance. Materials failing to meet the requirements listed above are subject to removal and replacement at no cost to the Department.

6.0 BASIS OF PAYMENT

No separate payment will be made for elastomeric concrete. The lump sum contract price bid for "Foam Joint Seals" will be full compensation for furnishing and placing the Elastomeric Concrete.

ST-9

U-2707

Forsyth Co.

FOAM JOINT SEALS

(9-27-12)

1.0 SEALS

Use preformed seals compatible with concrete and resistant to abrasion, oxidation, oils, gasoline, salt and other materials that are spilled on or applied to the surface. Use a resilient, UV stable, preformed, impermeable, flexible, expansion joint seal. The joint seal shall consist of low-density, closed cell, cross-linked polyethylene non-extrudable, foam. The joint seal shall contain no EVA (Ethylene Vinyl Acetate). Cell generation shall be achieved by being physically blown using nitrogen. No chemical blowing agents shall be used in the cell generation process.

Use seals manufactured with grooves $1/8'' \pm$ wide by $1/8'' \pm$ deep and spaced between $1/4''$ and $1/2''$ apart along the bond surface running the length of the joint. Use seals with a depth that meets the manufacturer's recommendation, but is not less than 70% of the uncompressed width. Provide a seal designed so that, when compressed, the center portion of the top does not extend upward above the original height of the seal by more than $1/4''$. Provide a seal that has a working range of 30% tension and 60% compression and meets the requirements given below.

TEST	TEST METHOD	REQUIREMENT
Tensile strength	ASTM D3575-08, Suffix T	110 – 130 psi
Compression Set	ASTM D1056 Suffix B, 2 hr recovery	10% - 16%
Water Absorption	ASTM D3575	< 0.03 lb/ft ²
Elongation at Break	ASTM D3575	180% - 210%
Tear Strength	ASTM D624 (D3575-08, Suffix G)	14 – 20 pli
Density	ASTM D3575-08, Suffix W, Method A	1.8 – 2.2 lb/ft ³
Toxicity	ISO-10993.5	Pass (not cytotoxic)

Have the top of the joint seal clearly shop marked. Inspect the joint seals upon receipt to ensure that the marks are clearly visible before installation.

2.0 BONDING ADHESIVE

Use a two component, 100% solid, modified epoxy adhesive supplied by the joint seal manufacturer that meets the requirements given below.

ST-10

U-2707

Forsyth Co.

TEST	TEST METHOD	REQUIREMENT
Tensile strength	ASTM D638	3000 psi (min.)
Compressive strength	ASTM D695	7000 psi (min.)
Hardness	Shore D Scale	75-85 psi
Water Absorption	ASTM D570	0.25% by weight max.
Elongation to Break	ASTM D638	5% (max.)
Bond Strength	ASTM C882	2000 psi (min.)

Use an adhesive that is workable to 40°F. When installing in ambient air or surface temperatures below 40°F or for application on moist, difficult to dry concrete surfaces, use an adhesive specified by the manufacturer of the joint seal.

3.0 SAWING THE JOINT

The joint opening shall be initially formed to the width shown on the plans including the blockout for the elastomeric concrete.

The elastomeric concrete shall have sufficient time to cure such that no damage can occur to the elastomeric concrete prior to sawing to the final width and depth as specified in the plans.

When sawing the joint to receive the foam seal, always use a rigid guide to control the saw in the desired direction. To control the saw and to produce a straight line as indicated on the plans, anchor and positively connect a template or a track to the bridge deck. Do not saw the joint by visual means such as a chalk line. Fill the holes used for holding the template or track to the deck with an approved, flowable non-shrink, non-metallic grout.

Saw cut to the desired width and depth in one or two passes of the saw by placing and spacing two metal blades on the saw shaft to the desired width for the joint opening.

The desired depth is the depth of the seal plus 1/4" above the top of the seal plus approximately 1" below the bottom of the seal. An irregular bottom of sawed joint is permitted as indicated on the plans. Grind exposed corners on saw cut edges to a 1/4" chamfer.

Saw cut a straight joint, centered over the formed opening and to the desired width specified in the plans. Prevent any chipping or damage to the sawed edges of the joint.

Remove any staining or deposited material resulting from sawing with a wet blade to the satisfaction of the Engineer.

4.0 PREPARATION OF SAWED JOINT FOR SEAL INSTALLATION

The elastomeric concrete shall cure a minimum of 24 hours prior to seal installation.

After sawing the joint, the Engineer will thoroughly inspect the sawed joint opening for spalls, popouts, cracks, etc. All necessary repairs will be made by the Contractor prior to blast cleaning and installing the seal.

Clean the joints by sandblasting with clean dry sand immediately before placing the bonding agent. Sandblast the joint opening to provide a firm, clean joint surface free of curing compound, loose material and any foreign matter. Sandblast the joint opening without causing pitting or uneven surfaces. The aggregate in the elastomeric concrete may be exposed after sandblasting.

After blasting, either brush the surface with clean brushes made of hair, bristle or fiber, blow the surface with compressed air, or vacuum the surface until all traces of blast products and abrasives are removed from the surface, pockets, and corners.

If nozzle blasting is used to clean the joint opening, use compressed air that does not contain detrimental amounts of water or oil.

Examine the blast cleaned surface and remove any traces of oil, grease or smudge deposited in the cleaning operations.

Bond the seal to the blast cleaned surface on the same day the surface is blast cleaned.

5.0 SEAL INSTALLATION

Install the joint seal according to the manufacturer's procedures and recommendations and as recommended below. Do not install the joint seal if the ambient air or surface temperature is below 45°F. Have a manufacturer's certified trained factory representative present during the installation of the first seal of the project.

Before installing the joint seal, check the uninstalled seal length to insure the seal is the same length as the deck opening. When the joint seal requires splicing, use the heat welding method by placing the joint material ends against a teflon heating iron of 425-475°F for 7 - 10 seconds, then pressing the ends together tightly. Do not test the welding until the material has completely cooled.

Begin installation by protecting the top edges of the concrete deck adjacent to the vertical walls of the joint as a means to minimize clean up. After opening both cans of the bonding agent, stir each can using separate stirring rods for each component to prevent premature curing of the bonding agent. Pour the two components, at the specified mixing ratio, into a clean mixing bucket. Mix the components with a low speed drill (400 rpm max.) until a uniform gray color is achieved without visible marbling. Apply bonding agent to both sides of the elastomeric concrete as well as both sides of the joint seal, making certain to

completely fill the grooves with epoxy. With gloved hands, compress the joint seal and with the help of a blunt probe, push the seal into the joint opening until the seal is recessed approximately 1/4" below the surface. When pushing down on the joint seal, apply pressure only in a downward direction. Do not push the joint seal into the joint opening at an angle that would stretch the material. Seals that are stretched during installation shall be removed and rejected. Once work on placing a seal begins, do not stop until it is completed. Clean the excess epoxy from the top of the joint seal immediately with a trowel. Do not use solvents or any cleaners to remove the excess epoxy from the top of the seal. Remove the protective cover at the joint edges and check for any excess epoxy on the surface. Remove excess epoxy with a trowel, the use of solvents or any cleaners will not be allowed.

The installed system shall be watertight and will be monitored until final inspection and approval. Do not place pavement markings on top of foam joint seals.

6.0 BASIS OF PAYMENT

Payment for all foam joint seals will be at the lump sum contract price bid for "Foam Joint Seals". Prices and payment will be full compensation for furnishing all material, including elastomeric concrete, labor, tools and equipment necessary for installing these units in place and accepted.

EXPANSION JOINT SEALS

(9-30-11)

1.0 GENERAL

The work covered by this Special Provision consists of furnishing and installing the expansion joint seals as shown on the contract drawings. All materials, labor, equipment and incidentals necessary for the proper installation of the expansion joint seals are included.

2.0 MATERIAL

Provide expansion joint seals capable of accommodating a total movement measured parallel to the centerline of the roadway as shown on plans.

Provide an elastomeric component for each expansion joint seal that is a continuous unit for the entire length of the joint. Do not field splice the elastomeric component. Only vulcanized shop splicing of the elastomeric component is permitted. The minimum length of an elastomeric component before shop splicing is 20 feet. However, one piece shorter than 20 feet is permitted. Provide an elastomeric component that is clearly shop marked to indicate the top side and joint location of the elastomeric component. On skewed bridges, or under unsymmetrical conditions, clearly mark the left side of the elastomeric component. Left is defined as being on the left when facing in the direction of increasing station. Inspect the seals upon receipt to ensure that the marks are clearly visible upon installation.

ST-13

U-2707

Forsyth Co.

Make sure the convolution of the gland does not project above the top of the hold-down plates when the joint opening is in the most compressed condition. Use either elastic polychloroprene (neoprene) or ethyl propylene diene monomer (EPDM) for the elastomer that meets the following minimum properties:

	ASTM TEST METHOD	REQUIREMENTS
Hardness, Durometer - Shore A	D2240	60 ± 5, Neoprene (upward corrugated shape - fabric reinforced) 75 ± 5, EPDM and Neoprene (upward non-corrugated shape) 80 ± 5, EPDM (upward corrugated shape-fabric reinforced)
Tensile Strength	D412	2000 psi (min.)
Elongation at Break	D412	250% (min.)
Width of Gland in Relaxed Condition	N/A	10" ± 0.25"

Thickness of Upturned portion of gland	N/A	0.25" non-corrugated shape, -0.032" to +0.032"
Thickness of Upturned portion of gland	N/A	0.1875" corrugated shape, -0.032" to +0.032"
Thickness of Flat portion of gland	N/A	0.1563", -0.032" to +0.032"

For fabric reinforced glands, submit one unreinforced sample per lot number, up to 500 feet of Expansion Joint Seal, to the Engineer for testing.

Only field splice hold-down plates at crown points, at abrupt changes in the deck slab cross slope, and on lane lines. Splicing within travel lanes is not permitted and splicing on edge lines is not required. Field splice hold-down plates between the edge line and gutter upturn and where necessary for proper installation and alignment is permitted. Show all splice locations on the working drawings for approval. For the location of lane markings at the expansion joint seal, see the Structure plans. At the splice locations, locate the hold-down bolts 3 inches from the end of the hold-down plate. At splice locations where changes in deck slab cross slope occur, cut the ends of hold-down plates parallel to the bridge centerline for skews less than 80° and greater than 100°.

Do not use welded shop splices in hold-down plates.

3.0 SHOP DRAWINGS

Submit nine sets of working drawings to the Engineer for review, comments and acceptance. Show complete details drawn to scale and include:

- The proposed template details including the makeup of the template
- The proposed method of holding the base angle assembly in place while concrete is cast around it
- The proposed procedure to correct for the effects of beam movement and rotation when setting width of joint opening
- The proposed chronology of installation including the sequence and direction of the concrete casting
- The details of cross connectors between base angles, such as steel bars with slots bolted to angles, to maintain evenness between the adjacent base angles while accommodating movement that occurs when concrete is cast. Indicate when bolts are loosened to allow movement.
- The proposed method for removing the hold-down plate
- A section detail through the joint showing horizontal offset dimensions of the base angles from the centerline joint. This detail is required when the vertical face of the joint opening is not perpendicular to the roadway surface (e.g. when the roadway grade is significant).

Have someone other than the one who prepares the drawing check all detailed drawings and include the signatures of both the drafter and checker on each sheet of the drawings. The Engineer returns unchecked drawings to the Contractor. Provide all completed drawings well in advance of the scheduled installation time for the expansion joint seal.

4.0 INSTALLATION

Provide supports for the base angle assembly at a maximum spacing of 9 feet. Place supports near field splices of base angles to ensure that field splices are straight and even. Provide base angles with ½" diameter weep holes at 12 inch centers to allow bleeding of trapped air and/or water. Do not obstruct the weep holes with falsework. Make the bottom of the trough parallel to grade and the sides parallel to the sides of the expansion joint seal.

For damaged areas, depressions, spalls, cracks, or irregularities of curbs or decks adjacent to the expansion joint, submit a proposed method of repair and repair material specifications for approval.

If the Engineer deems any aspects of the expansion joint seals unacceptable, make necessary corrections.

5.0 INSPECTION

When concrete is cast, use a non-aluminum, 10 foot, true to line straight edge to check and grade the top of the slab on each side of the joint to ensure smooth transition between spans.

Watertight Integrity Test

- Upon completion of an expansion joint seal, perform a water test on the top surface to detect any leakage. Cover the roadway section of the joint from curb to curb, or barrier rail to barrier rail, with water, either ponded or flowing, not less than 1 inch above the roadway surface at all points. Block sidewalk sections and secure an unnozzled water hose delivering approximately 1 gallon of water per minute to the inside face of the bridge railing, trained in a downward position about 6 inches above the sidewalks, such that there is continuous flow of water across the sidewalk and down the curb face of the joint.
- Maintain the ponding or flowing of water on the roadway and continuous flow across sidewalks and curbs for a period of 5 hours. At the conclusion of the test, the underside of the joint is closely examined for leakage. The expansion joint seal is considered watertight if no obvious wetness is visible on the Engineer's finger after touching a number of underdeck areas. Damp concrete that does not impart wetness to the finger is not a sign of leakage.
- If the joint system leaks, locate the place(s) of leakage and take any repair measures necessary to stop the leakage at no additional cost to the Department. Use repair measures recommended by the manufacturer and approved by the Engineer prior to beginning corrective work.
- If measures to eliminate leakage are taken, perform a subsequent water integrity test subject to the same conditions as the original test. Subsequent tests carry the same responsibility as the original test and are performed at no extra cost to the Department.

6.0 BASIS OF PAYMENT

Basis of payment for all expansion joint seals will be at the lump sum contract price for "Expansion Joint Seals" which price and payment will be full compensation for furnishing all material, including any steel accessory plates for sidewalks, medians and rails, labor, tools, and incidentals necessary for installing the expansion joint seal in place and including all materials, labor, tools and incidentals for performing the original watertight integrity test.

FALSEWORK AND FORMWORK

(4-5-12)

1.0 DESCRIPTION

Use this Special Provision as a guide to develop temporary works submittals required by the Standard Specifications or other provisions; no additional submittals are required herein. Such temporary works include, but are not limited to, falsework and formwork.

Falsework is any temporary construction used to support the permanent structure until it becomes self-supporting. Formwork is the temporary structure or mold used to retain plastic or fluid concrete in its designated shape until it hardens. Access scaffolding is a temporary structure that functions as a work platform that supports construction personnel, materials, and tools, but is not intended to support the structure. Scaffolding systems that are used to temporarily support permanent structures (as opposed to functioning as work platforms) are considered to be falsework under the definitions given. Shoring is a component of falsework such as horizontal, vertical, or inclined support members. Where the term “temporary works” is used, it includes all of the temporary facilities used in bridge construction that do not become part of the permanent structure.

Design and construct safe and adequate temporary works that will support all loads imposed and provide the necessary rigidity to achieve the lines and grades shown on the plans in the final structure.

2.0 MATERIALS

Select materials suitable for temporary works; however, select materials that also ensure the safety and quality required by the design assumptions. The Engineer has authority to reject material on the basis of its condition, inappropriate use, safety, or nonconformance with the plans. Clearly identify allowable loads or stresses for all materials or manufactured devices on the plans. Revise the plan and notify the Engineer if any change to materials or material strengths is required.

3.0 DESIGN REQUIREMENTS

A. Working Drawings

Provide working drawings for items as specified in the contract, or as required by the Engineer, with design calculations and supporting data in sufficient detail to permit a structural and safety review of the proposed design of the temporary work.

On the drawings, show all information necessary to allow the design of any component to be checked independently as determined by the Engineer.

When concrete placement is involved, include data such as the drawings of proposed sequence, rate of placement, direction of placement, and location of all construction joints. Submit the number of copies as called for by the contract.

ST-17

U-2707

Forsyth Co.

When required, have the drawings and calculations prepared under the guidance of, and sealed by, a North Carolina Registered Professional Engineer who is knowledgeable in temporary works design.

If requested by the Engineer, submit with the working drawings manufacturer's catalog data listing the weight of all construction equipment that will be supported on the temporary work. Show anticipated total settlements and/or deflections of falsework and forms on the working drawings. Include falsework footing settlements, joint take-up, and deflection of beams or girders.

As an option for the Contractor, overhang falsework hangers may be uniformly spaced, at a maximum of 36 inches, provided the following conditions are met:

Member Type (PCG)	Member Depth, (inches)	Max. Overhang Width, (inches)	Max. Slab Edge Thickness, (inches)	Max. Screenshot Wheel Weight, (lbs.)	Bracket Min. Vertical Leg Extension, (inches)
II	36	39	14	2000	26
III	45	42	14	2000	35
IV	54	45	14	2000	44
MBT	63	51	12	2000	50
MBT	72	55	12	1700	48

Overhang width is measured from the centerline of the girder to the edge of the deck slab.

For Type II, III & IV prestressed concrete girders (PCG), 45-degree cast-in-place half hangers and rods must have a minimum safe working load of 6,000 lbs.

For MBT prestressed concrete girders, 45-degree angle holes for falsework hanger rods shall be cast through the girder top flange and located, measuring along the top of the member, 1'-2 1/2" from the edge of the top flange. Hanger hardware and rods must have a minimum safe working load of 6,000 lbs.

The overhang bracket provided for the diagonal leg shall have a minimum safe working load of 3,750 lbs. The vertical leg of the bracket shall extend to the point that the heel bears on the girder bottom flange, no closer than 4 inches from the bottom of the member. However, for 72-inch members, the heel of the bracket shall bear on the web, near the bottom flange transition.

Provide adequate overhang falsework and determine the appropriate adjustments for deck geometry, equipment, casting procedures and casting conditions.

If the optional overhang falsework spacing is used, indicate this on the falsework submittal and advise the girder producer of the proposed details. Failure to notify the

ST-18

U-2707

Forsyth Co.

Engineer of hanger type and hanger spacing on prestressed concrete girder casting drawings may delay the approval of those drawings.

Falsework hangers that support concentrated loads and are installed at the edge of thin top flange concrete girders (such as bulb tee girders) shall be spaced so as not to exceed 75% of the manufacturer's stated safe working load. Use of dual leg hangers (such as Meadow Burke HF-42 and HF-43) are not allowed on concrete girders with thin top flanges. Design the falsework and forms supporting deck slabs and overhangs on girder bridges so that there will be no differential settlement between the girders and the deck forms during placement of deck concrete.

When staged construction of the bridge deck is required, detail falsework and forms for screed and fluid concrete loads to be independent of any previous deck pour components when the mid-span girder deflection due to deck weight is greater than $\frac{3}{4}$ ".

Note on the working drawings any anchorages, connectors, inserts, steel sleeves or other such devices used as part of the falsework or formwork that remains in the permanent structure. If the plan notes indicate that the structure contains the necessary corrosion protection required for a Corrosive Site, epoxy coat, galvanize or metalize these devices. Electroplating will not be allowed. Any coating required by the Engineer will be considered incidental to the various pay items requiring temporary works.

Design falsework and formwork requiring submittals in accordance with the 1995 AASHTO *Guide Design Specifications for Bridge Temporary Works* except as noted herein.

1. Wind Loads

Table 2.2 of Article 2.2.5.1 is modified to include wind velocities up to 110 mph. In addition, Table 2.2A is included to provide the maximum wind speeds by county in North Carolina.

Table 2.2 - Wind Pressure Values

Height Zone feet above ground	Pressure, lb/ft ² for Indicated Wind Velocity, mph				
	70	80	90	100	110
0 to 30	15	20	25	30	35
30 to 50	20	25	30	35	40
50 to 100	25	30	35	40	45
over 100	30	35	40	45	50

ST-19

U-2707

Forsyth Co.

2. Time of Removal

The following requirements replace those of Article 3.4.8.2.

Do not remove forms until the concrete has attained strengths required in Article 420-16 of the Standard Specifications and these Special Provisions.

Do not remove forms until the concrete has sufficient strength to prevent damage to the surface.

Table 2.2A - Steady State Maximum Wind Speeds by Counties in North Carolina

COUNTY	25 YR (mph)	COUNTY	25 YR (mph)	COUNTY	25 YR (mph)
Alamance	70	Franklin	70	Pamlico	100
Alexander	70	Gaston	70	Pasquotank	100
Alleghany	70	Gates	90	Pender	100
Anson	70	Graham	80	Perquimans	100
Ashe	70	Granville	70	Person	70
Avery	70	Greene	80	Pitt	90
Beaufort	100	Guilford	70	Polk	80
Bertie	90	Halifax	80	Randolph	70
Bladen	90	Harnett	70	Richmond	70
Brunswick	100	Haywood	80	Robeson	80
Buncombe	80	Henderson	80	Rockingham	70
Burke	70	Hertford	90	Rowan	70
Cabarrus	70	Hoke	70	Rutherford	70
Caldwell	70	Hyde	110	Sampson	90
Camden	100	Iredell	70	Scotland	70
Carteret	110	Jackson	80	Stanley	70
Caswell	70	Johnston	80	Stokes	70
Catawba	70	Jones	100	Surry	70
Cherokee	80	Lee	70	Swain	80
Chatham	70	Lenoir	90	Transylvania	80
Chowan	90	Lincoln	70	Tyrell	100
Clay	80	Macon	80	Union	70
Cleveland	70	Madison	80	Vance	70
Columbus	90	Martin	90	Wake	70
Craven	100	McDowell	70	Warren	70
Cumberland	80	Mecklenburg	70	Washington	100
Currituck	100	Mitchell	70	Watauga	70

Table 2.2A - Steady State Maximum Wind Speeds by Counties in North Carolina

COUNTY	25 YR (mph)	COUNTY	25 YR (mph)	COUNTY	25 YR (mph)
Dare	110	Montgomery	70	Wayne	80
Davidson	70	Moore	70	Wilkes	70
Davie	70	Nash	80	Wilson	80
Duplin	90	New Hanover	100	Yadkin	70
Durham	70	Northampton	80	Yancey	70
Edgecombe	80	Onslow	100		
Forsyth	70	Orange	70		

B. Review and Approval

The Engineer is responsible for the review and approval of temporary works' drawings.

Submit the working drawings sufficiently in advance of proposed use to allow for their review, revision (if needed), and approval without delay to the work.

The time period for review of the working drawings does not begin until complete drawings and design calculations, when required, are received by the Engineer.

Do not start construction of any temporary work for which working drawings are required until the drawings have been approved. Such approval does not relieve the Contractor of the responsibility for the accuracy and adequacy of the working drawings.

4.0 CONSTRUCTION REQUIREMENTS

All requirements of Section 420 of the Standard Specifications apply.

Construct temporary works in conformance with the approved working drawings. Ensure that the quality of materials and workmanship employed is consistent with that assumed in the design of the temporary works. Do not weld falsework members to any portion of the permanent structure unless approved. Show any welding to the permanent structure on the approved construction drawings.

Provide tell-tales attached to the forms and extending to the ground, or other means, for accurate measurement of falsework settlement. Make sure that the anticipated compressive settlement and/or deflection of falsework does not exceed 1 inch. For cast-in-place concrete structures, make sure that the calculated deflection of falsework flexural members does not exceed 1/240 of their span regardless of whether or not the deflection is compensated by camber strips.

A. Maintenance and Inspection

Inspect and maintain the temporary work in an acceptable condition throughout the period of its use. Certify that the manufactured devices have been maintained in a condition to allow them to safely carry their rated loads. Clearly mark each piece so that its capacity can be readily determined at the job site.

Perform an in-depth inspection of an applicable portion(s) of the temporary works, in the presence of the Engineer, not more than 24 hours prior to the beginning of each concrete placement. Inspect other temporary works at least once a month to ensure that they are functioning properly. Have a North Carolina Registered Professional Engineer inspect the cofferdams, shoring, sheathing, support of excavation structures, and support systems for load tests prior to loading.

B. Foundations

Determine the safe bearing capacity of the foundation material on which the supports for temporary works rest. If required by the Engineer, conduct load tests to verify proposed bearing capacity values that are marginal or in other high-risk situations.

The use of the foundation support values shown on the contract plans of the permanent structure is permitted if the foundations are on the same level and on the same soil as those of the permanent structure.

Allow for adequate site drainage or soil protection to prevent soil saturation and washout of the soil supporting the temporary works supports.

If piles are used, the estimation of capacities and later confirmation during construction using standard procedures based on the driving characteristics of the pile is permitted. If preferred, use load tests to confirm the estimated capacities; or, if required by the Engineer conduct load tests to verify bearing capacity values that are marginal or in other high risk situations.

The Engineer reviews and approves the proposed pile and soil bearing capacities.

5.0 REMOVAL

Unless otherwise permitted, remove and keep all temporary works upon completion of the work. Do not disturb or otherwise damage the finished work.

Remove temporary works in conformance with the contract documents. Remove them in such a manner as to permit the structure to uniformly and gradually take the stresses due to its own weight.

6.0 METHOD OF MEASUREMENT

Unless otherwise specified, temporary works will not be directly measured.

7.0 BASIS OF PAYMENT

Payment at the contract unit prices for the various pay items requiring temporary works will be full compensation for the above falsework and formwork.

SUBMITTAL OF WORKING DRAWINGS

(6-19-15)

1.0 GENERAL

Submit working drawings in accordance with Article 105-2 of the *Standard Specifications* and this provision. For this provision, “submittals” refers to only those listed in this provision. The list of submittals contained herein does not represent a list of required submittals for the project. Submittals are only necessary for those items as required by the contract. Make submittals that are not specifically noted in this provision directly to the Engineer. Either the Structures Management Unit or the Geotechnical Engineering Unit or both units will jointly review submittals.

If a submittal contains variations from plan details or specifications or significantly affects project cost, field construction or operations, discuss the submittal with and submit all copies to the Engineer. State the reason for the proposed variation in the submittal. To minimize review time, make sure all submittals are complete when initially submitted. Provide a contact name and information with each submittal. Direct any questions regarding submittal requirements to the Engineer, Structures Management Unit contacts or the Geotechnical Engineering Unit contacts noted below.

In order to facilitate in-plant inspection by NCDOT and approval of working drawings, provide the name, address and telephone number of the facility where fabrication will actually be done if different than shown on the title block of the submitted working drawings. This includes, but is not limited to, precast concrete items, prestressed concrete items and fabricated steel or aluminum items.

2.0 ADDRESSES AND CONTACTS

For submittals to the Structures Management Unit, use the following addresses:

Via US mail:

Mr. T. K. Koch, P. E.
State Structures Engineer
North Carolina Department
of Transportation
Structures Management Unit
1581 Mail Service Center
Raleigh, NC 27699-1581

Attention: Mr. P. D. Lambert, P. E.

Via other delivery service:

Mr. T. K. Koch, P. E.
State Structures Engineer
North Carolina Department
of Transportation
Structures Management Unit
1000 Birch Ridge Drive
Raleigh, NC 27610

Attention: Mr. P. D. Lambert, P. E.

ST-23

U-2707

Forsyth Co.

Submittals may also be made via email.

Send submittals to:

plambert@ncdot.gov (Paul Lambert)

Send an additional e-copy of the submittal to the following address:

jgaither@ncdot.gov (James Gaither)

mrorie@ncdot.gov (Madonna Rorie)

For submittals to the Geotechnical Engineering Unit, use the following addresses:

For projects in Divisions 1-7, use the following Eastern Regional Office address:

Via US mail:

Mr. K. J. Kim, Ph. D., P. E.
Eastern Regional Geotechnical
Manager
North Carolina Department
of Transportation
Geotechnical Engineering Unit
Eastern Regional Office
1570 Mail Service Center
Raleigh, NC 27699-1570

Via other delivery service:

Mr. K. J. Kim, Ph. D., P. E.
Eastern Regional Geotechnical
Manager
North Carolina Department
of Transportation
Geotechnical Engineering Unit
Eastern Regional Office
3301 Jones Sausage Road, Suite 100
Garner, NC 27529

For projects in Divisions 8-14, use the following Western Regional Office address:

Via US mail:

Mr. Eric Williams, P. E.
Western Regional Geotechnical
Manager
North Carolina Department
of Transportation
Geotechnical Engineering Unit
Western Regional Office
5253 Z Max Boulevard
Harrisburg, NC 28075

Via other delivery service:

Mr. Eric Williams, P. E.
Western Region Geotechnical
Manager
North Carolina Department
of Transportation
Geotechnical Engineering Unit
Western Regional Office
5253 Z Max Boulevard
Harrisburg, NC 28075

The status of the review of structure-related submittals sent to the Structures Management Unit can be viewed from the Unit's web site, via the "Drawing Submittal Status" link.

Direct any questions concerning submittal review status, review comments or drawing markups to the following contacts:

Primary Structures Contact: Paul Lambert (919) 707 – 6407
(919) 250 – 4082 facsimile
plambert@ncdot.gov

ST-24

U-2707

Forsyth Co.

Secondary Structures Contacts: James Gaither (919) 707 – 6409
Madonna Rorie (919) 707 – 6508

Eastern Regional Geotechnical Contact (Divisions 1-7):
K. J. Kim (919) 662 – 4710
(919) 662 – 3095 facsimile
kkim@ncdot.gov

Western Regional Geotechnical Contact (Divisions 8-14):
Eric Williams (704) 455 – 8902
(704) 455 – 8912 facsimile
ewilliams3@ncdot.gov

3.0 SUBMITTAL COPIES

Furnish one complete copy of each submittal, including all attachments, to the Engineer. At the same time, submit the number of hard copies shown below of the same complete submittal directly to the Structures Management Unit and/or the Geotechnical Engineering Unit.

The first table below covers “Structure Submittals”. The Engineer will receive review comments and drawing markups for these submittals from the Structures Management Unit. The second table in this section covers “Geotechnical Submittals”. The Engineer will receive review comments and drawing markups for these submittals from the Geotechnical Engineering Unit.

Unless otherwise required, submit one set of supporting calculations to either the Structures Management Unit or the Geotechnical Engineering Unit unless both units require submittal copies in which case submit a set of supporting calculations to each unit. Provide additional copies of any submittal as directed.

STRUCTURE SUBMITTALS

Submittal	Copies Required by Structures Management Unit	Copies Required by Geotechnical Engineering Unit	Contract Reference Requiring Submittal ¹
Arch Culvert Falsework	5	0	Plan Note, SN Sheet & “Falsework and Formwork”
Box Culvert Falsework ⁷	5	0	Plan Note, SN Sheet & “Falsework and Formwork”
Cofferdams	6	2	Article 410-4

ST-25

U-2707

Forsyth Co.

Foam Joint Seals ⁶	9	0	“Foam Joint Seals”
Expansion Joint Seals (hold down plate type with base angle)	9	0	“Expansion Joint Seals”
Expansion Joint Seals (modular)	2, then 9	0	“Modular Expansion Joint Seals”
Expansion Joint Seals (strip seals)	9	0	“Strip Seals”
Falsework & Forms ² (substructure)	8	0	Article 420-3 & “Falsework and Formwork”
Falsework & Forms (superstructure)	8	0	Article 420-3 & “Falsework and Formwork”
Girder Erection over Railroad	5	0	Railroad Provisions
Maintenance and Protection of Traffic Beneath Proposed Structure	8	0	“Maintenance and Protection of Traffic Beneath Proposed Structure at Station ____”
Metal Bridge Railing	8	0	Plan Note
Metal Stay-in-Place Forms	8	0	Article 420-3
Metalwork for Elastomeric Bearings ^{4,5}	7	0	Article 1072-8
Miscellaneous Metalwork ^{4,5}	7	0	Article 1072-8
Disc Bearings ⁴	8	0	“Disc Bearings”
Overhead and Digital Message Signs (DMS) (metalwork and foundations)	13	0	Applicable Provisions
Placement of Equipment on Structures (cranes, etc.)	7	0	Article 420-20
Precast Concrete Box Culverts	2, then 1 reproducible	0	“Optional Precast Reinforced Concrete Box Culvert at Station ____”
Prestressed Concrete Cored Slab (detensioning sequences) ³	6	0	Article 1078-11

ST-26

U-2707

Forsyth Co.

Prestressed Concrete Deck Panels	6 and 1 reproducible	0	Article 420-3
Prestressed Concrete Girder (strand elongation and detensioning sequences)	6	0	Articles 1078-8 and 1078- 11
Removal of Existing Structure over Railroad	5	0	Railroad Provisions
Revised Bridge Deck Plans (adaptation to prestressed deck panels)	2, then 1 reproducible	0	Article 420-3
Revised Bridge Deck Plans (adaptation to modular expansion joint seals)	2, then 1 reproducible	0	“Modular Expansion Joint Seals”
Sound Barrier Wall (precast items)	10	0	Article 1077-2 & “Sound Barrier Wall”
Sound Barrier Wall Steel Fabrication Plans ⁵	7	0	Article 1072-8 & “Sound Barrier Wall”
Structural Steel ⁴	2, then 7	0	Article 1072-8
Temporary Detour Structures	10	2	Article 400-3 & “Construction, Maintenance and Removal of Temporary Structure at Station _____”
TFE Expansion Bearings ⁴	8	0	Article 1072-8

FOOTNOTES

1. References are provided to help locate the part of the contract where the submittals are required. References in quotes refer to the provision by that name. Articles refer to the *Standard Specifications*.
2. Submittals for these items are necessary only when required by a note on plans.
3. Submittals for these items may not be required. A list of pre-approved sequences is available from the producer or the Materials & Tests Unit.
4. The fabricator may submit these items directly to the Structures Management Unit.
5. The two sets of preliminary submittals required by Article 1072-8 of the *Standard Specifications* are not required for these items.

ST-27

U-2707

Forsyth Co.

6. Submittals for Fabrication Drawings are not required. Submittals for Catalogue Cuts of Proposed Material are required. See Section 5.A of the referenced provision.
7. Submittals are necessary only when the top slab thickness is 18” or greater.

GEOTECHNICAL SUBMITTALS

Submittal	Copies Required by Geotechnical Engineering Unit	Copies Required by Structures Management Unit	Contract Reference Requiring Submittal ¹
Drilled Pier Construction Plans ²	1	0	Subarticle 411-3(A)
Crosshole Sonic Logging (CSL) Reports ²	1	0	Subarticle 411-5(A)(2)
Pile Driving Equipment Data Forms ^{2,3}	1	0	Subarticle 450-3(D)(2)
Pile Driving Analyzer (PDA) Reports ²	1	0	Subarticle 450-3(F)(3)
Retaining Walls ⁴	8 drawings, 2 calculations	2 drawings	Applicable Provisions
Temporary Shoring ⁴	5 drawings, 2 calculations	2 drawings	“Temporary Shoring” & “Temporary Soil Nail Walls”

FOOTNOTES

1. References are provided to help locate the part of the contract where the submittals are required. References in quotes refer to the provision by that name. Subarticles refer to the *Standard Specifications*.
2. Submit one hard copy of submittal to the Engineer. Submit a second copy of submittal electronically (PDF via email) or by facsimile, US mail or other delivery service to the appropriate Geotechnical Engineering Unit regional office. Electronic submission is preferred.
3. The Pile Driving Equipment Data Form is available from:
https://connect.ncdot.gov/resources/Geological/Pages/Geotech_Forms_Details.aspx
See second page of form for submittal instructions.
4. Electronic copy of submittal is required. See referenced provision.

CRANE SAFETY

(8-15-05)

Comply with the manufacturer specifications and limitations applicable to the operation of any and all cranes and derricks. Prime contractors, sub-contractors, and fully operated rental companies shall comply with the current Occupational Safety and Health Administration regulations (OSHA).

Submit all items listed below to the Engineer prior to beginning crane operations involving critical lifts. A critical lift is defined as any lift that exceeds 75 percent of the manufacturer's crane chart capacity for the radius at which the load will be lifted or requires the use of more than one crane. Changes in personnel or equipment must be reported to the Engineer and all applicable items listed below must be updated and submitted prior to continuing with crane operations.

CRANE SAFETY SUBMITTAL LIST

- A. **Competent Person:** Provide the name and qualifications of the "Competent Person" responsible for crane safety and lifting operations. The named competent person will have the responsibility and authority to stop any work activity due to safety concerns.
- B. **Riggers:** Provide the qualifications and experience of the persons responsible for rigging operations. Qualifications and experience should include, but not be limited to, weight calculations, center of gravity determinations, selection and inspection of sling and rigging equipment, and safe rigging practices.
- C. **Crane Inspections:** Inspection records for all cranes shall be current and readily accessible for review upon request.
- D. **Certifications:** **By July 1, 2006**, crane operators performing critical lifts shall be certified by NC CCO (National Commission for the Certification of Crane Operators), or satisfactorily complete the Carolinas AGC's Professional Crane Operator's Proficiency Program. Other approved nationally accredited programs will be considered upon request. All crane operators shall also have a current CDL medical card. Submit a list of anticipated critical lifts and corresponding crane operator(s). Include current certification for the type of crane operated (small hydraulic, large hydraulic, small lattice, large lattice) and medical evaluations for each operator.

GROUT FOR STRUCTURES

(9-30-11)

1.0 DESCRIPTION

This special provision addresses grout for use in pile blockouts, grout pockets, shear keys, dowel holes and recesses for structures. This provision does not apply to grout placed in post-tensioning ducts for bridge beams, girders, or decks. Mix and place grout in accordance with the manufacturer's recommendations, the applicable sections of the Standard Specifications and this provision.

2.0 MATERIAL REQUIREMENTS

Use a Department approved pre-packaged, non-shrink, non-metallic grout. Contact the Materials and Tests Unit for a list of approved pre-packaged grouts and consult the manufacturer to determine if the pre-packaged grout selected is suitable for the required application.

When using an approved pre-packaged grout, a grout mix design submittal is not required.

The grout shall be free of soluble chlorides and contain less than one percent soluble sulfate. Supply water in compliance with Article 1024-4 of the Standard Specifications.

Aggregate may be added to the mix only where recommended or permitted by the manufacturer and Engineer. The quantity and gradation of the aggregate shall be in accordance with the manufacturer's recommendations.

Admixtures, if approved by the Department, shall be used in accordance with the manufacturer's recommendations. The manufacture date shall be clearly stamped on each container. Admixtures with an expired shelf life shall not be used.

The Engineer reserves the right to reject material based on unsatisfactory performance.

Initial setting time shall not be less than 10 minutes when tested in accordance with ASTM C266.

Test the expansion and shrinkage of the grout in accordance with ASTM C1090. The grout shall expand no more than 0.2% and shall exhibit no shrinkage. Furnish a Type 4 material certification showing results of tests conducted to determine the properties listed in the Standard Specifications and to assure the material is non-shrink.

Unless required elsewhere in the contract the compressive strength at 3 days shall be at least 5000 psi. Compressive strength in the laboratory shall be determined in accordance with ASTM C109 except the test mix shall contain only water and the dry manufactured material. Compressive strength in the field will be determined by molding and testing 4" x 8" cylinders in accordance with AASHTO T22. Construction loading and traffic loading shall not be allowed until the 3 day compressive strength is achieved.

When tested in accordance with ASTM C666, Procedure A, the durability factor of the grout shall not be less than 80.

3.0 SAMPLING AND PLACEMENT

Place and maintain components in final position until grout placement is complete and accepted. Concrete surfaces to receive grout shall be free of defective concrete, laitance, oil, grease and other foreign matter. Saturate concrete surfaces with clean water and remove excess water prior to placing grout.

ST-30

U-2707

Forsyth Co.

Do not place grout if the grout temperature is less than 50°F or more than 90°F or if the air temperature measured at the location of the grouting operation in the shade away from artificial heat is below 45°F.

Provide grout at a rate that permits proper handling, placing and finishing in accordance with the manufacturer's recommendations unless directed otherwise by the Engineer. Use grout free of any lumps and undispersed cement. Agitate grout continuously before placement.

Control grout delivery so the interval between placing batches in the same component does not exceed 20 minutes.

The Engineer will determine the locations to sample grout and the number and type of samples collected for field and laboratory testing. The compressive strength of the grout will be considered the average compressive strength test results of 3 cube or 2 cylinder specimens at 28 days.

4.0 BASIS OF PAYMENT

No separate payment will be made for "Grout for Structures". The cost of the material, equipment, labor, placement, and any incidentals necessary to complete the work shall be considered incidental to the structure item requiring grout.

ASBESTOS ASSESSMENT FOR BRIDGE DEMOLITION AND RENOVATION ACTIVITIES

(12-30-15)

1.0 INSPECTION FOR ASBESTOS CONTAINING MATERIAL

Prior to conducting bridge demolition or renovation activities, the Contractor shall thoroughly inspect the bridge or affected components for the presence of asbestos containing material (ACM) using a firm prequalified by NCDOT to perform asbestos surveys. The inspection must be performed by a N.C. accredited asbestos inspector with experience inspecting bridges or other industrial structures. The N.C. accredited asbestos inspector must conduct a thorough inspection, identifying all asbestos-containing material as required by the Environmental Protection Agency National Emission Standards for Hazardous Air Pollutants (NESHAP) Code of Federal Regulations (CFR) 40 CFR, Part 61, Subpart M.

The Contractor shall submit an inspection report to the Engineer, which at a minimum must include information required in 40 CFR 763.85 (a)(4) vi)(A)-(E), as well as a project location map, photos of existing structure, the date of inspection and the name, N.C. accreditation number, and signature of the N.C. accredited asbestos inspector who performed the inspection and completed the report. The cover sheet of the report shall include project identification information. Place the following notes on the cover sheet of the report and check the appropriate box:

___ ACM was found
___ ACM was not found

2.0 REMOVAL AND DISPOSAL OF ASBESTOS CONTAINING MATERIAL

If ACM is found, notify the Engineer. Compensation for removal and disposal of ACM is considered extra work in accordance with Article 104-7 of the Standard Specifications.

An Asbestos Removal Permit must be obtained from the Health Hazards Control Unit (HHCU) of the N.C. Department of Health & Human Services, Division of Public Health, if more than 35 cubic feet, 160 square feet, or 260 linear feet of regulated ACM (RACM) is to be removed from a structure and this work must be completed by a contractor prequalified by NCDOT to perform asbestos abatement. RACM is defined in 40 CFR, Part 61, Subpart M. Note: 40 CFR 763.85 (a)(4) vi)(D) defines ACM as surfacing, TSI and Miscellaneous which does not meet the NESHAP RACM.

3.0 DEMOLITION NOTIFICATION

Even if no ACM is found (or if quantities are less than those required for a permit), a Demolition Notification (DHHS-3768) must be submitted to the HHCU. Notifications and Asbestos Permit applications require an original signature and must be submitted to the HHCU 10 working days prior to beginning demolition activities. The 10 working day period starts based on the post-marked date or date of hand delivery. Demolition that does not begin as originally notified requires submission of a separate revision form HHCU 3768-R to HHCU. Reference the North Carolina Administrative Code, Chapter 10A, Subchapter 41C, Article .0605 for directives on revision submissions.

Contact Information

Health Hazards Control Unit (HHCU)
N.C. Department of Health and Human Services
1912 Mail Service Center
Raleigh, NC 27699-1912
Telephone: (919) 707-5950
Fax: (919) 870-4808

4.0 SPECIAL CONSIDERATIONS

Buncombe, Forsyth, and Mecklenburg counties also have asbestos permitting and NESHAP requirements must be followed. For projects involving permitted RACM removals, both the applicable county and the state (HHCU) must be notified.

For demolitions with no RACM, only the local environmental agencies must be notified. Contact information is as follows:

U-2707

Forsyth Co.

Buncombe County
WNC Regional Air Pollution Control Agency
49 Mt. Carmel Road
Asheville, NC 28806
(828) 250-6777

Forsyth County
Environmental Affairs Department
537 N. Spruce Street
Winston-Salem, NC 27101
(336) 703-2440

Mecklenburg County
Land Use and Environmental Services Agency
Mecklenburg Air Quality
700 N. Tryon Street
Charlotte, NC 28202
(704) 336-5430

5.0 ADDITIONAL INFORMATION

Additional information may be found on N.C. asbestos rules, regulations, procedures and N.C. accredited inspectors, as well as associated forms for demolition notifications and asbestos permit applications at the N.C. Asbestos Hazard Management Program website:

www.epi.state.nc.us/epi/asbestos/ahmp.html

6.0 BASIS OF PAYMENT

Payment for the work required in this provision will be at the lump sum contract unit price for "Asbestos Assessment". Such payment will be full compensation for all asbestos inspections, reports, permitting and notifications.

BRIDGE MOUNTED CHAIN LINK FENCE

(SPECIAL)

Construct the chain link fence in accordance with the applicable sections of the Standard Specifications, the details shown on the plans and this special provision.

The quantity of chain link fence will be the actual number of linear feet of fence, measured in place from end post to end post, which has been completed and accepted. All posts used for the chain link fence are included in the price of the fence and will not be paid for separately. There will be no measurement made for installing adhesive anchors in concrete parapets as such work is considered incidental.

ST-33

U-2707

Forsyth Co.

Work includes but is not limited to furnishing and installing fence fabric, tie wires, stretcher bars, stretcher bar bands, tie rods, turnbuckles, brace rails, posts, post caps, brackets, adhesive anchors, fittings and any other materials necessary to complete the work as described in the plans and this special provision.

Payment will be made under:

72" Chain Link Fence _____ Linear Foot

SPECIAL PROVISIONS FOR PROTECTION OF RAILWAY INTEREST

Under the terms of these provisions, the North Carolina Department of Transportation shall hereinafter be called "Department", and the Norfolk Southern Railway Company shall hereinafter be called "Railroad".

1. AUTHORITY OF RAILROAD ENGINEER AND DEPARTMENT ENGINEER:

The authorized representative of the Railroad, hereinafter referred to as Railroad Engineer, shall have final authority in all matters affecting the safe maintenance of Railroad traffic including the adequacy of the foundations and structures supporting the Railroad tracks.

The authorized representative of the North Carolina Department of Transportation, hereinafter referred to as the Department Engineer, shall have authority over all other matters as prescribed herein including Project Specifications, Special Provisions, and the plans.

2. NOTICE OF STARTING WORK:

A. The Contractor shall not commence any work on Railroad right of way until he has complied with the following conditions:

(1) Give the Railroad written notice, with copy to the Department Engineer who is designated to be in charge of the work, at least ten (10) days in advance of the date he proposes to begin work on Railroad right of way to:

Office of Chief Engineer - Bridges & Structures
Norfolk Southern Corporation
1200 Peachtree Street NE
Internal Box 142
Atlanta, Georgia 30309

(2) Obtain written approval from the Railroad of Railroad Protective Liability Insurance coverage as required by section 14 herein. The Railroad does not accept notation of

ST-34

U-2707

Forsyth Co.

Railroad protective insurance on a certificate of liability insurance form or Binders as Railroad must have the full original countersigned policy. The policy will be reviewed for compliance prior to written approval. Due to the number of projects system-wide, it typically takes a minimum of 30-45 days for Railroad to review.

(3) Obtain Railroad's Flagging Services as required by section 7 herein.

(4) Obtain written authorization from the Railroad to begin work on Railroad's right of way, such authorization to include an outline of specific conditions with which he must comply.

(5) Furnish a schedule for all work within the Railroad right of way as required by section 7B1 herein.

B. The Railroad's written authorization to proceed with the work will include the names, addresses, and telephone numbers of the Railroad's representatives who are to be notified as hereinafter required. Where more than one representative is designated, the area of responsibility of each representative will be specified.

3. INTERFERENCE WITH RAILROAD OPERATIONS:

A. The Contractor shall so arrange and conduct his work that there will be no interference with Railroad operations, including train, signal, telephone and telegraphic services, or damage to the property of the Railroad or to poles, wires, and other facilities of tenants on the right of way of the Railroad. Whenever work is liable to affect the operations or safety of trains, the method of doing such work shall first be submitted to the Railroad Engineer for approval, but such approval shall not relieve the Contractor from liability. Any work to be performed by the Contractor which requires flagging service or inspection service (watchman) shall be deferred by the Contractor until the flagging protection or inspection service required by the Railroad is available at the job site.

B. Whenever work within Railroad's right of way is of such a nature that impediment to Railroad operations such as use of runaround tracks or necessity for reduced speed is unavoidable, the Contractor shall schedule and conduct his operations so that such impediment is reduced to the absolute minimum.

C. Should conditions arising from, or in connection with the work, require that immediate and unusual provisions be made to protect operations and property of the Railroad, the Contractor shall make such provisions. If in the judgment of the Railroad Engineer, or in his absence, the Railroad's Division Engineer, such provision is insufficient, either may require or provide such provisions as he deems necessary. In any event, such unusual provisions shall be at the Contractor's expense and without cost to the Railroad or the Department.

ST-35

U-2707

Forsyth Co.

4. TRACK CLEARANCES:

A. The minimum track clearances to be maintained by the Contractor during construction are as follows:

(1) Horizontal clearance measured from centerline of track to falsework:

13'-0" on tangent track

14'-0" on curved track

(2) Vertical clearance from top of rail to falsework: 22'-0"

B. However, before undertaking any work within Railroad's right of way, or before placing any obstruction over any track, the Contractor shall:

(1) Notify the Railroad Engineer at least 72 hours in advance of the work.

(2) Receive assurance from the Railroad Engineer that arrangements have been made for flagging service as may be necessary.

(3) Receive permission from the Railroad Engineer to proceed with the work.

(4) Ascertain that the Department Engineer has received copies of notice to the Railroad and of the Railroad's response thereto.

5. CONSTRUCTION PROCEDURES:

A. General:

Construction work and operations by the Contractor on Railroad's property shall be:

(1) Subject to the inspection and approval of the Railroad.

(2) In accord with the Railroad's written outline of specific conditions.

(3) In accord with the Railroad's general rules, regulations and requirements including those relating to safety, fall protection and personal protective equipment.

(4) In accord with these Special Provisions.

B. Excavation:

The subgrade of an operated track shall be maintained with edge of berm at least 10'-0" from centerline of track and not more than 24 inches below top of rail. The Contractor

will not be required to make existing section meet this specification if substandard, in which case existing section will be maintained.

Additionally, the Railroad Engineer may require the Contractor to install orange construction safety fencing for protection of the work area.

C. Excavation for Structures:

The Contractor will be required to take special precaution and care in connection with excavating and shoring pits, and in driving piles or sheeting, for footings adjacent to tracks to provide adequate lateral support for the tracks and the loads which they carry, without disturbance of track alignment and surface, and to avoid obstructing track clearances with working equipment, tools or other material. All plans and calculations for shoring shall be prepared and signed by a North Carolina Registered Professional Engineer. The Professional Engineer will be responsible for the accuracy for all controlling dimensions as well as the selection of soil design values which will accurately reflect the actual field conditions. The procedure for doing such work, including need of and plans for shoring, shall first be reviewed by the Department Engineer then reviewed and approved by the Railroad Engineer, but such approval shall not relieve the Contractor from liability.

Additionally, a walkway with handrail protection may be required as noted in section 11 herein.

D. Demolition, Erection, Hoisting:

- (1) Railroad tracks and other Railroad property must be protected from damage during the procedure.
- (2) The Contractor is required to submit a plan showing the locations of cranes, horizontally and vertically, operating radii, with delivery or disposal locations shown. The location of all tracks and other railroad facilities as well as wire lines, poles, adjacent structures, etc. must also be shown.
- (3) Crane rating sheets showing cranes to be adequate for 150% of the actual weight of the pick. A complete set of crane charts, including crane, counterweight, and boom nomenclature is to be submitted.
- (4) Plans and computations showing the weight of the picks must be submitted. Calculations shall be made from plans of the existing and/or proposed structure showing complete and sufficient details with supporting data for the demolition or erection of the structure. If plans do not exist, lifting weights must be calculated from filed measurements. The field measurements are to be made under the supervision of the North Carolina Registered Professional Engineer submitting the procedure and calculations.

ST-37

U-2707

Forsyth Co.

- (5) A data sheet must be submitted listing the types, size and arrangements of all rigging and connection equipment.
- (6) A complete written procedure is to be submitted, including the order of lifts, time required for each lift, and any repositioning or rehitching of the crane or cranes.
- (7) All erection or demolition plans, procedures, data sheets, etc. submitted must be prepared, signed and sealed by a North Carolina Registered Professional Engineer.
- (8) The Railroad Engineer or his designated representative must be present at the site during the entire demolition and erection procedure period.
- (9) All procedures, plans and calculations shall first be reviewed by the Department Engineer and then approved by the Railroad Engineer, but such approval does not relieve the Contractor from liability.

E. Blasting:

- (1) The Contractor shall obtain advance approval of the Railroad Engineer and Department Engineer for use of explosives on or adjacent to Railroad property. The request for permission to use explosives shall include a detailed blasting plan. If permission for use of explosives is granted, the Contractor will be required to comply with the following:
 - (a) Blasting shall be done with light charges under the direct supervision of a responsible officer or employee of the Contractor and a licensed blaster.
 - (b) Electric detonating fuses shall not be used because of the possibility of premature explosions resulting from operation of two-way train radios.
 - (c) No blasting shall be done without the presence of the Railroad Engineer or his authorized representative. At least 72 hours advance notice to the person designated in the Railroad's notice of authorization to proceed (see section 2B above) will be required to arrange for the presence of an authorized Railroad representative and such flagging as the Railroad may require.
 - (d) Have at the job site adequate equipment, labor and materials and allow sufficient time to clean up debris resulting from the blasting without delay to trains, as well as correcting at his expense any track misalignment or other damage to Railroad property resulting from the blasting as directed by the Railroad Engineer. If his actions result in delay of trains, the Contractor shall bear the entire cost thereof.

(2) The Railroad Engineer will:

(a) Determine the approximate location of trains and advise the Contractor the approximate amount of time available for the blasting operation and clean-up.

(b) Have the authority to order discontinuance of blasting if, in his opinion, blasting is too hazardous or is not in accord with these special provisions.

F. Maintenance of Railroad Facilities:

(1) The Contractor will be required to maintain all ditches and drainage structures free of silt or other obstructions which may result from his operations and provide and maintain any erosion control measures as required. The Contractor will promptly repair eroded areas within Railroad's right of way and repair any other damage to the property of the Railroad or its tenants.

(2) All such maintenance and repair of damages due to the Contractor's operations shall be done at the Contractor's expense.

G. Storage of Materials and Equipment:

Materials and equipment shall not be stored where they will interfere with Railroad operations, nor on the right of way of the Railroad without first having obtained permission from the Railroad Engineer, and such permission will be with the understanding that the Railroad will not be liable for damage to such material and equipment from any cause and that the Railroad Engineer may move or require the Contractor to move, at the Contractor's expense, such material and equipment.

All grading or construction machinery that is left parked near the track unattended by a watchman shall be effectively immobilized so that it cannot be moved by unauthorized persons. The Contractor shall protect, defend, indemnify and save Railroad, and any associated, controlled or affiliated corporation, harmless from and against all loss, costs, expenses, claim or liability for loss of or damage to property or the loss of life or personal injury, arising out of or incident to the Contractor's failure to immobilize grading or construction machinery.

H. Cleanup:

Upon completion of the work, the Contractor shall remove from within the limits of the Railroad's right of way, all machinery, equipment, surplus materials, falsework, rubbish or temporary buildings of the Contractor, and leave said right of way in a neat condition satisfactory to the Chief Engineer of the Railroad or his authorized representative.

ST-39

U-2707

Forsyth Co.

6. DAMAGES:

- A. The Contractor shall assume all liability for any and all damages to his work, employees, servants, equipment and materials caused by Railroad traffic.
- B. Any cost incurred by the Railroad for repairing damages to its property or to property of its tenants, caused by or resulting from the operations of the Contractor, shall be paid directly to the Railroad by the Contractor.

7. FLAGGING SERVICES:

A. Requirements:

Flagging services will not be provided until the Contractor's insurance has been reviewed and approved by the Railroad.

Under the terms of the agreement between the Department and Railroad, the Railroad has sole authority to determine the need for flagging required to protect its operations. In general, the requirements of such services will be whenever the Contractor's men or equipment are, or are likely to be, working on the Railroad's right of way, or across, over, adjacent to or under a track, or when such work has disturbed or is likely to disturb a Railroad structure, Railroad roadbed, or surface and alignment of any track to such extent that the movement of trains must be controlled by flagging.

Normally, the Railroad will assign one flagman to a project; but in some cases, more than one may be necessary, such as yard limits where three (3) flagmen may be required. However, if the Contractor works within distances that violate instructions given by the Railroad Engineer or performs work that has not been scheduled with the Railroad Engineer, a flagman or flagmen may be required full time until the project has been completed. Should such violations or unscheduled, unauthorized work by the Contractor result in full time flagging being required by the Railroad, the additional cost of such flagging above normal flagging cost shall be deducted from the final payment to the Contractor as provided in Article 109-9 of the Standard Specifications. Neither Department nor Railroad will be liable for damages resulting from unscheduled or unauthorized work.

B. Scheduling and Notification:

(1) The Contractor's work requiring railroad flagging should be scheduled to limit the presence of a flagman at the site to a maximum of 50 hours per week. The Contractor shall receive Railroad approval of work schedules requiring a flagman presence in excess of 40 hours per week.

(2) No later than the time that approval is initially requested to begin work on Railroad right of way, the Contractor shall furnish to the Department and Railroad a schedule for all

work required to complete the portion of the project within Railroad right of way and arrange for a job site meeting between the Contractor, Department, and Railroad. Flagman or flagmen may not be provided until the job site meeting has been conducted and the Contractor's work scheduled.

(3) The Contractor will be required to give the Railroad Engineer at least 10 working days of advance written notice of intent to begin work within Railroad's right of way in accordance with this special provision. Once begun, when such work is then suspended at any time, or for any reason, the Contractor will be required to give the Railroad Engineer at least 3 working days of advance notice before resuming work on Railroad's right of way. Such notices shall include sufficient details of the proposed work to enable the Railroad Engineer to determine if flagging will be required. If such notice is in writing, the Contractor shall furnish the Department Engineer a copy; if notice is given verbally, it shall be confirmed in writing with a copy to the Department Engineer.

(4) If flagging is required, no work shall be undertaken until the flagman, or flagmen, is present at the job site. It may take up to 30 days to obtain flagging initially from the Railroad. When flagging begins, the flagman is usually assigned by the Railroad to work at the project site on a continual basis until no longer needed and cannot be called for on a spot basis. If flagging becomes unnecessary and is suspended, it may take up to 30 days to again obtain from the Railroad. Due to labor agreements, it is necessary to give 5 working days notice before flagging service may be discontinued and responsibility for payment stopped.

(5) If, after the flagman is assigned to the project site, emergencies arise which require the flagman's presence elsewhere, the Contractor shall delay work on Railroad right of way until such time as the flagman is again available. Any additional costs resulting from such delay shall be borne by the Contractor and not the Department or Railroad.

C. Payment:

(1) The Department will be responsible for paying the Railroad directly for any and all costs of flagging which may be required to accomplish the construction. The Contractor shall reimburse the Railroad for any costs of the flagging which is required for work for the benefit of the Contractor.

(2) The estimated cost of flagging service is the current rate per day based on a 10-hour work day. This cost includes the base pay for each flagman, overhead, and a per diem charge for travel expenses, meals and lodging. The charge by the Railroad will be the actual cost based on the rate of pay for the Railroad's employees who are available for flagging service at the time the service is required.

(3) Work by a flagman in excess of 8 hours per day or 40 hours per week, but not more than 12 hours a day will result in overtime pay at 1½ times the appropriate rate. Work by a flagman in excess of 12 hours per day will result in overtime pay at 2 times the

appropriate rate. If work is performed on a holiday, the flagging rate is 2½ times the normal rate.

- (4) Railroad work involved in preparing and handling bills will also be charged to the Department. Charges to the Department by the Railroad shall be in accordance with applicable provisions of the Federal-Aid Policy Guide, Title 23 Subchapter B, Part 140I and Subchapter G, Part 646B issued by the Federal Highway Administration on December 9, 1991, including all current amendments. Flagging costs are subject to change. The above estimates of flagging costs are provided for information only and are not binding in any way.

D. Verification:

- (1) Railroad's flagman will electronically enter flagging time via Railroad's electronic billing system. Any complaints concerning flagman or flagmen must be resolved in a timely manner. If need for flagman or flagmen is questioned, please contact Railroad's System Engineer of Public Improvements at (404) 529-1641. All verbal complaints must be confirmed in writing by the Contractor within 5 working days with copy to the Department Engineer. Address all written correspondence to:

Office of Chief Engineer-Bridges & Structures
Attn: System Engineer of Public Improvements
Norfolk Southern Corporation
1200 Peachtree St. NE
Internal Box 142
Atlanta, GA 30309

- (2) The Railroad flagman assigned to the project will be responsible for notifying the Department Engineer upon arrival at the job site on the first day (or as soon thereafter as possible) that flagging services begin and on the last day that he performs such services for each separate period that services are provided. The Department Engineer will document such notification and general flagging times for verification purposes in the project records. When requested, the Department Engineer will also sign the flagman's diary showing daily time spent and activity at the project site. Also if requested, the flagman will cooperate with the Department by submitting daily timesheets or signing the Department Engineer's diary showing daily time spent at the project site.

8. HAUL ACROSS RAILROADS:

- A. Where the plans show or imply that materials of any nature must be hauled across a Railroad, unless the plans clearly show that the Department has included arrangements for such haul in its agreement with the Railroad, the Contractor will be required to make all necessary arrangements with the Railroad regarding means of transporting such materials across the Railroad. The Contractor will be required to bear all costs incidental, including

ST-42

U-2707

Forsyth Co.

flagging, to such crossings whether services are performed by his own forces or by Railroad personnel.

- B. No crossing may be established for use of the Contractor for transporting materials or equipment across the tracks of the Railroad unless specific authority for its installation, maintenance, necessary watching and flagging thereof and removal, all at the expense of the Contractor, is first obtained from the Railroad Engineer. The approval process for a temporary private crossing agreement executed between the Contractor and Railroad normally takes 90 days.

9. WORK FOR THE BENEFIT OF THE CONTRACTOR:

- A. All temporary or permanent changes in wire lines or other facilities which are considered necessary to the project are shown on the plans and included in the force account agreement between the Department and the Railroad; or will be covered by appropriate revisions to same which will be initiated and approved by the Department and/or Railroad.
- B. Should the Contractor desire any changes in addition to the above, then he shall make separate arrangements with the Railroad for same to be accomplished at the Contractor's expense.

10. COOPERATION AND DELAYS:

- A. It shall be the Contractor's responsibility to arrange a schedule with the Railroad for accomplishing stage construction involving work by the Railroad or tenants of the Railroad. In arranging his schedule he shall ascertain, from the Railroad, the lead time required for assembling crews and materials and shall make due allowance therefore. The Contractor shall cooperate with others in the construction of the project to the end that all work may be accomplished to the best advantage.
- B. No charge or claims of the Contractor against either the Department or Railroad will be allowed for hindrance or delay on account of railroad traffic, any work done by the Railroad or other delay incident to or necessary for safe maintenance of railroad traffic or for any delays due to compliance with these special provisions.
- C. The Contractor's attention is called to the fact that neither the Department nor Railroad assumes any responsibility for any work performed by others in connection with the construction of the project, and the Contractor shall have no claim whatsoever against the Department, or Railroad for any inconvenience, delay, or additional cost incurred by him on account of such operations by others.

11. TRAINMAN'S WALKWAYS:

Along the outer side of each exterior track of multiple operated tracks, and on each side of single operated track, an unobstructed continuous space suitable for trainman's use in

walking along trains, extending to a line not less than 10' from centerline of track, shall be maintained. Any temporary impediments to walkways and track drainage encroachments or obstructions allowed during work hours while Railroad's protective service is provided shall be removed before the close of each work day. If there is any excavation near the walkway, a handrail, with 10'-0" minimum clearance from centerline of track shall be placed.

12. GUIDELINES FOR PERSONNEL ON RAILROAD'S RIGHT OF WAY:

- A. All persons shall wear hard hats. Appropriate eye and hearing protection must be used. Working in shorts is prohibited. Shirts must cover shoulders, back and abdomen. Working in tennis or jogging shoes, sandals, boots with high heels, cowboy and other slip-on type boots is prohibited. Hard-sole, lace-up footwear, zippered boots or boots cinched up with straps which fit snugly about the ankle are adequate. Wearing Safety boots is strongly recommended. In the vicinity of at-grade crossings, it is strongly recommended to wear reflective vests.
- B. No one is allowed within 25' of the centerline of track without specific authorization from the flagman.
- C. All persons working near track while train is passing are to lookout for dragging bands, chains and protruding or shifted cargo.
- D. No one is allowed to cross tracks without specific authorization from the flagman.
- E. All welders and cutting torches working within 25' of track must stop when train is passing.
- F. No steel tape or chain will be allowed to cross or touch rails without permission.

13. GUIDELINES FOR EQUIPMENT ON RAILROAD'S RIGHT OF WAY:

- A. No crane or boom equipment will be allowed to set up to work or park within boom distance plus 15 ft. of centerline of track without specific permission from Railroad Engineer and flagman.
- B. No crane or boom equipment will be allowed to foul track or lift a load over the track without flag protection and track time.
- C. All employees will stay with their machines when crane or boom equipment is pointed toward track.
- D. All cranes and boom equipment under load will stop work while train is passing (including pile driving).

ST-44

U-2707

Forsyth Co.

- E. Swinging loads must be secured to prevent movement while train is passing.
- F. No loads will be suspended above a moving train.
- G. No equipment will be allowed within 25' of centerline of track without specific authorization of the flagman.
- H. Trucks, tractors or any equipment will not touch ballast line without specific permission from railroad official and flagman.
- I. No equipment or load movement within 25' or above a standing train or railroad equipment without specific authorization of the flagman.
- J. All operating equipment within 25' of track must halt operations when a train is passing. All other operating equipment may be halted by the flagman if the flagman views the operation to be dangerous to the passing train.
- K. All equipment, loads and cables are prohibited from touching rails.
- L. While clearing and grubbing, no vegetation will be removed from Railroad embankment with heavy equipment without specific permission from the Railroad Engineer and flagman.
- M. No equipment or materials will be parked or stored on Railroad's property unless specific authorization is granted from the Railroad Engineer.
- N. All unattended equipment that is left parked on Railroad's property shall be effectively immobilized so that it cannot be moved by unauthorized persons.
- O. All cranes and boom equipment will be turned away from track after each work day or whenever unattended by an operator.

14. INSURANCE:

- A. In addition to any other forms of insurance or bonds required under the terms of the contract and specifications, the Prime Contractor will be required to provide coverage conforming to the requirements of the Federal-Aid Policy Guide outlined under Title 23 Subchapter G, Part 646A for all work to be performed on Railroad's right of way by carrying insurance of the following kinds and amounts:
 - (1) **Commercial General Liability Insurance** having a combined single limit of not less than \$2,000,000 per occurrence for all loss, damage, cost and expense, including attorneys' fees, arising out of bodily injury liability and property damage liability during the policy period. Said policy shall include explosion, collapse, and underground hazard (XCU) coverage, shall be endorsed to name Railroad specified in section 14A2(c) below both as

U-2707

Forsyth Co.

the certificate holder and as an additional insured, and shall include a severability of interests provision.

- (2) **Railroad Protective Liability Insurance** having a combined single limit of not less than \$2,000,000 each occurrence and \$6,000,000 in the aggregate applying separately to each annual period. If the project involves track over which passenger trains operate, the insurance limits required are not less than a combined single limit of \$5,000,000 each occurrence and \$10,000,000 in the aggregate applying separately to each annual period. Said policy shall provide coverage for all loss, damage or expense arising from bodily injury and property damage liability, and physical damage to property attributed to acts or omissions at the job site.

The standards for the Railroad Protective Liability Insurance are as follows:

- (a) The insurer must be rated A- or better by A.M. Best Company, Inc.
- (b) The policy must be written using one of the following combinations of Insurance Services Office (“ISO”) Railroad Protective Liability Insurance Form Numbers:
- (1) CG 00 35 01 96 and CG 28 31 10 93; or
 - (2) CG 00 35 07 98 and CG 28 31 07 98; or
 - (3) CG 00 35 10 01; or
 - (4) CG 00 35 12 04
- (c) The named insured shall read:
- Norfolk Southern Railway Company
Three Commercial Place
Norfolk, Virginia 23510-2191
Attn: Risk Management
- (d) The description of operations must appear on the Declarations, must match the project description in this agreement, and must include the appropriate Department project and contract identification numbers.

The Description and Designation shall read:

Description and Designation: Removal of existing Bridge No. 109 and construction of a new overhead bridge on SR 2999 (Hampton Road) over the tracks of Norfolk Southern Railway Company in Forsyth County, North Carolina identified as State TIP U-2707 and Federal Project STP-3000(5).

- (e) The job location must appear on the Declarations and must include the city, state, and appropriate highway name/number.

ST-46

U-2707

Forsyth Co.

NOTE: Do not include any references to milepost on the insurance policy.

- (f) The name and address of the prime contractor must appear on the Declarations.
 - (g) The name and address of the Department must be identified on the Declarations as the “Involved Governmental Authority or Other Contracting Party.”
 - (h) Other endorsements/forms that will be accepted are:
 - (1) Broad Form Nuclear Exclusion – Form IL 00 21
 - (2) 30-day Advance Notice of Non-renewal or cancellation
 - (3) 60-day written notice to the Department prior to cancellation or change
 - (4) Quick Reference or Index Form CL/IL 240
 - (i) Endorsements/forms that are **NOT** acceptable are:
 - (1) Any Pollution Exclusion Endorsement except CG 28 31
 - (2) Any Punitive or Exemplary Damages Exclusion
 - (3) Known injury or Damage Exclusion form CG 00 59
 - (4) Any Common Policy Conditions form
 - (5) Any other endorsement/form not specifically authorized in section 14A2(h) above.
- B. If any part of the work is sublet, similar insurance, and evidence thereof as specified in section 14A1 above, shall be provided by or on behalf of the subcontractor to cover its operations on Railroad’s right of way. As an alternative, the Prime Contractor may provide insurance for the subcontractor by means of separate and individual policies.
- C. Prior to entry on Railroad’s right of way, the original and one duplicate copy of the Railroad Protective Liability Insurance Policy shall be submitted by the Prime Contractor to the Department at the address below for its review and transmittal to the Railroad. In addition, certificates of insurance evidencing the Prime Contractor’s and any subcontractors’ Commercial General Liability Insurance shall be issued to the Department and Railroad at the addresses below, and one certified copy of the Prime Contractor and any Subcontractors policy is to be forwarded to the Department for its review and transmittal to the Railroad. All policies and certificates of insurance shall state that the insurance coverage will not be suspended, voided, canceled, or reduced in coverage or limits without (30) days advance written notice to the Department and Railroad. The Railroad will not permit any work on its right of way until it has reviewed and approved the evidence of insurance required herein.

ST-47

U-2707

Forsyth Co.

DEPARTMENT:

NCDOT Rail Division
Engineering & Safety Branch
C/O State Railroad Agent
1556 Mail Service Center
Raleigh, NC 27699-1556

RAILROAD:

Risk Management
Norfolk Southern Railway Company
Three Commercial Place
Norfolk, Virginia 23510-2191

- D. The insurance required herein shall in no way serve to limit the liability of Department or its Contractors under the terms of this agreement.
- E. The insurance amounts specified are minimum amounts and the Contractor may carry insurance in larger amounts if he so desires. As to "aggregate limits", if the insurer establishes loss reserves equal to or in excess of the aggregate limit specified in any of the required insurance policies, the Contractor shall immediately notify the Department and shall cease all operations until the aggregate limit is reinstated. If the insurer establishes loss reserves equal to or in excess of one/half of the aggregate limit, the Contractor shall arrange to restore the aggregate limit to at least the minimum amount stated in these requirements. Any insurance policies and certificates taken out and furnished due to these requirements shall be approved by the Department and Railroad as to form and amount prior to beginning work on Railroad's right of way.
- F. All insurance herein before specified shall be carried until the final inspection and acceptance of the project by the Department and Railroad, or acceptance of that portion of the project within Railroad's right of way. At this point, no work or any other activities by the Contractor shall take place in Railroad's right of way without written permission from both the Department and Railroad.

15. FAILURE TO COMPLY:

- A. In the event the Contractor violates or fails to comply with any of the requirements of these Special Provisions:
- (1) The Railroad Engineer may require that the Contractor vacate Railroad's property.
 - (2) The Department Engineer may withhold all monies due the Contractor on monthly statements.

Any such orders shall remain in effect until the Contractor has remedied the situation to the satisfaction of the Department Engineer and the Railroad Engineer.

16. PAYMENT FOR COST OF COMPLIANCE:

No separate payment will be made for any extra cost incurred on account of compliance with these special provisions. All such cost shall be included in the various prices bid to perform the work.

17. COMPLETION AND ACCEPTANCE:

Upon completion of the work, the Contractor shall remove from within the limits of the Railroad's right of way all machinery, equipment, surplus materials, rubbish or temporary buildings of the Contractor, and leave said right of way in a neat and orderly condition. After the final inspection has been made and work found to be completed in a satisfactory manner acceptable to the Department and Railroad, the Department will be notified of the Railroad's acceptance in writing by the Railroad's Chief Engineer or his authorized representative within ten (10) days or as soon thereafter as practicable.

Railroad Site Data:

The following information was received from the Railroad, and is provided as a convenience to the Contractor in bidding this project. This information is subject to change and the Contractor may, at his discretion, contact the Railroad directly to verify its current accuracy. Since this information is shown as a convenience to the Contractor, but is subject to change, the Contractor shall have no claims whatsoever against either the Railroad or the Department of Transportation for any delays or additional costs incurred based on changes in this information which occur after the above date of receipt.

Type and number of tracks within 50 ft. of project (mainline, branchline, siding, yard, etc.).

1 – Mainline

Number of trains on affected track per day.

2 – Freight

Maximum authorized operating speed of trains.

10 mph

PROJECT SPECIAL PROVISION

(10-18-95) (Rev. 10-15-13)

Z-1

PERMITS

The Contractor's attention is directed to the following permits, which have been issued to the Department of Transportation by the authority granting the permit.

<u>PERMIT</u>	<u>AUTHORITY GRANTING THE PERMIT</u>
Dredge and Fill and/or Work in Navigable Waters (404)	U. S. Army Corps of Engineers
Water Quality (401)	Division of Environmental Management, NCDEQ State of North Carolina

The Contractor shall comply with all applicable permit conditions during construction of this project. Those conditions marked by * are the responsibility of the Department and the Contractor has no responsibility in accomplishing those conditions.

Agents of the permitting authority will periodically inspect the project for adherence to the permits.

The Contractor's attention is also directed to Articles 107-10 and 107-13 of the *2012 Standard Specifications* and the following:

Should the Contractor propose to utilize construction methods (such as temporary structures or fill in waters and/or wetlands for haul roads, work platforms, cofferdams, etc.) not specifically identified in the permit (individual, general, or nationwide) authorizing the project it shall be the Contractor's responsibility to coordinate with the Engineer to determine what, if any, additional permit action is required. The Contractor shall also be responsible for initiating the request for the authorization of such construction method by the permitting agency. The request shall be submitted through the Engineer. The Contractor shall not utilize the construction method until it is approved by the permitting agency. The request normally takes approximately 60 days to process; however, no extensions of time or additional compensation will be granted for delays resulting from the Contractor's request for approval of construction methods not specifically identified in the permit.

Where construction moratoriums are contained in a permit condition which restricts the Contractor's activities to certain times of the year, those moratoriums will apply only to the portions of the work taking place in the waters or wetlands provided that activities outside those areas is done in such a manner as to not affect the waters or wetlands.

DEPARTMENT OF THE ARMY PERMIT

Permittee: NCDOT SR 3000 (IDOLS ROAD) EXTENSION TIP U-27007
ATTN: DR. GREGORY J. THORPE, PH.D.

Permit No.: SAW-1998-20439

Issuing Office: USAED, WILMINGTON – CESA W-RG-R

NOTE: The term "you" and its derivatives, as used in this permit, means the permittee or any future transferee. The term "this office" refers to the appropriate district or division office of the Corps of Engineers having jurisdiction over the permitted activity or the appropriate official of that office acting under the authority of the commanding officer.

You are authorized to perform work in accordance with the terms and conditions specified below.

Project Description: The North Carolina Department of Transportation (NCDOT) has identified this project as TIP U-2707, which involves the construction of a 2.0 mile roadway on new location, as well as the replacement of bridge no. 109 over the Norfolk Southern Railroad and reconfiguration of the intersection of Idols and Hampton Roads. The cross section of the proposed new location facility consists of two 12 ft. travel lanes, 4 ft. paved shoulder to accommodate bicycles, and 4 ft. grass shoulders. The project would permanently impact 903 linear feet of the jurisdictional stream channels of Muddy Creek and two unnamed tributaries to Muddy Creek. In addition, impacts are proposed to 0.81 acre of jurisdictional wetlands adjacent to these tributaries. To mitigate for all unavoidable permanent impacts to jurisdictional features, the applicant proposes compensatory mitigation for 892 linear feet of permanent stream impacts (not including bank stabilization) and 0.81 acre of permanent riparian wetland impacts. On-site stream restoration and enhancement will be performed by NCDOT to compensate for all 892 linear feet of permanent stream impacts at a 1:1 ratio. The USACE is requiring all 892 feet of mitigation. The remaining compensatory mitigation for 0.81 acre of permanent riparian wetland impacts will be provided by North Carolina Ecosystem Enhancement Program (NCEEP) to satisfy the compensatory mitigation requirements associated with federal and state permits. In a letter dated March 6, 2010, NCEEP has agreed to provide the required wetland mitigation for this proposal if permitted.

Project Location: The project, known as TIP U-²⁷⁰⁷~~27027~~, is a 2.0 mile roadway on new location, as well as the replacement of bridge no. 109 over the Norfolk Southern Railroad and the reconfiguration of the intersection of Idols and Hampton Roads. The cross section of the proposed new location facility consists of two 12 ft. travel lanes, 4 ft. paved shoulders to accommodate bicycles, and 4 ft. grass shoulders. Impacts are proposed to Muddy Creek and two unnamed tributaries to Muddy Creek. In addition, impacts are proposed to 0.81 acre of jurisdictional wetlands adjacent to these tributaries. All project streams are tributaries to the Yadkin-Pee Dee River Basin in Forsyth County. (U.S. Geological Survey [USGS] Hydrologic Unit [HUC] 03040101). The approximate center of project is at 36.0124° N., -80.3586° W.

Permit Conditions:

General Conditions:

1. The time limit for completing the work authorized ends on December 31, 2019. If you find that you need more time to complete the authorized activity, submit your request for a time extension to this office for consideration at least one month before the above date is reached.
2. You must maintain the activity authorized by this permit in good condition and in conformance with the terms and conditions of this permit. You are not relieved of this requirement if you abandon the permitted activity, although you may make a good faith transfer to a third party in compliance with General Condition 4 below. Should you wish to cease to maintain the authorized activity or should you desire to abandon it without a good faith transfer, you must obtain a modification of this permit from this office, which may require restoration of the area.
3. If you discover any previously unknown historic or archeological remains while accomplishing the activity authorized by this permit, you must immediately notify this office of what you have found. We will initiate the Federal

and state coordination required to determine if the remains warrant a recovery effort or if the site is eligible for listing in the National Register of Historic Places.

4. If you sell the property associated with this permit, you must obtain the signature of the new owner in the space provided and forward a copy of the permit to this office to validate the transfer of this authorization.

5. If a conditioned water quality certification has been issued for your project, you must comply with the conditions specified in the certification as special conditions to this permit. For your convenience, a copy of the certification is attached if it contains such conditions.

6. You must allow representatives from this office to inspect the authorized activity at any time deemed necessary to ensure that it is being or has been accomplished in accordance with the terms and conditions of your permit,

Special Conditions:

SEE ATTACHED SPECIAL CONDITIONS

Further Information:

1. **Congressional Authorities:** You have been authorized to undertake the activity described above pursuant to:

Section 10 of the Rivers and Harbors Act of 1899 (33 U.S.C. 403).

Section 404 of the Clean Water Act (33 U.S.C. 1344).

Section 103 of the Marine Protection, Research and Sanctuaries Act of 1972 (33 U.S.C. 1413).

2. **Limits of this authorization.**

a. This permit does not obviate the need to obtain other Federal, state, or local authorizations required by law.

b. This permit does not grant any property rights or exclusive privileges.

c. This permit does not authorize any injury to the property or rights of others.

d. This permit does not authorize interference with any existing or proposed Federal project.

3. **Limits of Federal Liability.** In issuing this permit, the Federal Government does not assume any liability for the following:

a. Damages to the permitted project or uses thereof as a result of other permitted or unpermitted activities or from natural causes.

b. Damages to the permitted project or uses thereof as a result of current or future activities undertaken by or on behalf of the United States in the public interest.

c. Damages to persons, property, or to other permitted or unpermitted activities or structures caused by the activity authorized by this permit.

d. Design or construction deficiencies associated with the permitted work.

- e. Damage claims associated with any future modification, suspension, or revocation of this permit.**
- 4. Reliance on Applicant's Data: The determination of this office that issuance of this permit is not contrary to the public interest was made in reliance on the information you provided.**
- 5. Reevaluation of Permit Decision. This office may reevaluate its decision on this permit at any time the circumstances warrant. Circumstances that could require a reevaluation include, but are not limited to, the following:**
 - a. You fail to comply with the terms and conditions of this permit.**
 - b. The information provided by you in support of your permit application proves to have been false, incomplete, or inaccurate (See 4 above).**
 - c. Significant new information surfaces which this office did not consider in reaching the original public interest decision.**

Such a reevaluation may result in a determination that it is appropriate to use the suspension, modification, and revocation procedures contained in 33 CFR 325.7 or enforcement procedures such as those contained in 33 CFR 326.4 and 326.5. The referenced enforcement procedures provide for the issuance of an administrative order requiring you to comply with the terms and conditions of your permit and for the initiation of legal action where appropriate. You will be required to pay for any corrective measures ordered by this office, and if you fail to comply with such directive, this office may in certain situations (such as those specified in 33 CFR 209.170) accomplish the corrective measures by contract or otherwise and bill you for the cost.

6. Extensions. General condition 1 establishes a time limit for the completion of the activity authorized by this permit, Unless there are circumstances requiring either a prompt completion of the authorized activity or a reevaluation of the public interest decision, the Corps will normally give favorable consideration to a request for an extension of this time limit.

P-5

Your signature below, as permittee, indicates that you accept and agree to comply with the terms and conditions of this permit.

E. J. Lusk for Oct 31, 2012
(PERMITTEE) NCDOT SR 3000 (IDOLS ROAD) TIP U-2707 (DATE)
DR.GREGORY J. THORPE, PH.D.

This permit becomes effective when the Federal official, designated to act for the Secretary of the Army, has signed below.

M. Baker 11/06/12
(DISTRICT Engineer) STEVEN A. BAKER, COLONEL (DATE)

When the structures or work authorized by this permit are still in existence at the time the property is transferred, the terms and conditions of this permit will continue to be binding on the new owner(s) of the property. To validate the transfer of this permit and the associated liabilities associated with compliance with its terms and conditions, have the transferee sign and date below.

(Transferee) (DATE)

SPECIAL CONDITIONS: ACTION ID: SAW-1998-20439
NCDOT SR 3000 (Idols Road) TIP U-2707

Failure to institute and carry out the details of the following special conditions below (listed as a-w) will result in a directive to cease all ongoing and permitted work within waters of the United States, including wetlands, associated with the permitted project, or such other remedies and/or fines as the U.S. Army Corps of Engineers District Commander or his authorized representatives may seek.

- a) The North Carolina Division of Water Quality (DWQ) permit/certification number WQC003938 was issued for this project on August 6, 2012. Special conditions were issued associated with this water quality permit/certification and a copy of these conditions is attached as (Exhibit A). These referenced conditions are hereby incorporated as special conditions of this permit.
- b) All work authorized by this permit must be performed in strict compliance with the attached plans which were received on May 9, 2012. These plans are a part of this permit and identified as (Exhibit B). Any modification to these plans must be approved by the US Army Corps of Engineers (USACE) prior to implementation.
- * c) The permittee shall schedule a preconstruction meeting between its representatives, the contractor's representatives, and the Corps of Engineers, Raleigh Regulatory Field Office, NCDOT Regulatory Project Manager, prior to any work within jurisdictional waters and wetlands to ensure that there is a mutual understanding of all of the terms and conditions contained within this Department of the Army Permit. The permittee shall provide the USACE, Raleigh Regulatory Field Office, NCDOT Regulatory Project Manager, with a copy of the final plans at least two weeks prior to the preconstruction meeting along with a description of any changes that have been made to the project's design, construction methodology or construction timeframe. The permittee shall schedule the preconstruction meeting for a time when the USACE and North Carolina Division of Water Quality (NCDWQ) Project Managers can attend. The permittee shall invite the Corps and NCDWQ Project Managers a minimum of thirty (30) days in advance of the scheduled meeting in order to provide those individuals with ample opportunity to schedule and participate in the required meeting.
- d) Except as authorized by this permit or any USACE approved modification to this permit, no excavation, fill or mechanized land-clearing activities shall take place at any time in the construction or maintenance of this project, within waters or wetlands. This permit does not authorize temporary placement or double handling of excavated or fill material within waters or wetlands outside the permitted area. This prohibition applies to all borrow and fill activities connected with this project.
- e) Except as specified in the plans attached to this permit, no excavation, fill or mechanized land-clearing activities shall take place at any time in the construction or maintenance of this project, in such a manner as to impair normal flows and circulation patterns within waters or wetlands or to reduce the reach of waters or wetlands.

SPECIAL CONDITIONS: ACTION ID: SAW-1998-20439
NCDOT SR 3000 (Idols Road) TIP U-2707

- f) Compensatory mitigation for the unavoidable impacts to 892 (not including mitigation for 11 feet of stream bank stabilization included in the requested 903 linear feet of stream channel impacts) linear feet of stream impact associated with the proposed project shall be provided by on-site stream restoration and enhancement to be performed by NCDOT at a 1:1 ratio. The on-site mitigation will be constructed and in compliance with the attached U-2707 Stream Mitigation Plan dated December 22, 2012 and identified as (Exhibit C).
- * Compensatory mitigation for 0.81 acre of permanent Riparian-Nonriverine wetland impacts associated with the project will be provided by North Carolina Ecosystem Enhancement Program (NCEEP), as outlined in the letter dated March 6, 2012, from Michael Ellison, EEP Deputy Director. In order to compensate for this wetland impact associated with this permit, mitigation shall be provided in accordance with the provisions outlined on the most recent version of the attached Compensatory Mitigation Responsibility Transfer Form. The requirements of this form, including any special conditions listed on this form, are hereby incorporated as special conditions of this permit authorization and identified as (Exhibit D).
- g) All mechanized equipment will be regularly inspected and maintained to prevent contamination of waters and wetlands from fuels, lubricants, hydraulic fluids, or other toxic materials. In the event of a spill of petroleum products or any other hazardous waste, the permittee shall immediately report it to the N.C. Division of Water Quality at 1 (800) 858-0368 and provisions of the North Carolina Oil Pollution and Hazardous Substances Control Act will be followed.
- * h) The permittee shall advise the Corps in writing prior to beginning the work authorized by this permit and again upon completion of the work authorized by this permit.
- i) Unless otherwise authorized by this permit, all fill material placed in waters or wetlands shall be generated from an upland source and will be clean and free of any pollutants except in trace quantities. Metal products, organic materials (including debris from land clearing activities), or unsightly debris will not be used.
- j) The permittee shall require its contractors and/or agents to comply with the terms and conditions of this permit in the construction and maintenance of this project, and shall provide each of its contractors and/or agents associated with the construction or maintenance of this project with a copy of this permit. A copy of this permit, including all conditions, shall be available at the project site during construction and maintenance of this project

SPECIAL CONDITIONS: ACTION ID: SAW-1998-20439
NCDOT SR 3000 (Idols Road) TIP U-2707

- k) The permittee shall employ all sedimentation and erosion control measures necessary to prevent an increase in sedimentation or turbidity within waters and wetlands outside the permit area. This shall include, but is not limited to, the immediate installation of silt fencing or similar appropriate devices around all areas subject to soil disturbance or the movement of earthen fill, and the immediate stabilization of all disturbed areas. Additionally, the project must remain in full compliance with all aspects of the Sedimentation Pollution Control Act of 1973 (North Carolina General Statutes Chapter 113A Article 4).
- l) The permittee shall remove all sediment and erosion control measures placed in wetlands or waters, and shall restore natural grades in those areas, prior to project completion.
- m) During the clearing phase of the project, heavy equipment must not be operated in surface waters or stream channels. Temporary stream crossings will be used to access the opposite sides of stream channels. All temporary diversion channels and stream crossings will be constructed of non-erodible materials. Grubbing of riparian vegetation will not occur until immediately before construction begins on a given segment of stream channel.
- n) No fill or excavation for the purposes of sedimentation and erosion control shall occur within jurisdictional waters, including wetlands, unless it is included on the plan drawings and specifically authorized by this permit.
- o) The permittee, upon receipt of a notice of revocation of this permit or upon its expiration before completion of the work will, without expense to the United States and in such time and manner as the Secretary of the Army or his authorized representative may direct, restore the water or wetland to its pre-project condition.
- p) Violations of these conditions or violations of Section 404 of the Clean Water Act or Section 10 of the Rivers and Harbors Act must be reported in writing to the Wilmington District U.S. Army Corps of Engineers within 24 hours of the permittee's discovery of the violation.
- * q) The permittee will ensure that the construction design plans for this project do not deviate from the permit plans attached to this authorization. Written verification shall be provided that the final construction drawings comply with the attached permit drawings prior to any active construction in waters of the United States, including wetlands. Any deviation in the construction design plans will be brought to the attention of the Corps of Engineers, Raleigh Regulatory Field Office prior to any active construction in waters or wetlands.

SPECIAL CONDITIONS: ACTION ID: SAW-1998-20439
NCDOT SR 3000 (Idols Road) TIP U-2707

- * r) Prior to commencing construction within jurisdictional waters of the United States for any portion of the proposed project, the permittee shall forward the latest version of project construction drawings to the Corps of Engineers, Raleigh Regulatory Field Office NCDOT Regulatory Project Manager. Half-size drawings will be acceptable.

- s) The permittee shall take measures to prevent live or fresh concrete from coming into contact with any surface waters until the concrete has hardened.

- t) Measures will be included in the construction/installation that will promote the safe passage of fish and other aquatic organisms. The dimension, pattern, and profile of the stream above and below a pipe or culvert should not be modified by widening the stream channel or by reducing the depth of the stream in connection with the construction activity. The width, height, and gradient of a proposed opening should be such as to pass the average historical low flow and spring flow without adversely altering flow velocity. Spring flow should be determined from gauge data, if available. In the absence of such data, bankfull flow can be used as a comparable level.

- u) Culverts greater than 48 inches in diameter will be buried at least one foot below the bed of the stream. Culverts 48 inches in diameter or less shall be buried or placed on the stream bed as practicable and appropriate to maintain aquatic passage, and every effort shall be made to maintain the existing channel slope. The bottom of the culvert must be placed at a depth below the natural stream bottom to provide for passage during drought or low flow conditions. Destabilizing the channel and head cutting upstream should be considered in the placement of the culvert. A waiver from the depth specifications in this condition may be requested in writing. The waiver will be issued if it can be demonstrated that the proposal would result in the least impacts to the aquatic environment.

- v) To ensure that all borrow and waste activities occur on high ground and do not result in the degradation of adjacent wetlands and streams, except as authorized by this permit, the permittee shall require its contractors and/or agents to identify all areas to be used to borrow material, or to dispose of dredged, fill, or waste material. The permittee shall provide the USACE with appropriate maps indicating the locations of proposed borrow or waste sites as soon as the permittee has that information. The permittee will coordinate with the USACE before approving any borrow or waste sites that are within 400 feet of any streams or wetlands.

- w) If the permittee discovers any previously unknown historic or archaeological sites while accomplishing the authorized work, he shall immediately stop work and notify the Corps of Engineers, Raleigh Regulatory Field Office NCDOT Regulatory Project Manager who will initiate the required State/Federal coordination.



North Carolina Department of Environment and Natural Resources

Division of Water Quality
Charles Wakild, P.E.
Director

Beverly Eaves Perdue
Governor

Dee Freeman
Secretary

August 6, 2012

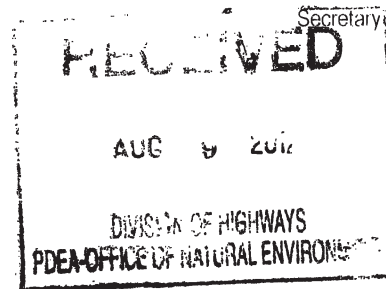

Dr. Greg Thorpe, PhD., Manager
Project Development and Environmental Analysis
North Carolina Department of Transportation
1548 Mail Service Center
Raleigh, North Carolina, 27699-1548

Subject: 401 Water Quality Certification Pursuant to Section 401 of the Federal Clean Water Act with
ADDITIONAL CONDITIONS for Proposed extension of SR 3000 (Idols Rd) from SR 2999 (Hampton
Road) to US 158 (Clemmons Road) in Forsyth County, Federal Aid Project No. STP-3000 (1), State
Project No. 8.2624101, TIP U-2707.
NCDWQ Project No. 2012-0470

Dear Dr. Thorpe:

Attached hereto is a copy of Certification No. 003938 issued to The North Carolina Department of Transportation (NCDOT) dated August 6, 2012.

If we can be of further assistance, do not hesitate to contact us.

Sincerely,

A handwritten signature in black ink, appearing to read "Charles Wakild". Below the signature, the name "Charles Wakild" and the title "Director" are printed in a standard font. There is a small handwritten mark to the left of the name.

Attachments

- cc: John Thomas, US Army Corps of Engineers, Raleigh Field Office (electronic copy only)
- Kent Boyer, Division 9 Environmental Officer (electronic copy only)
- Chris Militscher, Environmental Protection Agency (electronic copy only)
- Marla Chambers, NC Wildlife Resources Commission
- Jason Elliott, NCDOT, Roadside Environmental Unit (electronic copy only)
- Beth Harmon, Ecosystem Enhancement Program (electronic copy only)
- Wetlands/401 Transportation Unit
- File Copy

P-11

401 Water Quality Certification Pursuant to Section 401 of the Federal Clean Water Act with ADDITIONAL CONDITIONS

THIS CERTIFICATION is issued in conformity with the requirements of Section 401 Public Laws 92-500 and 95-217 of the United States and subject to the North Carolina Division of Water Quality (NCDWQ) Regulations in 15 NCAC 2H .0500. This certification authorizes the NCDOT to impact 0.81 acres of jurisdictional wetlands, and 903 linear feet of jurisdictional streams Forsyth County. The project shall be constructed pursuant to the application dated received May 10, 2012 with additional information dated received June 25, 2012 and July 17, 2012. The authorized impacts are as described below:

Stream Impacts in the Yadkin-Pee Dee River Basin

Site	Permanent Fill in Intermittent Stream (linear ft)	Temporary Fill in Intermittent Stream (linear ft)	Permanent Fill in Perennial Stream (linear ft)	Temporary Fill in Perennial Stream (linear ft)	Total Stream Impact (linear ft)	Stream Impacts Requiring Mitigation (linear ft)
2	61				61	
3			831		831	831
6			11		11	
Total	61		842		903	831

Total Stream Impact for Project: 903 linear feet

Wetland Impacts in the Yadkin River Basin (riverine)

Site	Fill (ac)	Fill (temporary) (ac)	Excavation (ac)	Mechanized Clearing (ac)	Hand Clearing (ac)	Area under Bridge (ac)	Total Wetland Impact (ac)
1				0.03			0.03
4	0.78						0.78
Total	0.78			0.03			0.81

Total Wetland Impact for Project: 0.81 acres.

The application provides adequate assurance that the discharge of fill material into the waters of the Yadkin-Pee Dee River Basin in conjunction with the proposed development will not result in a violation of applicable Water Quality Standards and discharge guidelines. Therefore, the State of North Carolina certifies that this activity will not violate the applicable portions of Sections 301, 302, 303, 306, 307 of PL 92-500 and PL 95-217 if conducted in accordance with the application and conditions hereinafter set forth.

This approval is only valid for the purpose and design that you submitted in your application dated received May 10, 2012 with additional information dated received June 25, 2012 and July 17, 2012. Should your project change, you are required to notify the NCDWQ and submit a new application. If the property is sold, the new owner must be given a copy of this Certification and approval letter, and is thereby responsible for complying with all the conditions. If any additional wetland impacts, or stream impacts, for this project (now or in the future) exceed one acre or 150 linear feet, respectively, additional compensatory mitigation may be required as described in 15A NCAC 2H .0506 (h) (6) and (7). For this approval to remain valid, you are required to comply with all the conditions listed below. In addition, you should obtain all other federal, state or local permits before proceeding with your project including (but not limited to) Sediment and Erosion control, Coastal Stormwater, Non-discharge and Water Supply watershed regulations. This Certification shall expire on the same day as the expiration date of the corresponding Corps of Engineers Permit.

Condition(s) of Certification:

- *1. The NCDOT Division Environmental Officer or Environmental Assistant will conduct a pre-construction meeting with all appropriate staff to ensure that the project supervisor and essential staff understand the potential issues with the stream mitigation site. NCDWQ staff shall be invited to the pre-construction meeting.
2. Compensatory mitigation for impacts to 831 linear feet of streams at a replacement ratio of 1:1 is required. Compensatory mitigation for impacts to jurisdictional streams shall be provided by onsite stream relocation and

restoration (1:1 ratio) of 1800 linear feet of Stream S-JH-A ('Reach 1') and by on-site enhancement (2:1) of 153 linear feet of Stream S-JH-B ('Reach 2'), generating 1876.5 stream mitigation credits. The onsite stream relocation shall be constructed in accordance with the design submitted in your May 10, 2012 application and additional information dated received electronically on June 25, 2012. All on-site mitigation sites shall be protected in perpetuity by a conservation easement or through NCDOT fee simple acquisition and recorded in the NCDOT Natural Environment Unit mitigation geodatabase. Please be reminded that as-builts for the completed streams shall be submitted to the North Carolina Division of Water Quality 401 Wetlands Unit with the as-builts for the rest of the project. If the parameters of this condition are not met, then the permittee shall supply additional stream mitigation for the 831 linear feet of impacts. All channel relocations will be constructed in a dry work area, will be completed and stabilized, and must be approved on site by NCDWQ staff, prior to diverting water into the new channel. Whenever possible, channel relocations shall be allowed to stabilize for an entire growing season. All stream relocations shall have a 50-foot wide native wooded buffer planted on both sides of the stream unless otherwise authorized by this Certification. A transitional phase incorporating rolled erosion control product (RECP) and appropriate temporary ground cover is allowable.

3. The stream mitigation site shall be monitored annually for five years or until success criteria are satisfied. Monitoring protocols shall follow the Monitoring Level I outlined in the Stream Mitigation Guidelines, April 2003.
4. Success of the mitigation site shall be determined by NCDWQ during an on-site visit at or near the end of the monitoring period.
5. There are no temporary impacts permitted at this time. If temporary impacts are needed, a permit modification will be required.
6. Post-construction stormwater shall be designed as approved in the permit application. If any changes are made to the post-construction stormwater design, the Division of Water Quality shall be contacted for approval of the changes.
- * 7. Two copies of the final construction drawings shall be furnished to NCDWQ Central Office prior to the pre-construction meeting. The permittee shall provide written verification that the final construction drawings comply with the permit drawings contained in the application dated received May 10, 2012 with additional information dated received June 25, 2012 and July 17, 2012. Any deviations from the approved drawings are not authorized unless approved by the NC Division of Water Quality.
8. All channel relocations will be constructed in a dry work area and stabilized before stream flows are diverted. Channel relocations will be completed and stabilized, and must be approved on site by NCDWQ staff, prior to diverting water into the new channel. Whenever possible, channel relocations shall be allowed to stabilize for an entire growing season. Vegetation used for bank stabilization shall be limited to native woody species, and should include establishment of a 30 foot wide wooded and an adjacent 20 foot wide vegetated buffer on both sides of the relocated channel to the maximum extent practical. All stream banks shall be matted with coir fiber matting. Also, rip-rap may be allowed if it is necessary to maintain the physical integrity of the stream, but the applicant must provide written justification and any calculations used to determine the extent of rip-rap coverage requested. Once the stream has been turned into the new channel, it may be necessary to relocate stranded fish to the new channel to prevent fish kills.
9. The post-construction removal of any temporary bridge structures must return the project site to its preconstruction contours and elevations. The impacted areas shall be revegetated with appropriate native species.
10. Strict adherence to the most recent version of NCDOT's Best Management Practices For Bridge Demolition and Removal approved by the US Army Corps of Engineers is a condition of the 401 Water Quality Certification.
11. Bridge deck drains shall not discharge directly into the stream. Stormwater shall be directed across the bridge and pre-treated through site-appropriate means (grassed swales, pre-formed scour holes, vegetated buffers, etc.) before entering the stream. Please refer to the most current version of *Stormwater Best Management Practices*.
12. There shall be no bents in the water. If the bridge design changes, this permit shall be modified.
13. No drill slurry or water that has been in contact with uncured concrete shall be allowed to enter surface waters. This water shall be captured, treated, and disposed of properly.
14. Riprap shall not be placed in the active thalweg channel or placed in the streambed in a manner that precludes aquatic life passage. Bioengineering boulders or structures should be properly designed, sized and installed.
15. The stream channel shall be excavated no deeper than the natural bed material of the stream, to the maximum extent practicable. Efforts must be made to minimize impacts to the stream banks, as well as to vegetation responsible for maintaining the stream bank stability. Any applicable riparian buffer impact for access to stream channel shall be temporary and be revegetated with native riparian species.
16. Unless otherwise approved in this certification, placement of culverts and other structures in open waters and streams shall be placed below the elevation of the streambed by one foot for all culverts with a diameter greater than 48 inches, and 20 percent of the culvert diameter for culverts having a diameter less than 48 inches, to allow low flow passage of water and aquatic life. Design and placement of culverts and other structures including temporary erosion control measures shall not be conducted in a manner that may result in dis-equilibrium of wetlands or streambeds or banks, adjacent to or upstream and down stream of the above structures. The applicant

is required to provide evidence that the equilibrium is being maintained if requested in writing by NCDWQ. If this condition is unable to be met due to bedrock or other limiting features encountered during construction, please contact NCDWQ for guidance on how to proceed and to determine whether or not a permit modification will be required.

17. During the construction of the project, no staging of equipment of any kind is permitted in waters of the U.S., or protected riparian buffers.
18. The dimension, pattern and profile of the stream above and below the crossing shall not be modified. Disturbed floodplains and streams shall be restored to natural geomorphic conditions.
19. The use of rip-rap above the Normal High Water Mark shall be minimized. Any rip-rap placed for stream stabilization shall be placed in stream channels in such a manner that it does not impede aquatic life passage.
- * 20. The Permittee shall ensure that the final design drawings adhere to the permit and to the permit drawings submitted for approval.
21. All work in or adjacent to stream waters shall be conducted in a dry work area. Approved BMP measures from the most current version of NCDOT Construction and Maintenance Activities manual such as sandbags, rock berms, cofferdams and other diversion structures shall be used to prevent excavation in flowing water.
22. Heavy equipment shall be operated from the banks rather than in the stream channel in order to minimize sedimentation and reduce the introduction of other pollutants into the stream.
23. All mechanized equipment operated near surface waters must be regularly inspected and maintained to prevent contamination of stream waters from fuels, lubricants, hydraulic fluids, or other toxic materials.
24. No rock, sand or other materials shall be dredged from the stream channel except where authorized by this certification.
25. Discharging hydroseed mixtures and washing out hydroseeders and other equipment in or adjacent to surface waters is prohibited.
26. The permittee and its authorized agents shall conduct its activities in a manner consistent with State water quality standards (including any requirements resulting from compliance with §303(d) of the Clean Water Act) and any other appropriate requirements of State and Federal law. If NCDWQ determines that such standards or laws are not being met (including the failure to sustain a designated or achieved use) or that State or federal law is being violated, or that further conditions are necessary to assure compliance, NCDWQ may reevaluate and modify this certification.
27. All fill slopes located in jurisdictional wetlands shall be placed at slopes no flatter than 3:1, unless otherwise authorized by this certification.
28. A copy of this Water Quality Certification shall be maintained on the construction site at all times. In addition, the Water Quality Certification and all subsequent modifications, if any, shall be maintained with the Division Engineer and the on-site project manager.
29. The outside buffer, wetland or water boundary located within the construction corridor approved by this authorization shall be clearly marked by highly visible fencing prior to any land disturbing activities. Impacts to areas within the fencing are prohibited unless otherwise authorized by this certification.
30. The issuance of this certification does not exempt the Permittee from complying with any and all statutes, rules, regulations, or ordinances that may be imposed by other government agencies (i.e. local, state, and federal) having jurisdiction, including but not limited to applicable buffer rules, stormwater management rules, soil erosion and sedimentation control requirements, etc
31. The Permittee shall report any violations of this certification to the Division of Water Quality within 24 hours of discovery.
- * 32. Upon completion of the project (including any impacts at associated borrow or waste sites), the NCDOT Division Engineer shall complete and return the enclosed "Certification of Completion Form" to notify NCDWQ when all work included in the 401 Certification has been completed.
33. Native riparian vegetation must be reestablished in the riparian areas within the construction limits of the project by the end of the growing season following completion of construction.
34. There shall be no excavation from, or waste disposal into, jurisdictional wetlands or waters associated with this permit without appropriate modification. Should waste or borrow sites, or access roads to waste or borrow sites, be located in wetlands or streams, compensatory mitigation will be required since that is a direct impact from road construction activities.
35. Erosion and sediment control practices must be in full compliance with all specifications governing the proper design, installation and operation and maintenance of such Best Management Practices in order to protect surface waters standards:
 - a. The erosion and sediment control measures for the project must be designed, installed, operated, and maintained in accordance with the most recent version of the *North Carolina Sediment and Erosion Control Planning and Design Manual*.

- b. The design, installation, operation, and maintenance of the sediment and erosion control measures must be such that they equal, or exceed, the requirements specified in the most recent version of the *North Carolina Sediment and Erosion Control Manual*. The devices shall be maintained on all construction sites, borrow sites, and waste pile (spoil) projects, including contractor-owned or leased borrow pits associated with the project.
- c. For borrow pit sites, the erosion and sediment control measures must be designed, installed, operated, and maintained in accordance with the most recent version of the *North Carolina Surface Mining Manual*.
- d. The reclamation measures and implementation must comply with the reclamation in accordance with the requirements of the Sedimentation Pollution Control Act.

36. Sediment and erosion control measures shall not be placed in wetlands or waters unless otherwise approved by this Certification.

Violations of any condition herein set forth may result in revocation of this Certification and may result in criminal and/or civil penalties. This Certification shall become null and void unless the above conditions are made conditions of the Federal 404 and/or Coastal Area Management Act Permit. This Certification shall expire upon the expiration of the 404 or CAMA permit.

If you wish to contest any statement in the attached Certification you must file a petition for an administrative hearing. You may obtain the petition form from the office of Administrative hearings. You must file the petition with the office of Administrative Hearings within sixty (60) days of receipt of this notice. A petition is considered filed when it is received in the office of Administrative Hearings during normal office hours. The Office of Administrative Hearings accepts filings Monday through Friday between the hours of 8:00am and 5:00pm, except for official state holidays. The original and one (1) copy of the petition must be filed with the Office of Administrative Hearings.

The petition may be faxed-provided the original and one copy of the document is received by the Office of Administrative Hearings within five (5) business days following the faxed transmission. The mailing address for the Office of Administrative Hearings is:

Office of Administrative Hearings
6714 Mail Service Center
Raleigh, NC 27699-6714
Telephone: (919)-431-3000, Facsimile: (919)-431-3100

A copy of the petition must also be served on DENR as follows:

Mr. William Cary, General Counsel
Department of Environment and Natural Resources
1601 Mail Service Center

This the 6th day of August 2012

DIVISION OF WATER QUALITY



Charles Wakild
Director

STATE OF NORTH CAROLINA
DIVISION OF HIGHWAYS

FORSYTH COUNTY

LOCATION: CLEMMONS -SR 3000 (IDOLS ROAD), FROM SR 2999 (HAMPTON ROAD) TO US 158 (CLEMMONS ROAD)
TYPE OF WORK: GRADING, DRAINAGE, PAVING, STRUCTURES, SIGNING, AND SIGNALS

WETLAND & STREAM IMPACTS

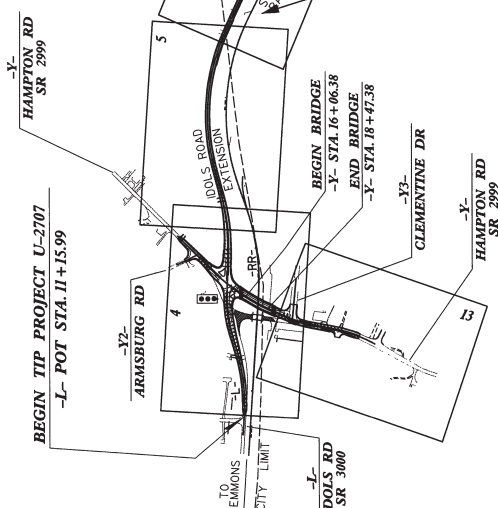
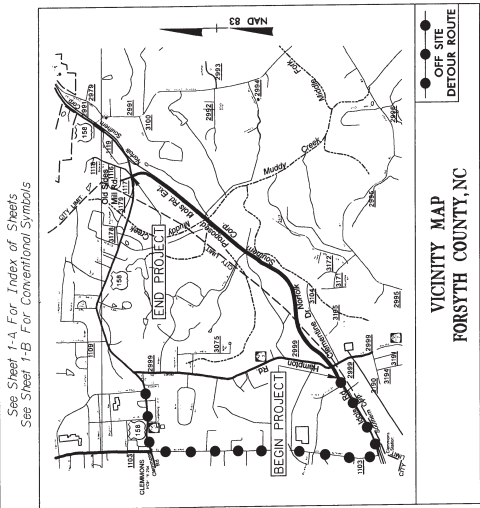

STATE	N.C.	STATE PROJECT REFERENCE NO.	U-2707	SHEET NO.	1	TOTAL SHEETS	1
NO. IN PROJECT	34845.1.1	P.A. PROJECT NO.	STP-3000(1)	DESCRIPTION	P.E.		
	34845.2.1		STP-3000(1)		R/W & UTIL.		
	34845.2.2						

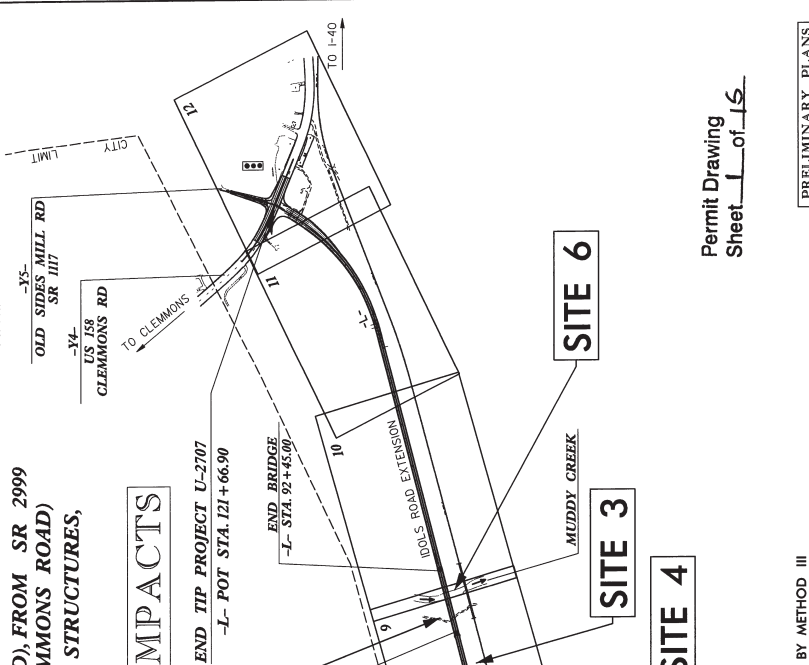

Permit Drawing
Sheet 1 of 16

PRELIMINARY PLANS
FOR THE USE OF CONSTRUCTION

CLEARING ON THIS PROJECT SHALL BE PERFORMED TO THE LIMITS ESTABLISHED BY METHOD III
A PORTION OF THIS PROJECT IS WITHIN THE MUNICIPAL BOUNDARIES OF CLEMMONS.

HYDRAULICS ENGINEER	STATE DESIGN ENGINEER	DATE
	ROADWAY DESIGN ENGINEER	
	FEDERAL HIGHWAY ADMINISTRATION	

PROJECT ENGINEER	PROJECT ENGINEER
BRIAN D. SPEIGHT, PE	BRYON M. PALMER, PE
PROJECT ENGINEER	PROJECT DESIGNER
FEBRUARY 18, 2005	NOVEMBER 21, 2006
RIGHT OF WAY DATE:	LETTING DATE:

PROJECT ENGINEER	PROJECT ENGINEER
CATHY S. HOUSER, PE	ENGINEERING COORDINATOR
NC DOT CONTACT	

Prepared in the Office of	2300 Revere Drive Raleigh, NC 27607 Tel: 919-799-8171 Fax: 919-799-8598
ENGINEERING GROUP	
ENGINEERING GROUP	

PROJECT LENGTH	ROADWAY TIP PROJECT U-2707 = 2.093 MILE
LENGTH ROADWAY TIP PROJECT U-2707 = 2.093 MILE	STRUCTURE TIP PROJECT U-2707 = 0.083 MILE
LENGTH STRUCTURE TIP PROJECT U-2707 = 0.083 MILE	TOTAL LENGTH TIP PROJECT U-2707 = 2.010 MILE
TOTAL LENGTH TIP PROJECT U-2707 = 2.010 MILE	NOTE: PROJECT LENGTH FOR U-2707 DETERMINED BY USING -L-

DESIGN DATA	ADT 2006 = 7800
ADT 2026 = 14467	DHV = 12 %
DHV = 12 %	D = 60 %
D = 60 %	T = 4 % *
T = 4 % *	V = 50 MPH
V = 50 MPH	* TST 1 % DUAL 3 %

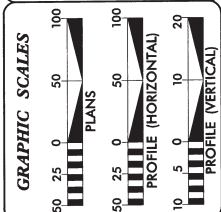

TIP PROJECT: U-2707

CONTRACT:

PROJECT REFERENCE NO.	U-2707
B.W. SHEET NO.	6
ROADWAY DESIGN ENGINEER	HYDRAULICS ENGINEER
INCOMPLETE PLANS	DO NOT USE FOR PERMITS OR ACCIDENTS
PRELIMINARY PLANS	FOR THE USE OF CONTRACTORS

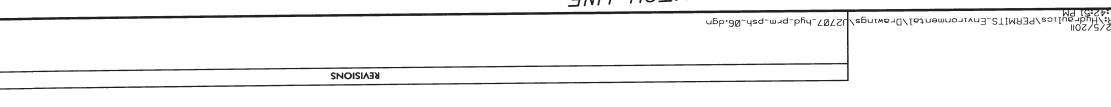
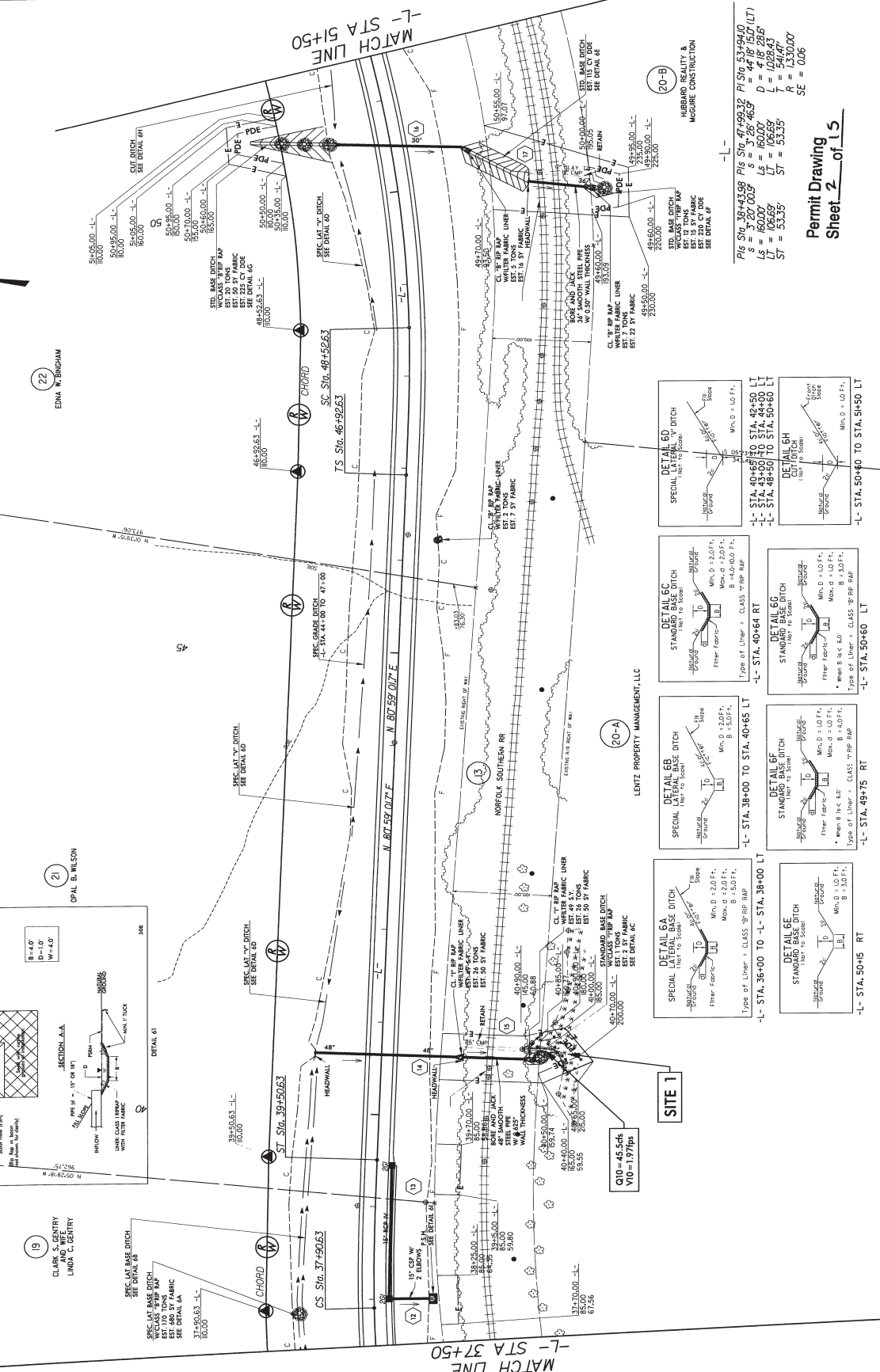
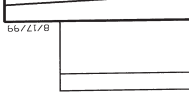
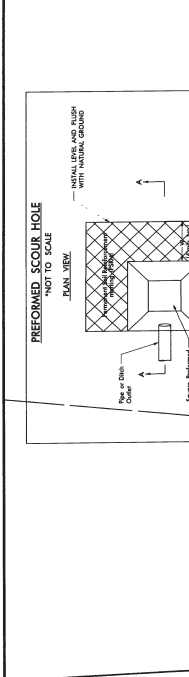
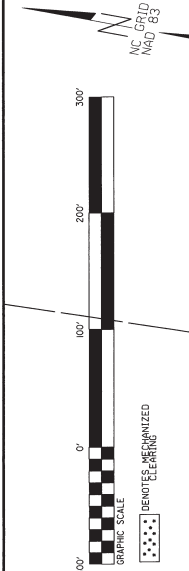

PIG STA. 38+43.98 PIS STA. 47+99.32 PIS STA. 53+94.00
 $s = 3' 20.000''$ $s = 3' 26.465''$ $s = 4' 18' 15.00'' (LT)$
 $Ls = 160.00'$ $Ls = 160.00'$ $D = 4' 18' 28.65''$
 $L = 166.667'$ $L = 166.667'$ $L = 166.667'$
 $ST = 35.355'$ $ST = 35.355'$ $ST = 35.355'$
 $SE = 0.06$

Permit Drawing
Sheet 2 of 15

REVISIONS

CLARA S. GENTRY AND WIFE LINDA G. GENTRY

OPAL B. WILSON

EDNA M. BINGHAM

LENTZ PROPERTY MANAGEMENT, LLC

HUBBARD REALTY & INSURANCE CONSTRUCTION

NC 87D MAD 83

15\"/>

15\"/>

15\"/>

15\"/>

15\"/>

15\"/>

15\"/>

15\"/>

15\"/>

15\"/>

15\"/>

15\"/>

15\"/>

15\"/>

15\"/>

15\"/>

15\"/>

15\"/>

15\"/>

15\"/>

15\"/>

15\"/>

15\"/>

15\"/>

15\"/>

15\"/>

15\"/>

15\"/>

15\"/>

15\"/>

15\"/>

15\"/>

15\"/>

15\"/>

15\"/>

15\"/>

15\"/>

15\"/>

15\"/>

15\"/>

15\"/>

15\"/>

15\"/>

15\"/>

15\"/>

15\"/>

15\"/>

15\"/>

15\"/>

15\"/>

15\"/>

15\"/>

15\"/>

15\"/>

15\"/>

15\"/>

15\"/>

15\"/>

15\"/>

15\"/>

15\"/>

15\"/>

15\"/>

15\"/>

15\"/>

15\"/>

15\"/>

15\"/>

15\"/>

15\"/>

15\"/>

15\"/>

15\"/>

15\"/>

15\"/>

15\"/>

15\"/>

15\"/>

15\"/>

15\"/>

15\"/>

15\"/>

15\"/>

15\"/>

15\"/>

15\"/>

15\"/>

15\"/>

15\"/>

15\"/>

15\"/>

15\"/>

15\"/>

15\"/>

15\"/>

15\"/>

15\"/>

15\"/>

15\"/>

15\"/>

15\"/>

15\"/>

15\"/>

15\"/>

15\"/>

15\"/>

15\"/>

15\"/>

15\"/>

15\"/>

15\"/>

15\"/>

15\"/>

15\"/>

15\"/>

15\"/>

15\"/>

15\"/>

15\"/>

15\"/>

15\"/>

15\"/>

15\"/>

15\"/>

15\"/>

15\"/>

15\"/>

15\"/>

15\"/>

15\"/>

15\"/>

15\"/>

15\"/>

15\"/>

15\"/>

15\"/>

15\"/>

15\"/>

15\"/>

15\"/>

15\"/>

15\"/>

15\"/>

15\"/>

15\"/>

15\"/>

15\"/>

15\"/>

15\"/>

15\"/>

15\"/>

15\"/>

15\"/>

15\"/>

15\"/>

15\"/>

PROJECT REFERENCE NO. U-2707
 RW SHEET NO. 6
 ROADWAY DESIGN ENGINEER
 HYDRAULICS ENGINEER

INCOMPLETE PLANS
 DO NOT USE FOR PERMITS
 PRELIMINARY PLANS
 DO NOT USE FOR CONTRACTOR

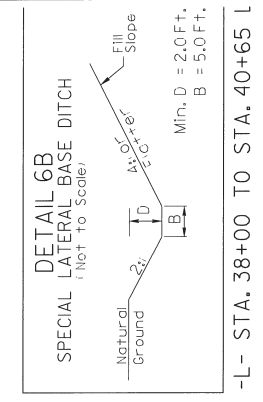
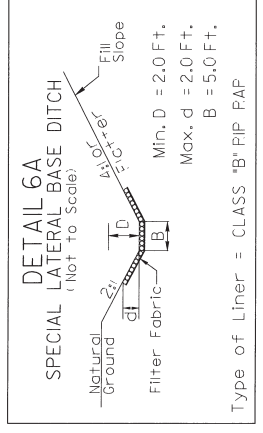
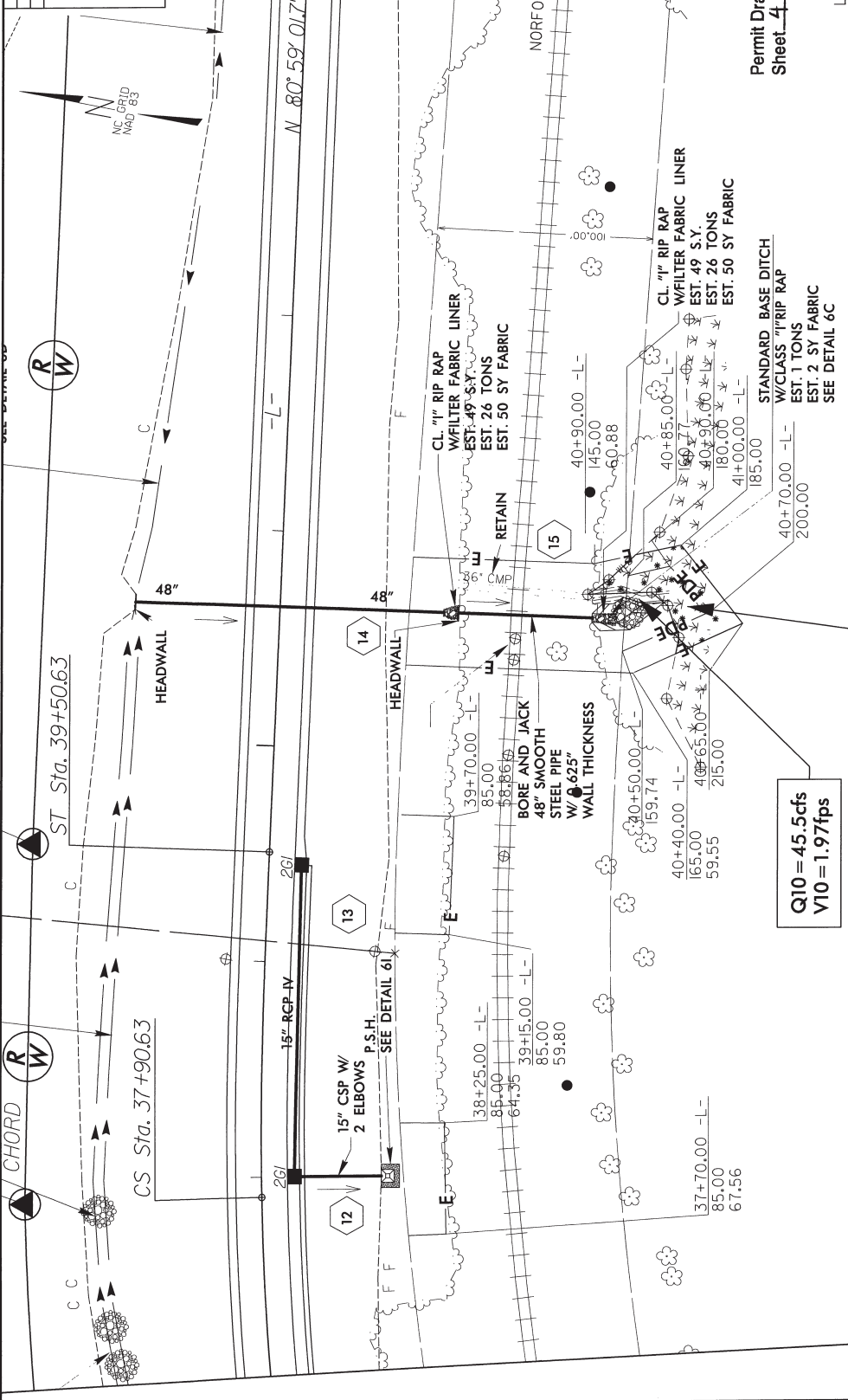

SITE 1

Q10 = 45.5cfs
V10 = 1.97fps

***** DENOTES MECHANIZED CLEARING



-L- STA. 36+00 TO -L- STA. 38+00 LT

-L- STA. 38+00 TO STA. 40+65 L

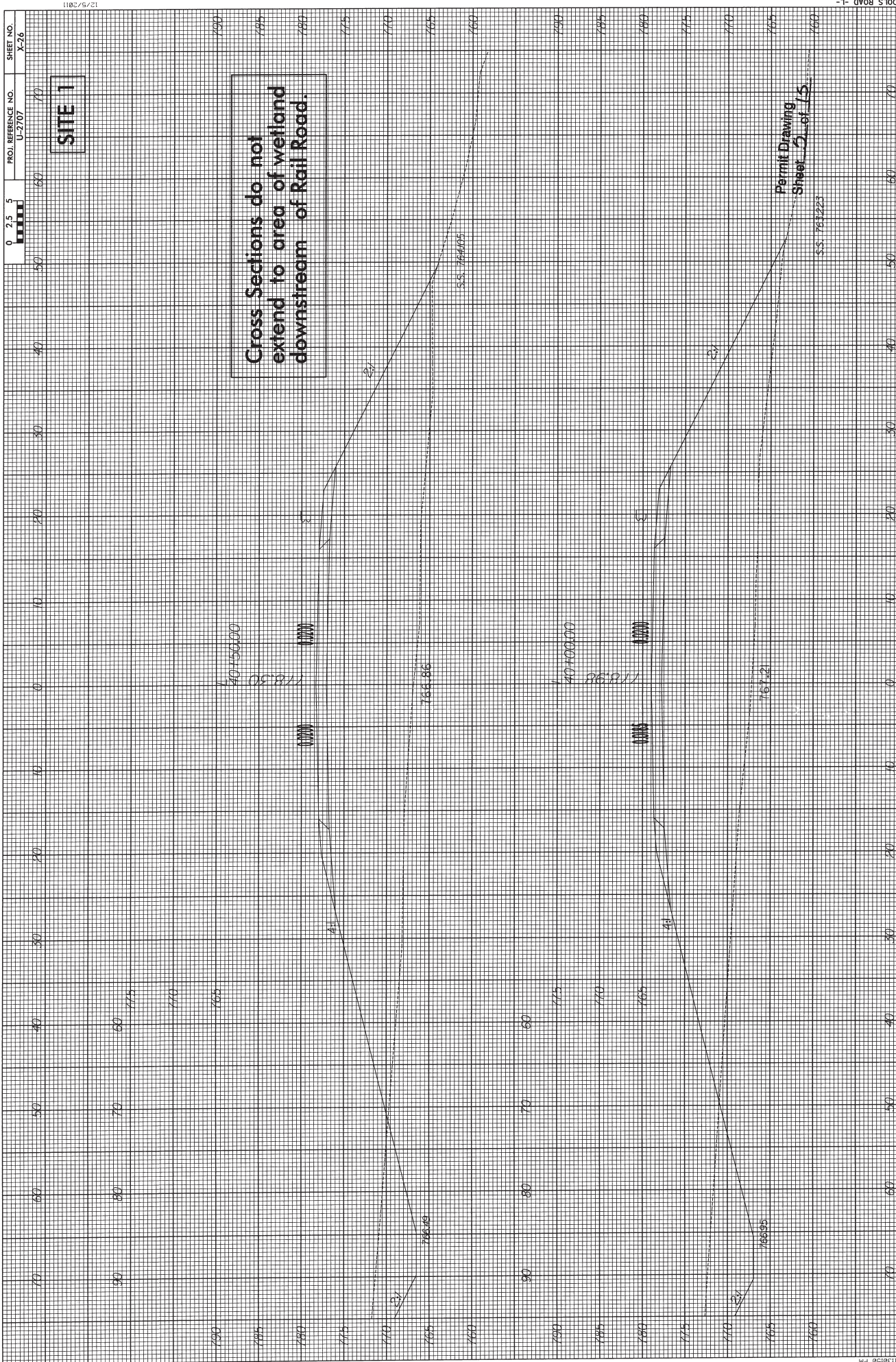

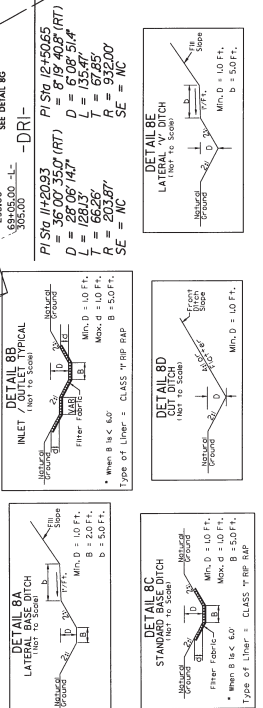
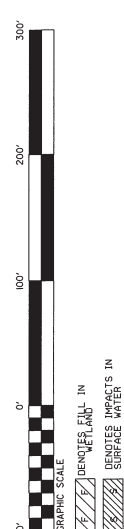
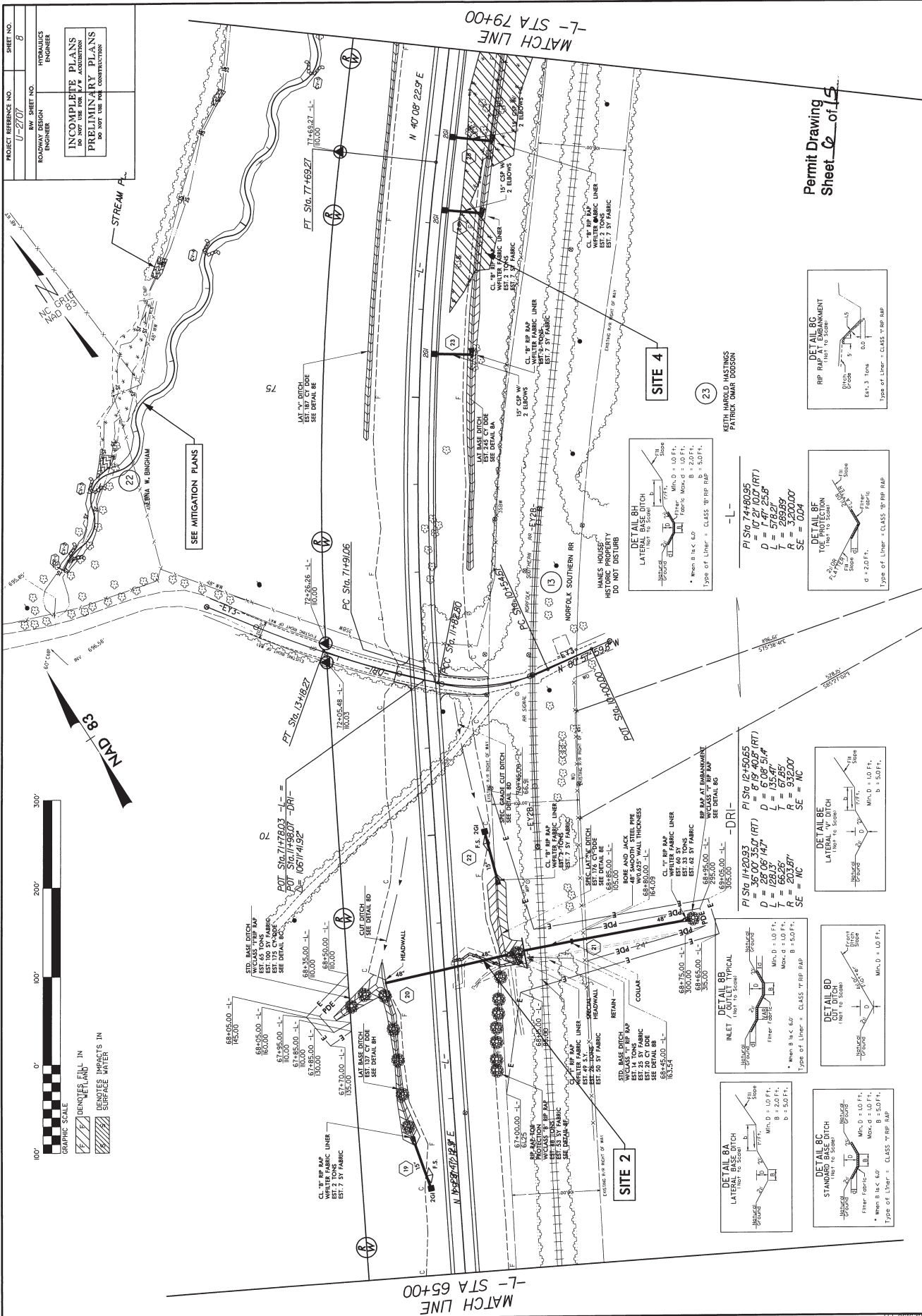

Permit Drawing
 Sheet 2 of 15

KEITH HAROLD HASTINGS
 PATRICK OMAR DOSSON



PROJECT REFERENCE NO.	U-2707	SHEET NO.	D
ROADWAY DESIGN ENGINEER		HYDRAULICS ENGINEER	
<p>INCOMPLETE PLANS DO NOT USE FOR PERMITS</p> <p>PRELIMINARY PLANS DO NOT USE FOR CONSTRUCTION</p>			

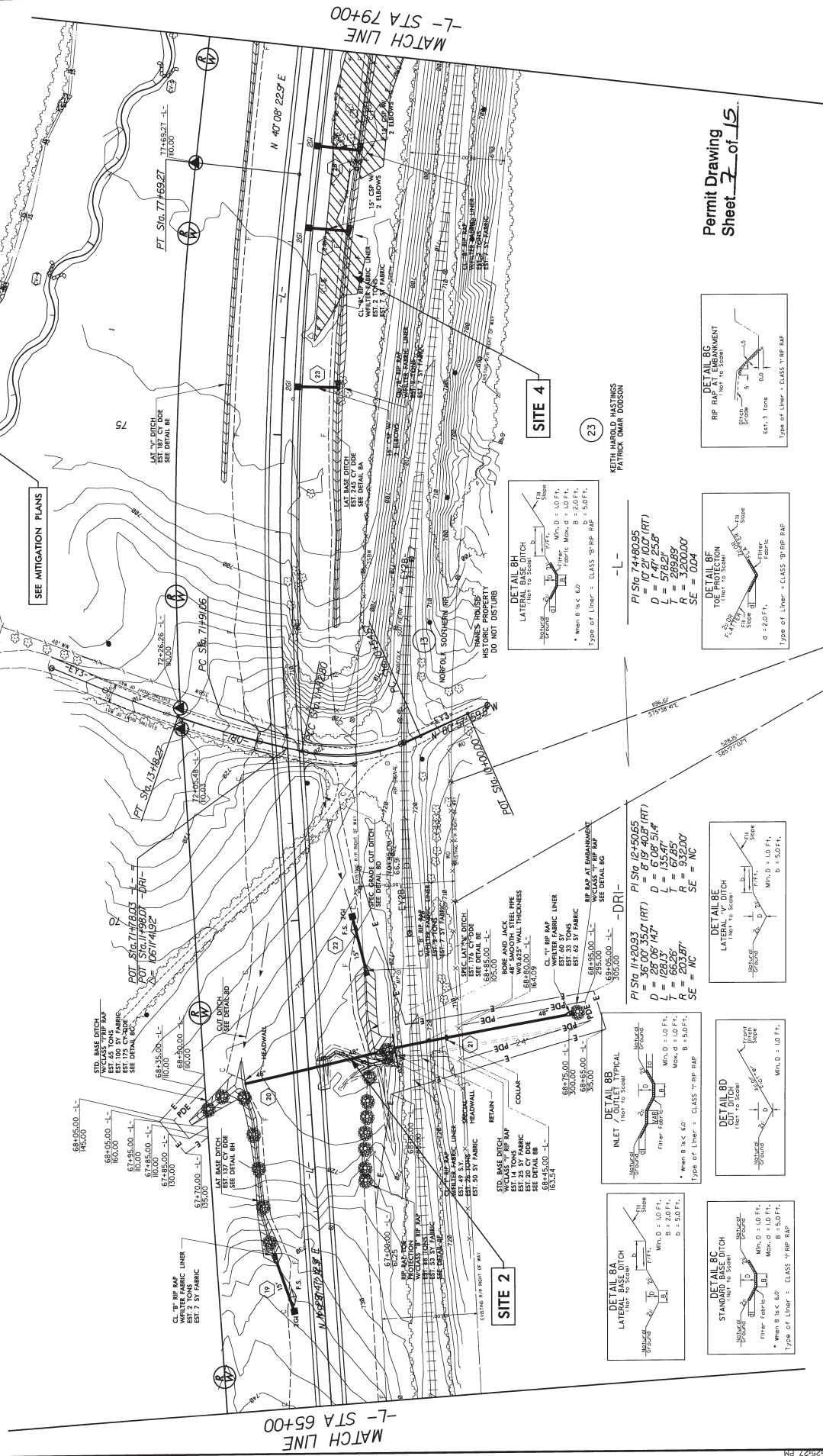
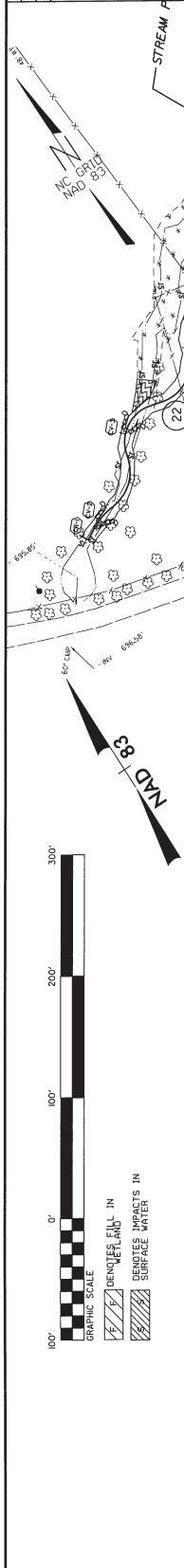

PI Sta 74+80.95
 D = 10.21' (3.107 RT)
 L = 578.26'
 T = 289.89'
 R = 3,200.00'
 SE = 0.04

PI Sta 12+50.65
 D = 819.02' (RT)
 L = 135.47'
 T = 67.85'
 R = 932.00'
 SE = 11.00'

PI Sta 11+20.93
 D = 56.00' (RT)
 L = 228.15'
 T = 66.26'
 R = 203.87'
 SE = 11.00'

PI Sta 12+50.65
 D = 819.02' (RT)
 L = 135.47'
 T = 67.85'
 R = 932.00'
 SE = 11.00'

PI Sta 11+20.93
 D = 56.00' (RT)
 L = 228.15'
 T = 66.26'
 R = 203.87'
 SE = 11.00'

PI Sta 11+20.93
 D = 56.00' (RT)
 L = 228.15'
 T = 66.26'
 R = 203.87'
 SE = 11.00'

PI Sta 11+20.93
 D = 56.00' (RT)
 L = 228.15'
 T = 66.26'
 R = 203.87'
 SE = 11.00'

PI Sta 11+20.93
 D = 56.00' (RT)
 L = 228.15'
 T = 66.26'
 R = 203.87'
 SE = 11.00'

PI Sta 11+20.93
 D = 56.00' (RT)
 L = 228.15'
 T = 66.26'
 R = 203.87'
 SE = 11.00'

PI Sta 11+20.93
 D = 56.00' (RT)
 L = 228.15'
 T = 66.26'
 R = 203.87'
 SE = 11.00'

PI Sta 11+20.93
 D = 56.00' (RT)
 L = 228.15'
 T = 66.26'
 R = 203.87'
 SE = 11.00'

PI Sta 11+20.93
 D = 56.00' (RT)
 L = 228.15'
 T = 66.26'
 R = 203.87'
 SE = 11.00'

PI Sta 11+20.93
 D = 56.00' (RT)
 L = 228.15'
 T = 66.26'
 R = 203.87'
 SE = 11.00'

PI Sta 11+20.93
 D = 56.00' (RT)
 L = 228.15'
 T = 66.26'
 R = 203.87'
 SE = 11.00'

PI Sta 11+20.93
 D = 56.00' (RT)
 L = 228.15'
 T = 66.26'
 R = 203.87'
 SE = 11.00'

PI Sta 11+20.93
 D = 56.00' (RT)
 L = 228.15'
 T = 66.26'
 R = 203.87'
 SE = 11.00'

Permit Drawing
 Sheet 7 of 15

23
 KEITH HAROLD HASTINGS
 PATRICK OMAR DOSSON

22
 SEE MITIGATION PLANS

21
 SEE MITIGATION PLANS

20
 SEE MITIGATION PLANS

19
 SEE MITIGATION PLANS

18
 SEE MITIGATION PLANS

17
 SEE MITIGATION PLANS

16
 SEE MITIGATION PLANS

15
 SEE MITIGATION PLANS

14
 SEE MITIGATION PLANS

13
 SEE MITIGATION PLANS

12
 SEE MITIGATION PLANS

11
 SEE MITIGATION PLANS

10
 SEE MITIGATION PLANS

9
 SEE MITIGATION PLANS

8
 SEE MITIGATION PLANS

7
 SEE MITIGATION PLANS

6
 SEE MITIGATION PLANS

5
 SEE MITIGATION PLANS

4
 SEE MITIGATION PLANS

3
 SEE MITIGATION PLANS

2
 SEE MITIGATION PLANS

1
 SEE MITIGATION PLANS

0
 SEE MITIGATION PLANS

-1
 SEE MITIGATION PLANS

-2
 SEE MITIGATION PLANS

-3
 SEE MITIGATION PLANS

-4
 SEE MITIGATION PLANS

-5
 SEE MITIGATION PLANS

-6
 SEE MITIGATION PLANS

-7
 SEE MITIGATION PLANS

-8
 SEE MITIGATION PLANS

-9
 SEE MITIGATION PLANS

-10
 SEE MITIGATION PLANS

-11
 SEE MITIGATION PLANS

-12
 SEE MITIGATION PLANS

-13
 SEE MITIGATION PLANS

-14
 SEE MITIGATION PLANS

-15
 SEE MITIGATION PLANS

-16
 SEE MITIGATION PLANS

-17
 SEE MITIGATION PLANS

-18
 SEE MITIGATION PLANS

-19
 SEE MITIGATION PLANS

-20
 SEE MITIGATION PLANS

-21
 SEE MITIGATION PLANS

-22
 SEE MITIGATION PLANS

-23
 SEE MITIGATION PLANS

-24
 SEE MITIGATION PLANS

-25
 SEE MITIGATION PLANS

-26
 SEE MITIGATION PLANS

-27
 SEE MITIGATION PLANS

-28
 SEE MITIGATION PLANS

-29
 SEE MITIGATION PLANS

-30
 SEE MITIGATION PLANS

-31
 SEE MITIGATION PLANS

-32
 SEE MITIGATION PLANS

-33
 SEE MITIGATION PLANS

34
 SEE MITIGATION PLANS

35
 SEE MITIGATION PLANS

36
 SEE MITIGATION PLANS

37
 SEE MITIGATION PLANS

38
 SEE MITIGATION PLANS

39
 SEE MITIGATION PLANS

40
 SEE MITIGATION PLANS

41
 SEE MITIGATION PLANS

42
 SEE MITIGATION PLANS

43
 SEE MITIGATION PLANS

44
 SEE MITIGATION PLANS

45
 SEE MITIGATION PLANS

46
 SEE MITIGATION PLANS

47
 SEE MITIGATION PLANS

48
 SEE MITIGATION PLANS

49
 SEE MITIGATION PLANS

50
 SEE MITIGATION PLANS

51
 SEE MITIGATION PLANS

52
 SEE MITIGATION PLANS

53
 SEE MITIGATION PLANS

54
 SEE MITIGATION PLANS

55
 SEE MITIGATION PLANS

56
 SEE MITIGATION PLANS

57
 SEE MITIGATION PLANS

58
 SEE MITIGATION PLANS

59
 SEE MITIGATION PLANS

60
 SEE MITIGATION PLANS

61
 SEE MITIGATION PLANS

62
 SEE MITIGATION PLANS

63
 SEE MITIGATION PLANS

64
 SEE MITIGATION PLANS

65
 SEE MITIGATION PLANS

66
 SEE MITIGATION PLANS

67
 SEE MITIGATION PLANS

68
 SEE MITIGATION PLANS

69
 SEE MITIGATION PLANS

70
 SEE MITIGATION PLANS

71
 SEE MITIGATION PLANS

72
 SEE MITIGATION PLANS

73
 SEE MITIGATION PLANS

74
 SEE MITIGATION PLANS

75
 SEE MITIGATION PLANS

76
 SEE MITIGATION PLANS

MATCH LINE - STA 79+00

MATCH LINE - STA 65+00

12/5/2012 1:55 PM C:\Users\psh\Documents\Drawings\12707.mxd psh.psh

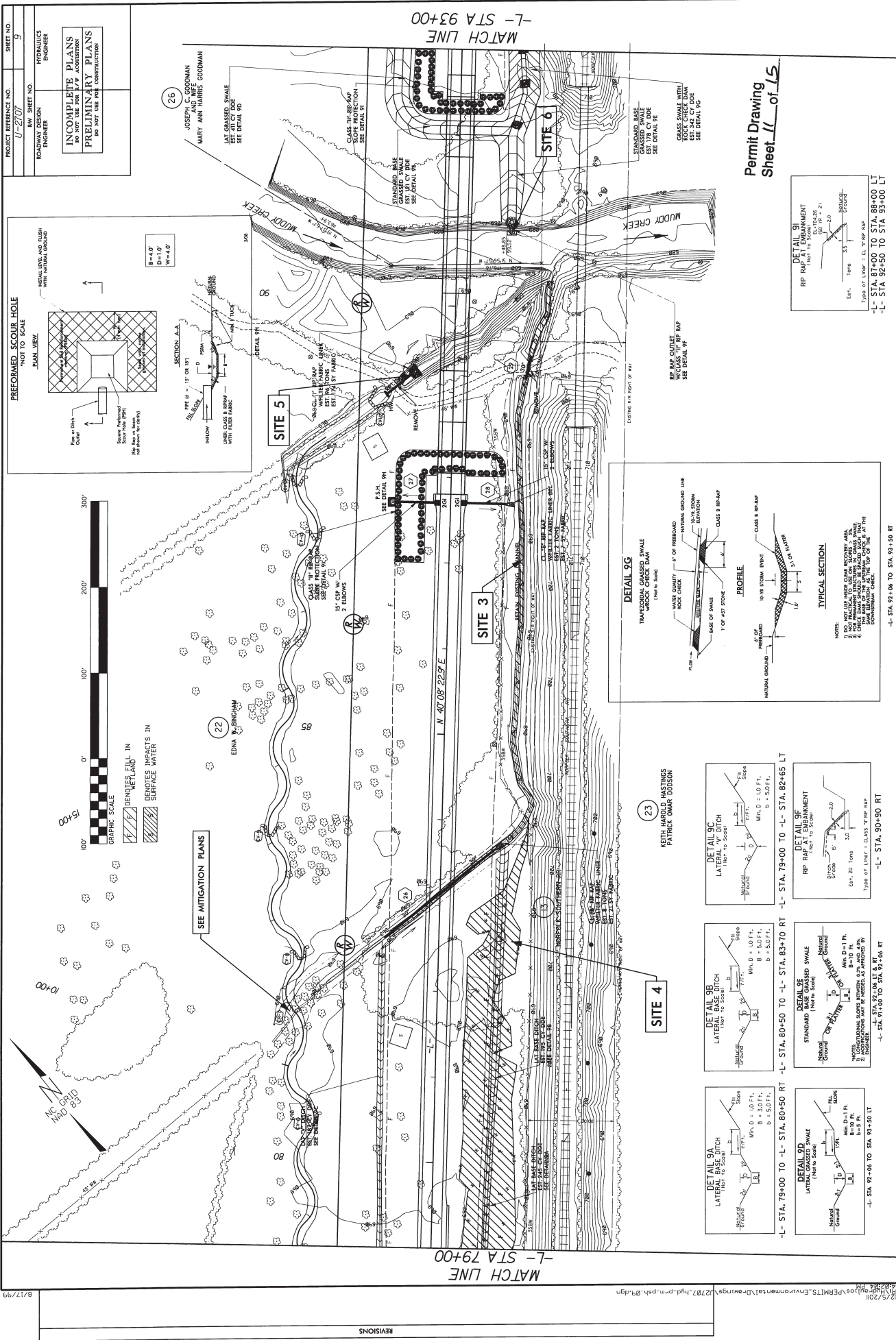

PROJECT REFERENCE NO.	U-2107	SHEET NO.	9
ROADWAY DESIGN ENGINEER	JOSEPH ANDERSON	HYDRAULICS ENGINEER	MARY ANN THERRS GOODMAN
<p>INCOMPLETE PLANS DO NOT USE FOR CONSTRUCTION</p> <p>PRELIMINARY PLANS FOR THE CONTRACTOR</p>			

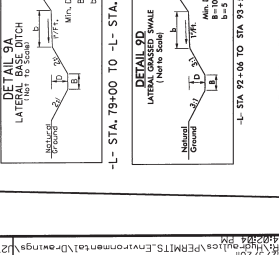
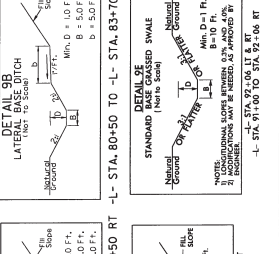
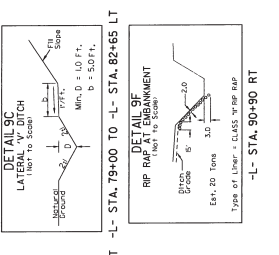
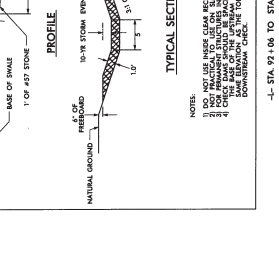
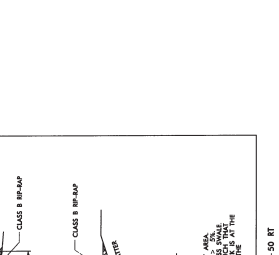
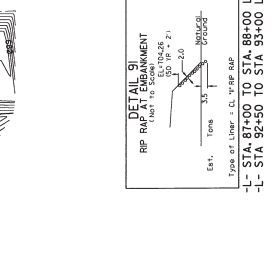
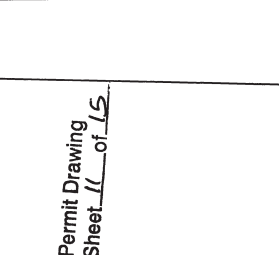
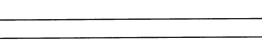
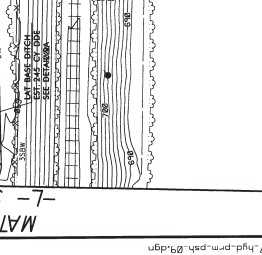
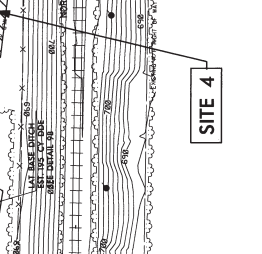
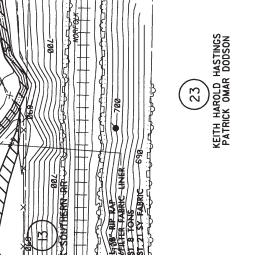
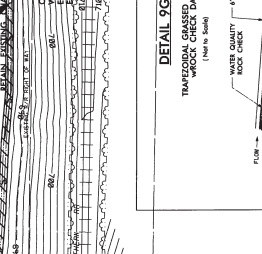
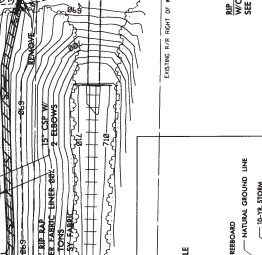
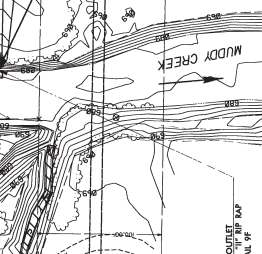
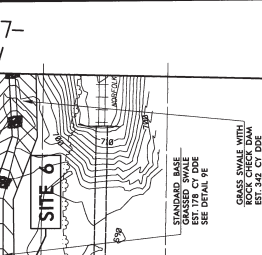
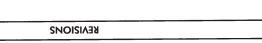
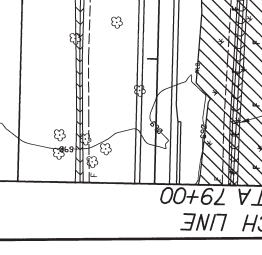
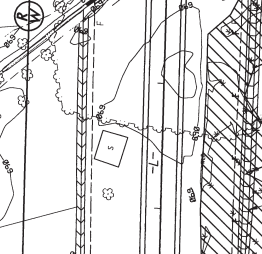
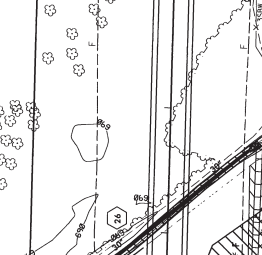
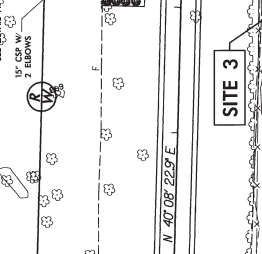
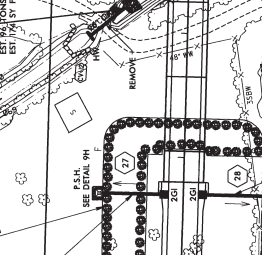
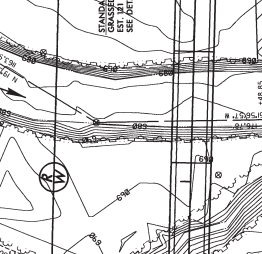
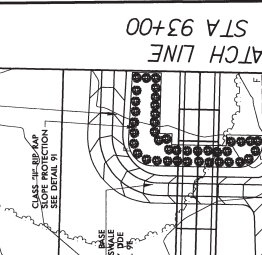
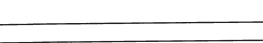
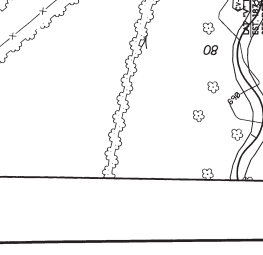
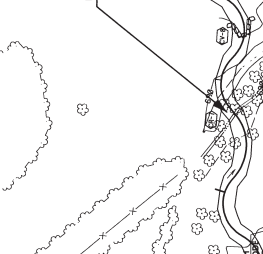
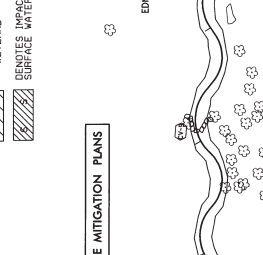
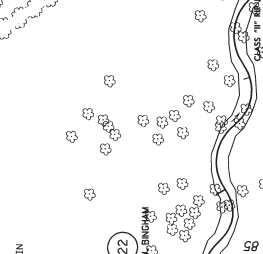
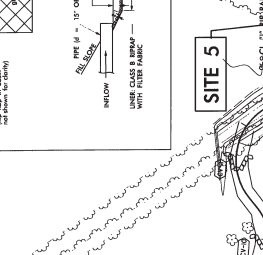
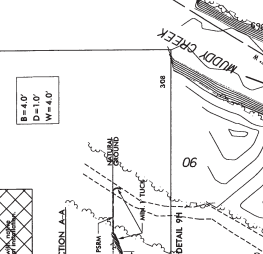
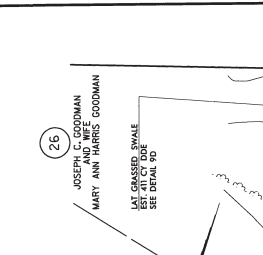
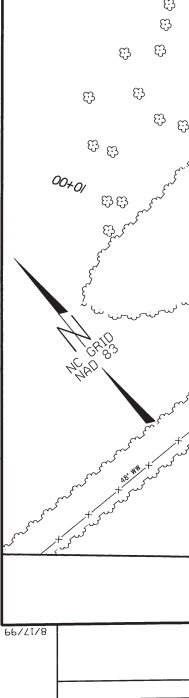
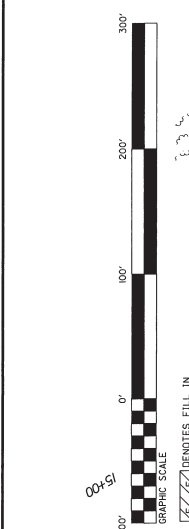
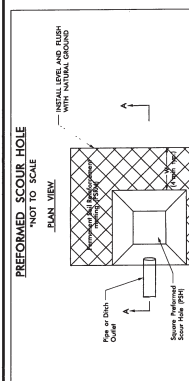

Permit Drawing
Sheet 11 of 15

26
JOSEPH ANDERSON
MARY ANN THERRS GOODMAN

23
KETH HAROLD HASTINGS
PATRICK OMAR DOSSON

23
KETH HAROLD HASTINGS
PATRICK OMAR DOSSON

23
KETH HAROLD HASTINGS
PATRICK OMAR DOSSON

23
KETH HAROLD HASTINGS
PATRICK OMAR DOSSON

23
KETH HAROLD HASTINGS
PATRICK OMAR DOSSON

23
KETH HAROLD HASTINGS
PATRICK OMAR DOSSON

23
KETH HAROLD HASTINGS
PATRICK OMAR DOSSON

23
KETH HAROLD HASTINGS
PATRICK OMAR DOSSON

23
KETH HAROLD HASTINGS
PATRICK OMAR DOSSON

MATCH LINE -L- STA 79+00

MATCH LINE -L- STA 93+00

REVISIONS

B/17/99

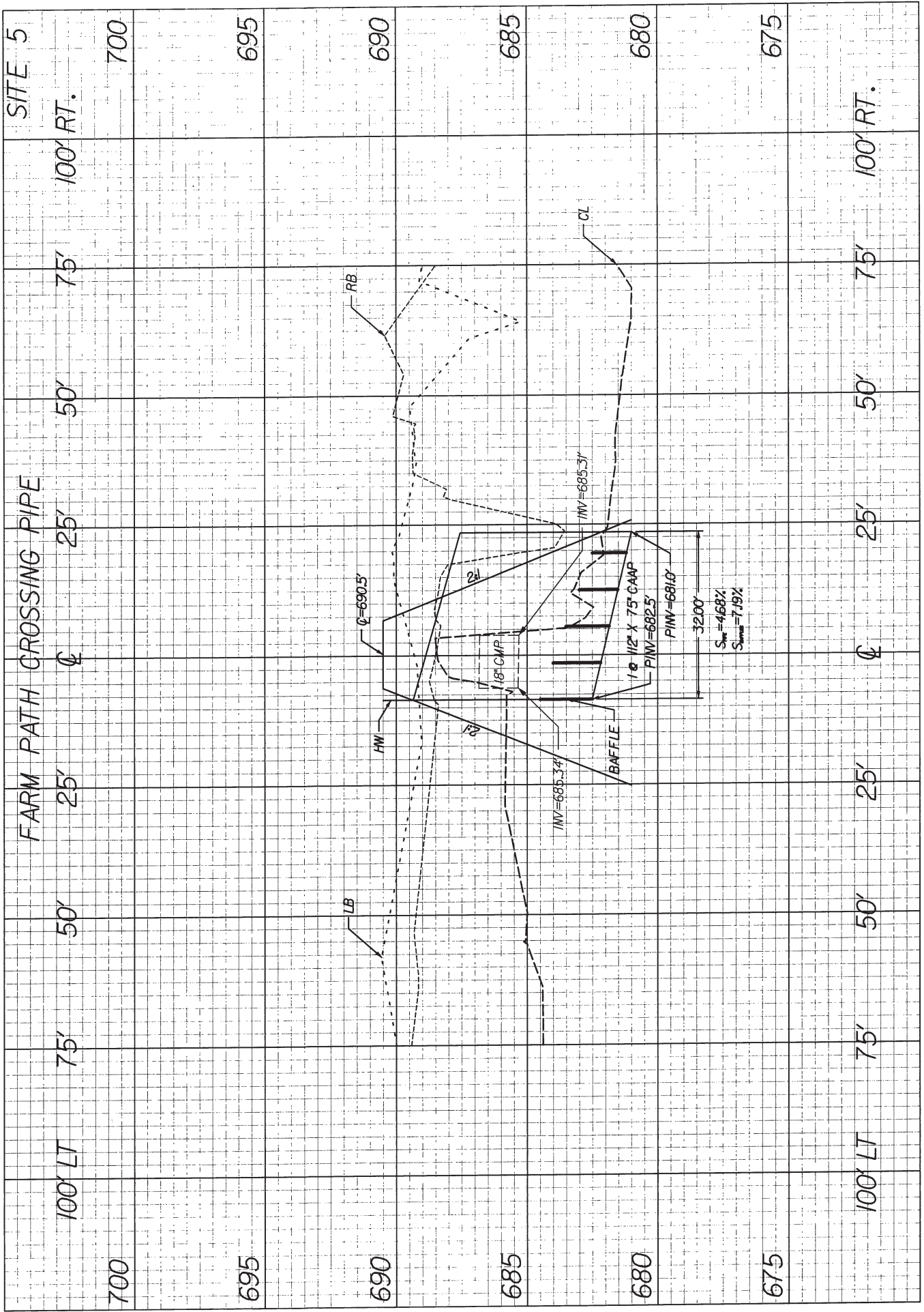



PROJECT REFERENCE NO. U-2107
ROADWAY DESIGN ENGINEER

SHEET NO. 16
HYDRAULICS ENGINEER

PRELIMINARY PLANS
DO NOT USE FOR CONSTRUCTION

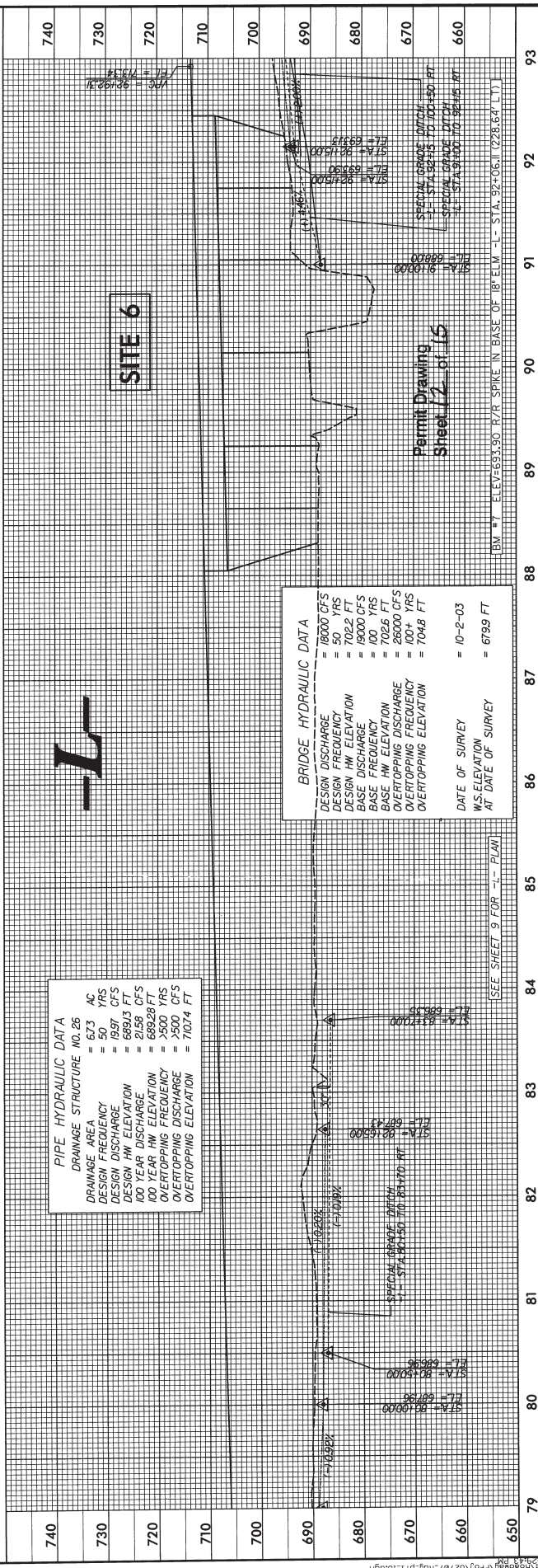
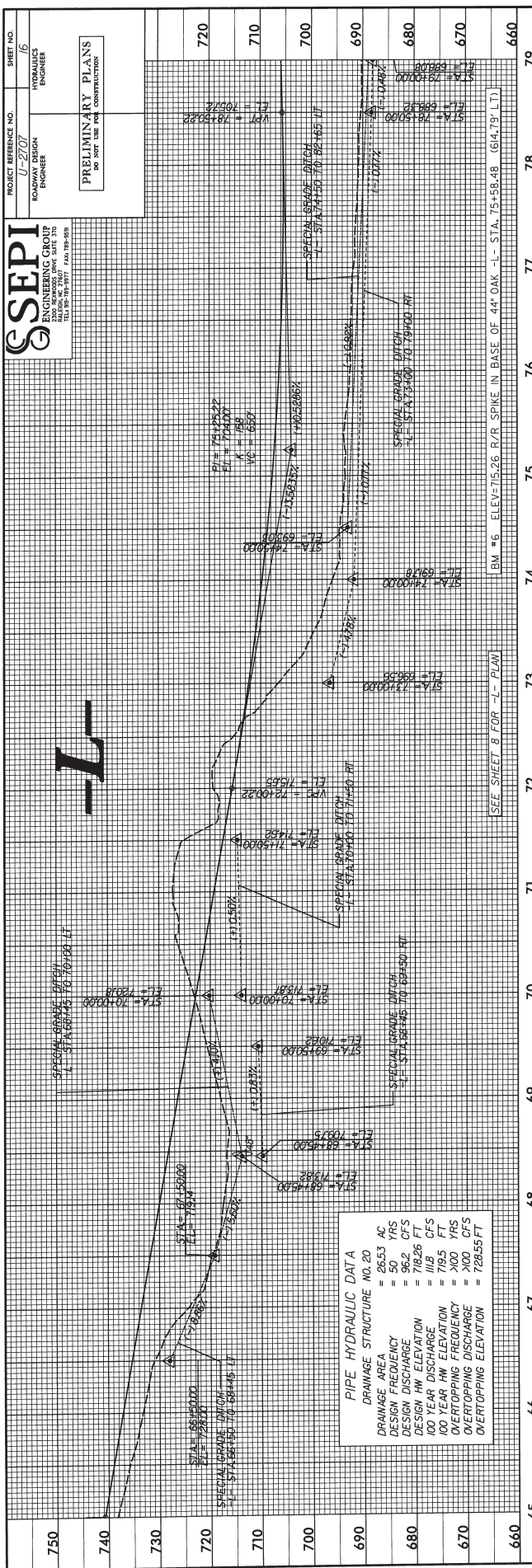

SITE 6

DESIGN DISCHARGE	= 18000 CFS
DESIGN FREQUENCY	= 50 YRS
DESIGN HW ELEVATION	= 702.2 FT
BASE DISCHARGE	= 19000 CFS
BASE FREQUENCY	= 100 YRS
BASE HW ELEVATION	= 702.6 FT
OVERTOPPING DISCHARGE	= 26000 CFS
OVERTOPPING FREQUENCY	= 300 YRS
OVERTOPPING ELEVATION	= 704.6 FT
DATE OF SURVEY	= 10-2-03
WS ELEVATION AT DATE OF SURVEY	= 679.9 FT

Permit Drawing
Sheet 12 of 15



TOPO MAP

SCALE: 1" = 2000'

NCDOT
DIVISION OF HIGHWAYS
FORSYTH COUNTY
PROJECT: U-2707

SR 3000 (IDOLS ROAD), FROM
SR 2999 (HAMPTON ROAD)
TO US 158 (CLEMMONS ROAD)

PROPERTY OWNERS

NAMES AND ADDRESSES

REFERENCE NO.	NAMES	ADDRESSES
20-A	LENTZ PROPERTY MANAGEMENT, LLC	PO BOX 989 CLEMMONS, NC 27012
22	EDNA BINGHAM	PO BOX 5 CLEMMONS, NC 27012
13	NORFOLK SOUTHERN RR	THREE COMMERCIAL PLACE NORFOLK, VA 23510
26	JOSEPH C. GOODMAN MARY ANN HARRIS GOODMAN	3049 S. STRATFORD ROAD WINSTON SALEM, NC 27103

NCDOT

DIVISION OF HIGHWAYS

FORSYTH COUNTY

PROJECT: U-2707

**SR 3000 (IDOLS ROAD), FROM
SR 2999 (HAMPTON ROAD)
TO US 158 (CLEMMONS ROAD)**

WETLAND PERMIT IMPACT SUMMARY															
Site No.	Station (From/To)	Structure Size / Type	WETLAND IMPACTS				SURFACE WATER IMPACTS								
			Permanent Fill In Wetlands (ac)	Temp. Fill In Wetlands (ac)	Excavation in Wetlands (ac)	Mechanized Clearing in Wetlands (ac)	Hand Clearing in Wetlands (ac)	Permanent SW impacts (ac)	Temp. SW impacts (ac)	Existing Channel Impacts Permanent (ft)	Existing Channel Impacts Temp. (ft)	Natural Stream Design (ft)			
1	-L- 40+80	48"			0.03										
2	-L- 68+50	48"													
3	-L- 73+09 to 90+31	Roadway Fill													
4	-L- 75+98 to 84.02 Rt	Roadway Fill	0.78												
5*	-L- 89.00 Lt	1@96" CAAP													
6	-L- 90+85 Rt	Bank Stabilization													
TOTALS:			0.78		0.03										

* The proposed 96" CAAP is considered an enhancement due to the reconnection of the fish passage and hydrology, therefore no impacts will be calculated here.

NC DEPARTMENT OF TRANSPORTATION
DIVISION OF HIGHWAYS

FORSYTH COUNTY
WBS - 34845.1.1 (U-2707)

SHEET 15 of 15 12/07/11

U-2707 STREAM
MITIGATION PLAN

FORSYTH COUNTY, NORTH CAROLINA



NORTH CAROLINA
DEPARTMENT OF TRANSPORTATION



DECEMBER 22, 2011

**U-2707 Stream
Mitigation Plan**

Forsyth County, North Carolina

December 5, 2011

**Prepared For:
North Carolina Department of Transportation**



Report Prepared by Mulkey, Inc.:

**Emmett Perdue, P.E.
Design Engineer – Natural Resources**

**Wendee Smith
Project Manager – Natural Resources Group Manager**

Table of Contents

1.0 BASELINE INFORMATION	1
1.1 Introduction.....	1
1.2 General Watershed Information.....	1
1.3 Project Site Description.....	1
1.3.1 Topography, Physiographic Providence, and Soils.....	1
1.3.2 Jurisdictional Wetlands.....	2
1.3.3 Existing Plant Communities.....	2
1.3.4 Threatened and Endangered Species.....	2
2.0 SITE SELECTION	3
2.1 Reach 1 (R1) Existing Conditions.....	3
2.2 Reach 2 (R2) Existing Conditions.....	5
3.0 SITE PROTECTION INSTRUMENT	5
4.0 OBJECTIVES	6
5.0 MITIGATION WORK PLAN	6
5.1 Natural Channel Design.....	6
5.1.1 Introduction.....	6
5.1.2 Reference Reach Analyses.....	6
5.1.3 Sediment Transport Analysis.....	7
5.1.4 Flood Analysis.....	8
5.1.5 Proposed Design Reach 1 (R1).....	8
5.1.6 Proposed Design Reach 2 (R2).....	9
5.1.7 Stream Riparian Planting Plan.....	10
5.2 Construction Implementation.....	11
6.0 PERFORMANCE STANDARDS	11
7.0 MONITORING REQUIREMENTS	11
8.0 OTHER INFORMATION	12
9.0 DETERMINATION OF CREDITS	12
9.1 Credit Release Schedule.....	12
10.0 GEOGRAPHIC SERVICE AREA	12
11.0 MAINTENANCE PLAN	13
12.0 LONG TERM MANAGEMENT PLAN	13
13.0 FINANCIAL ASSURANCES	13

Table of Contents (cont.)

List of Figures

- Figure 1. Vicinity Map
- Figure 2. Drainage Area Map
- Figure 3. Reference Reach Vicinity Map – Spencer Creek
- Figure 4. FEMA Flood Map

Appendices

- Appendix A Profiles & Cross Sections
- Appendix B Particle Size Distribution
- Appendix C Entrainment Calculations
- Appendix D Velocity Calculations
- Appendix E Design Cross Sections
- Appendix F Morphological Tables
- Appendix G Pipe Calculations
- Appendix H Typical & Details
- Appendix I Plan & Profile

U-2707 STREAM MITIGATION PLAN

FORSYTH COUNTY

WBS NO.: 34845.1.1

DECEMBER 22, 2011

1.0 BASELINE INFORMATION

1.1 Introduction

This U-2707 stream mitigation plan proposes improvements to be implemented by the North Carolina Department of Transportation (NCDOT) along two unnamed tributaries (UT's) to Muddy Creek. The plan is being completed to provide on-site mitigation for unavoidable stream impacts associated with the construction of Transportation Improvement Project (TIP) number U-2707, or the Idols Road Extension (SR 3000) in Forsyth County, North Carolina near the town of Clemmons. The project location is within the floodplain of Muddy Creek and consists of approximately 1,800 linear feet of restoration along Reach 1 (R1) coupled with the enhancement of bank conditions and reconnection of hydrology associated with the replacement of a culvert along Reach 2 (R2) (Figure 1).

1.2 General Watershed Information

The two unnamed tributaries are situated within the Yadkin-Pee Dee River Basin within the US Geological Survey (USGS) hydrological unit code (HUC) 03040101 and the NC Division of Water Quality (NCDWQ) sub-basin 03-07-04. R1 has an existing drainage area of 0.42 square miles (271 acres) at the culvert under Clouds Harbor Trail, the upstream limit of the project, increasing to 0.49 square miles (316 acres) at the point where the road alignment will fill the stream. R2 has an existing drainage area of 0.62 square miles (410 acres) at the culvert inlet. Both of these drainage areas are predominantly woodland/pasture areas with residential and commercial intermixed.

1.3 Project Site Description

1.3.1 Topography, Physiographic Providence, and Soils

The project site is situated entirely within the southwest portion of the Muddy Creek floodplain. A railway embankment and the future SR 3000 (Idols Road) form the southeastern boundary of the project site. The floodplain of Muddy Creek is relatively flat with minimal elevation change. There is a large levee on the western bank of Muddy Creek that separates it from R2. Elevation ranges on the project site from 700 feet above mean sea level (msl) along Clouds Harbor Trail to 679 feet msl at the confluence with Muddy Creek. The U-2707 mitigation site is within the Piedmont physiographic province; specifically, the Southern Outer Piedmont Ecoregion (Griffith et al., 2002). According to the Forsyth County Soil Survey, Chewacla soils dominate the project area.

1.3.2 Jurisdictional Wetlands

Jurisdictional wetland determinations were performed using the three-parameter approach as prescribed in the 1987 *Corps of Engineers Wetlands Delineation Manual* (Environmental Laboratory, 1987). NCDOT personnel performed wetland delineations between December 1998 and November 2001 and reconfirmed any changes in June 2011. Four small wetlands occur within the entire U-2707 project area. Three of these areas were found to be non-jurisdictional due to a lack of hydric soils and are not within the work limits of the mitigation site. The fourth is contained within the stream banks of R1 approximately 165 feet downstream of Clouds Harbor Trail. This fourth wetland was deemed to be unimportant and non-mitigable because it was created by horses accessing the stream. The banks in this location are severely degraded and almost nonexistent therefore creating an inline channel pool/wetland area (NCDOT, 2002).

1.3.3 Existing Plant Communities

The vegetative communities found within the project area can be characterized by two major groupings. These groupings include pastureland (predominantly fescue) and the riparian fringe. The riparian fringe is a narrow band of vegetation found along each unnamed tributary. Common herbaceous species found include poison ivy (*Toxicodendron radicans*), jewelweed (*Impatiens capensis*), common violet (*Viola* sp.), common greenbrier (*Smilax roundifolia*), Japanese honeysuckle (*Lonicera japonica*), multiflora rose (*Rosa multiflora*), and giant cane (*Arundinaria gigantea*). Woody species located in the subcanopy primarily consist of silky dogwood (*Cornus amomum*), Chinese privet (*Ligustrum sinense*), river birch (*Betula nigra*), black willow (*Salix nigra*), and black cherry (*Prunus serotina*). Common tree species occupying the canopy of the riparian fringe include boxelder (*Acer negundo*), green ash (*Fraxinus pennsylvanica*), and tulip poplar (*Liriodendron tulipifera*).

1.3.4 Threatened and Endangered Species

According to the US Fish and Wildlife Service (USFWS), two endangered and one threatened species are known to occur in Forsyth County. The threatened species (bog turtle) is listed by similarity of appearance (S/A), but is neither biologically threatened nor endangered. Therefore, the bog turtle is not subject to Section 7 consultation (Endangered Species Act). Information regarding these federally listed species can be found in Table 1.

Table 1. Federally Listed Species for Forsyth County

Common Name	Scientific Name	Federal Status	Preferred Habitat	Habitat Availability	Biological Conclusion
Red-cockaded woodpecker	<i>Picoides borealis</i>	Endangered	Open park-like pine stands (live) w/ little undergrowth	No	No Effect
Small-anthered bittercress	<i>Cardamine microanthera</i>	Endangered ^A	Near seeps and wet rock crevices, moist woods near small streams, full to partial sun	No	No Effect
Bog Turtle	<i>Clemmys muhlenbergii</i>	Threatened (S.A) ^B	Shallow spring-fed fens, open and sunny muddy-bottomed streams	No	Not Applicable

^A Denotes no specimen from Forsyth County found in the past twenty years.

^B Threatened due to similarity of appearance (S/A) denotes a species that is threatened due to similarity of appearance with other rare species and is listed for its protection. These species are not biologically endangered or threatened and are not subject to Section 7 consultation.

2.0 SITE SELECTION

Both R1 and R2 were selected because of their proximity to the impact that they will offset and due to their degraded condition. As a part of the U-2707 right-of-way, these unnamed tributaries are part of the system being impacted by the construction of the Idols Road Extension. After analyzing all the impacted systems affected by the U-2707 project, R1 and R2 were identified as highly degraded systems offering the most potential ecological uplift. Therefore, the proximity to the impact being offset and the degraded nature of the streams offer an exemplary mitigation site.

2.1 Reach 1 (R1) Existing Conditions

The headwaters of R1 originate in a residential neighborhood approximately 0.3 miles south of the intersection of existing SR 3000 (Hampton Road) and US 158. The tributary flows in a southerly direction for approximately 0.3 miles before turning to the east/northeast and eventually connecting with R2 just upstream of Muddy Creek. The drainage area associated with R1 is 316 acres (0.49 mi²) and is predominantly woodland/pasture with residential intermixed (Figure 2). The current location of the R1 stream channel (along the northeast toe of the Norfolk Southern railroad embankment) is a product of agricultural operations and railroad construction. Agriculture practices over the last century have played a major role in the destabilization of R1 by relocating, straightening, and channelizing the stream to provide for more active and accessible pastureland. In addition, vegetation removal throughout what should be the riparian buffer coupled with livestock access to the stream for watering purposes have created unstable banks contributing more sediment to the system. In addition to bank instability, Muddy Creek being actively dredged has increased the rate at which lower sections of R1 have become incised and entrenched. To combat this incision and the instability along the railroad, large boulders and concrete have been placed throughout the downstream section effectively removing any aquatic passage or hydrologic connection to Muddy Creek.

The vertical longitudinal profile of R1 indicates an altered system with fluctuating boundary conditions that is on the border of instability. Currently, the existing R1 channel flows approximately 2,000 linear feet within the limits of the U-2707 project area. The existing channel slope averages 0.00632 ft/ft over a representative 1100 feet of channel which is characteristic of E and C channels typical for this valley type. However, the upper 300 feet of the reach is characterized by a flat bed slope while the banks and bankfull channel are holding the average bankfull slope. This section of channel is actively being accessed by livestock and therefore the bed is being compressed into a uniform condition. The channel has also been straightened and channelized which is visible in the plan view of the channel and through the levees on both sides of the channel in cross sections 1 and 2. From station 300 to 600, the channel is not actively being accessed by livestock and maintains the best riparian buffer. This section of channel is the most stable with minimal incision occurring and consistent slope features across the banks, bankfull, water surface and bed. The lower 500 feet (station 600 to 1100), however, show the beginnings of incision as the channel bed deepens relative to the banks. This can be attributed to a downstream head cut moving through the channel as a result of the active dredging occurring in Muddy Creek. This corresponds to cross section 5 having a deep, narrow channel bottom as is the case with C streams moving towards G streams. These three scenarios depict a stream with instability on the upper and lower ends and altering

boundary conditions throughout. The tendency for streams in this situation is for the upper and lower conditions to migrate through the center and alter the channel conditions until equilibrium is reached. The complete data set for the existing profile information for R1 is presented in Appendix A.

Table 2. Summary of Existing Cross Sections –Reach 1 (R1)

Cross Section	Station No.	Morph. Feature	BKF Area (ft ²)	BKF Width (ft)	BKF Max Depth (ft)	W/D Ratio*	Ent. Ratio*	LBH Ratio*	Stream Class.*
1	88.5	Riffle	9.86	11.58	1.63	13.62	10.05	1.54	C5
2	136.5	Pool	18.73	14.22	2.47	10.77	9.46	--	--
3	465.5	Riffle	8.93	13.66	1.68	21.02	13.18	1.31	C5
4	538	Pool	16.55	17.87	2.08	19.22	8.95	--	--
5	1115	Riffle	14.00	8.86	2.37	5.61	14.66	1.33	E5
6	N/A	Riffle	13.35	14.82	1.41	16.47	3.29	1.73	C5

*Notes: Ent. Ratio is "Enrichment Ratio"

W/D Ratio is "Width/Depth Ratio"

LB Ratio is "Low Bank Height Ratio"

Stream classification is only viable along riffle sections.

The cross section data is summarized in Table 2 above but graphs and the associated data can also be found in Appendix A. The cross section data suggests R1 is a stable C5 channel based on the Rosgen stream classification system (Rosgen, 1994). However, upon closer inspection of the riffle cross section graphs (pool cross sections are not used for evaluation), three trends toward instability can be spotted. The first, typical of most stream channels and not an indication of instability alone, is the bankfull area and width are both generally increasing as the riffle cross sections move downstream. The second is the degree of incision (Low Bank Height Ratio) remains consistent until cross section 6, where it increases slightly. And the third is the entrenchment ratio remains above 10 until the last cross section where it drops significantly to 3.29. These trends together indicate channel conditions that result in the floodplain being removed from the bankfull elevation as the bankfull elevation sinks lower into the stream channel on the downstream end. This situation is indicative of altered boundary conditions creating head cuts which travel upstream creating instability by producing steep, denuded, undercut banks; excessive in channel velocities; and overly widened channels.

A reach-wide modified Wolman Pebble Count was conducted to determine the average d_{50} (50% of the sampled population is equal to or finer than the representative particle diameter) to be approximately 0.13 mm for R1, which falls into the very fine sand size category. The wetted perimeter d_{50} was approximately 2.5mm. The bar sample was predominantly sand and therefore the d_{50} could not be determined. The particle size distribution data is presented in Appendix B. The results of the data suggest R1 is a sand dominated system with little grade control evidenced by the absence of a true pavement/subpavement stratum. These types of systems have a sensitive response to the alteration of boundary conditions since the channel is not well armored. Therefore these systems depend highly on bank vegetation and channel dimension, pattern and profile to maintain equilibrium.

The vertical longitudinal profile, corresponding cross sections, and material substrate of R1 exhibit conditions in which the channel is on the beginning path of instability. Taking into

account the typical stream types for this valley and the existing condition data, R1 is moving from a C to a Gc on a stream successional path of E→C→Gc→F→C→E (See Diagram 1 below). If allowed to fully develop, the channel's instability will lead to increased sediment supply through the mass wasting of banks, vertical instability, and channel widening.

Diagram 1. Stream Channel Succession

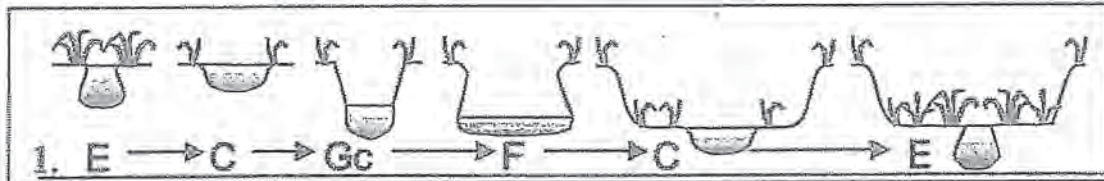

2.2 Reach 2 (R2) Existing Conditions

The R2 stream channel originates just north of the intersection of SR 3000 and US 158 and flows in an easterly direction for approximately 1.0 mile before turning south. R2 then flows south across the Muddy Creek floodplain for approximately 0.5 mile and eventually confluences with R1 just upstream of Muddy Creek. The existing drainage area associated with R2 is 0.64 square mile (410 acres.). R2 contains approximately 400 linear feet of existing channel within the project area and classifies as a G5 stream type. The average slope of this channel is 0.0023 ft/ft which is typical for streams in this valley type. The stream channel and banks associated with this tributary have been principally altered through channelization evidenced by the linear characteristics in the plan view (Figure 1 and 2). The stream section below the culvert has also seen increased entrenchment due to the dredging of Muddy Creek.

Agricultural access through the installation of a farm path and the associated stream crossing has exacerbated the degradation in R2. A high level analysis of R2 was not conducted because the farm path culvert was identified as the major obstacle inhibiting aquatic passage. R2 displays signs of stability upstream of the farm path culvert; however immediately downstream of the culvert the stream is severely entrenched and incised. Erosion around the culvert is causing the path to collapse into the stream channel. The severity in elevation drop from the inlet to the outlet of the culvert does not allow fish passage and minimizes any hydrologic connection of the upper part of R2 to Muddy Creek.

3.0 SITE PROTECTION INSTRUMENT

The Site will be located within the NCDOT right-of-way for the project and designated on the plan sheets as a mitigation area. The Site will be managed to prohibit all use inconsistent with its use as mitigation, including any activity that would materially alter the biological integrity or functional and educational value of the site, consistent with the mitigation plan. The Site will be recorded on the NEU mitigation geo-database (MGD). The MGD is distributed to the Divisions to designate the location and protected status of all onsite mitigation. After closeout, the Site will be placed in the NCDOT Stewardship Program for long term management and protection.

The Site will be managed according to the terms of this mitigation plan and the NCDOT Stewardship Process.

4.0 OBJECTIVES

The goal of the project is to improve water quality, to reduce bank erosion, to reestablish a floodplain along R1, and to improve the aquatic and terrestrial wildlife habitat. The functional restoration of the site will occur through a mixture of various treatments consistent with natural channel design techniques for 1800 linear feet of R1 and 153 linear feet of R2. Along R1, these techniques will include removing livestock from the stream through the implementation of a conservation easement; establishing a floodplain or reconnecting the stream back to its historic floodplain; increasing the amount of aquatic habitat through the addition of rock and wood structures; and reestablishing native plant communities throughout the conservation easement, whereby reintroducing shading, cover areas, and travel corridors. The restoration of R2 will be limited to the replacement of the existing culvert with a new arched pipe with baffles to allow functional fish passage, establish grade control, and minimize velocities therefore providing a more stable stream system.

5.0 MITIGATION WORK PLAN

The mitigation work plan will consist of construction activities associated with the implementation of the natural channel design set forth below.

5.1 Natural Channel Design

Natural channel design is the principle developed by Dave Rosgen of using stable reference reach streams to develop and project dimensionless variables onto unstable reaches with similar boundary conditions in order to superimpose a new stable system in low quality environments. The following section outlines the parameters necessary to undertake natural channel design and describes the fully developed mitigation plan.

5.1.1 Introduction

Based on existing condition data, the restoration of the U-2707 project was broken into two reaches, Reach 1 (R1) and Reach 2 (R2). R1 will undergo the most extensive restoration via priority I and II restoration techniques. Due to the nature of the valley and changing channel characteristics, explained further below, R1 was further divided into R1a (upstream 920ft) and R1b (downstream 880ft). R2 restoration is comprised of the removal and replacement of a nonfunctioning culvert and therefore some of the following analysis does not apply.

5.1.2 Reference Reach Analyses

One reference reach has been identified for use on the U-2707 stream restoration site. Spencer Creek was chosen as it represents a stable, rural, piedmont stream type and shares the same watershed size and characteristics as the project stream.

Spencer Creek is situated in Montgomery County, approximately 8.0 miles from Troy along the west side of SR 1134 (Figure 3). Spencer Creek is characterized as a second order stream and classifies as a rural E4/C4 stream type. Specific morphological data for this reference reach are given within the morphological table found in Appendix B. Its watershed is approximately 0.55 square mile (355 acres) and encompasses large tracts of undeveloped woodland within the Uwharrie National Forest. Common riparian species found along this stream corridor include

American holly (*Ilex opaca*), red maple (*Acer rubrum*), sweet gum (*Liquidambar styraciflua*), mountain laurel (*Kalmia latifolia*), flowering dogwood (*Cornus florida*), water oak (*Quercus nigra*), willow oak (*Quercus phellos*), sourwood (*Oxydendrum arboreum*), and giant cane.

5.1.3 Sediment Transport Analysis

Sediment plays a major role in the influence of channel stability and morphology (Rosgen, 1996). A stable stream has the capacity to move its sediment load without aggrading or degrading.

The critical dimensionless shear stress (τ^*_{ci}) is the measure of force required to initiate general movement of particles in a bed of a given composition. Based on the d_i of 2.7 mm obtained from the active riffle sampling at cross section 3 and using a value of 0.1 mm for the bar sample d_{50} due to the composition of sand for R1, the critical dimensionless shear stress was calculated to be approximately 0.019 lbs/ft². Evaluating R1a and R1b with a consistent bankfull slopes, the differing channel geometries provide different bankfull shear stresses. R1a being classified a C5 channel has a smaller bankfull cross sectional area, but the geometry has a wider bankfull width and shallower depth resulting in a bankfull shear stress of 0.225 lbs/ft². R1b being classified an E5 channel has a larger bankfull area, but the smaller width and greater depth creates an environment where velocities are extremely high resulting in higher bankfull shear stress of 0.496 lbs/ft². These shear stresses result in the entrainment of particles a minimum of 16 mm in R1a and 38 mm in R1b. Entrainment and velocity calculation sheets used for this analysis are presented in Appendices C and D, respectively.

The bankfull shear stress for the proposed channel has to be sufficient to move the D_{84} of the bed material. The largest D_{84} particle determined within active riffles across the site was 4.87mm. Based on the entrainment calculations for the proposed R1a and R1b, the calculated bankfull shear stresses of 0.403 lbs/ft² and 0.284 lbs/ft² would move particles of 30 mm and 21 mm respectively. The proposed design provides the correct C5 channel geometry for both R1a and R1b, as seen in the design cross section overlays in Appendix E. However, due to valley conditions, R1a has an increased slope of 0.0080 ft/ft. This increase in slope increases velocities through the system with the same relative bankfull area and geometry which in turn creates a higher shear stress. Being further downstream and to match the existing conditions, R1b has a slightly larger bankfull cross sectional area than R1a but still retains the C5 channel geometry. This change in geometry coupled with the flattening of the slope through this section due to valley conditions allows the velocities and bankfull shear stress to be greatly reduced when compared to the existing conditions.

This analysis proves the system contains more than adequate bankfull shear stress to move the sediment through the system and raises concerns about degradation. The expected bankfull shear stress would move particles ranging from 21 mm to 30 mm. The largest particle found on depositional bars was 6 mm, while the D_{84} and D_{100} of the reach wide sampling of R1 was determined to be 8 mm and 32 mm, respectively. Therefore, the proposed design has sufficient shear stress to move the bedload associated with the project reach. However it will be extremely important that vegetation, grade control structures, and design plan form tolerances are strictly adhered to in construction as these will assist in maintaining the long term stability of the proposed channel, in particular in R1a.

5.1.4 Flood Analyses

The entire U-2707 mitigation site, including the channel of Muddy Creek and its immediate floodplain are located within the Federal Emergency Management Association's (FEMA) 100-year flood boundary, as depicted on Figure 4 (FEMA, 1991). These areas are inundated by the 100-year flood of Muddy Creek, where Base Flood Elevations (BFE) have been determined and a floodway established. However, the flood mapping only pertains to Muddy Creek proper. The unnamed tributaries are not a part of the flood study and are inundated by the floodwaters of Muddy Creek.

5.1.5 Proposed Design Reach 1 (R1)

The restoration of R1 has been divided into two sections, R1a and R1b, for design purposes. R1a, the upstream portion of R1 from Station 0+00 to 9+20, is characterized by a steeper valley slope and smaller bankfull channel. This area has been severely impacted by the agricultural practices of channelization and through livestock access. The stream channel has been straightened and deepened in locations while the banks have consistent levees on both sides of the channel except for where livestock is actively accessing the stream as a water supply. In the current condition, the channel classifies as a C5 stream, however as mentioned in Section 2 above, the system appears to be trending through the E→C→Gc→F→C→E stream succession. Therefore the design approach for R1a is to halt the succession at the first stage, E→C, through the design of a stable C channel; then reverse the trend, effectively jumping to the C→E stage, through the implementation of a vigorous vegetation plan.

R1a, being in the upstream steep valley scenario, will undergo Priority I restoration. This consists of raising the bed elevation such that the corresponding bankfull elevation matches the natural ground of the historic floodplain. In the case of R1a, performing this while keeping within the design ranges of the horizontal plan form variables of sinuosity, meander length, belt width, pool to pool spacing, and radius of curvature, the resulting bankfull slope was 0.0080 ft/ft (See Appendix F). The bankfull cross section was designed based on a cross sectional area of 10.0 ft² which matches the existing conditions and the NC Piedmont Regional Curve Data for a drainage area of 0.46 mi². The channel was then shaped based on a stable C5 dimension with a width to depth ratio of 14.4. This results in a bankfull width of 12.0 feet and a maximum bankfull depth of 1.37 feet. As depicted in the design overlays of cross section 1 and 3 in Appendix E, this geometry closely matches the existing conditions geometry at the bankfull stage therefore indicating a correct sizing. With the design of a stable C5 channel, the implementation of structures will provide vertical stability. Then a vigorous planting of the stream banks will facilitate bank stabilization and encourage a tightening of the bankfull width through sedimentation to form a stable E channel. This process will stabilize the system without moving through the complete E→C→Gc→F→C→E stream succession minimizing mass wasting of banks and down cutting of the channel.

R1b, the downstream section of R1, is characterized by a flatter valley slope, larger bankfull area and has the downstream elevation boundary condition at the confluence with R2. This channel encompasses the 863 feet of R1 being relocated due to the construction of SR3000. The current channel condition has been impacted by channelization and the creation of levees, but has also experienced inappropriate stabilization techniques along the section that abuts the railroad

alignment. In this area, concrete and large boulders have been introduced to the stream channel as vertical grade control. However, this technique has removed any hydrologic or aquatic connection to Muddy Creek by hardening large drops throughout the lower 300 feet. The disconnection to Muddy Creek coupled with the constraints imposed by the construction of SR3000 required R1b to be diverted to connect with R2 prior to connecting with Muddy Creek. This diversion resulted in a net loss of 185 linear feet of channel along R1 as R2 now makes the 185 foot connection to Muddy Creek.

Given the downstream elevation constraint imposed by the confluence with R2, R1b will undergo Priority II restoration. This type of restoration involves allowing the channel to drop through the natural valley ground level in an effort to meet other constraints. However, to ensure proper stability and flood capacity, a bankfull bench is excavated at the bankfull elevation to create the necessary floodplain. To achieve the required floodplain for a C5 channel, the entrenchment ratio (ratio of floodprone width to bankfull width) has to be greater than 2.2. Based on the NC Piedmont Regional Curve Data for a drainage area of 0.49 mi², the appropriate bankfull cross sectional area is 15.0 ft². Using a width to depth ratio of 13.0 provided a bankfull width of 14.0 feet and a maximum depth of 1.6 feet. Similar to R1a, design overlays of cross sections 5 and 6 in Appendix E confirm this geometry is suitable in comparison to the bankfull stage associated with the existing conditions. Using the entrenchment ratio of 2.2 and a bankfull width of 14.0 feet, the minimum floodprone width was calculated to be 30.8 feet. The design incorporates a 35.0 feet floodprone width to ensure this minimum is achieved. Adhering to the design variable ranges associated with sinuosity, meander length, belt width, pool to pool spacing, and radius of curvature (See Appendix F) while meeting the elevation constraints imposed by connecting R1a to R2; the design bankfull slope for R1b was determined to be 0.0044 ft/ft. These channel modifications in slope and geometry significantly lower the shear stress and velocities in this section creating a more stable system. As with R1a, the implementation of structures for grade control and vegetation for bank stability and channel tightening will significantly improve the long term stability of the channel. However, R1b was closer to the second stage of the E→C→Gc→F→C→E stream succession as indicated by the incision in cross section 5 and the entrenchment in cross section 6. The degradation processes in the lower portion of the reach were most likely tied to the dredging operation in Muddy Creek. Therefore, the decision to divert the channel to R2 now requires measures be taken to stabilize R2 as it now provides the hydrologic and aquatic connection to Muddy Creek.

5.1.6 Proposed Design Reach 2 (R2)

The work along R2 will consist of the replacement of a degraded culvert causing restrictive water passage effectively removing any hydrologic and aquatic connection to Muddy Creek while increasing erosive forces immediately downstream of the crossing. The existing pipe is an 18 inch corrugated metal pipe (CMP) with a buried inlet and a perched outlet approximately 3 feet above bed elevation. The downstream section of R2 is extremely incised and entrenched as a result of the perched pipe and active dredging occurring in Muddy Creek. Simply removing the degraded culvert would remove agricultural access and create an unstable transition in elevation which would result in a severe head cut moving upstream. Therefore the design must maintain agricultural access, provide vertical stability, and reconnect the aquatic passage of the upstream reach to Muddy Creek.

A 112 inch by 75 inch corrugated aluminum arch pipe (CAAP) was selected based on stream channel size and because this type of pipe can be easily modified to incorporate a baffling system. The baffling system is installed in such a manner as to create a sinuous low flow path through the pipe that encourages fish passage. The 75 inch height of the pipe coupled with a 1.15 foot headwall matches the existing grades of the surrounding banks allowing for easy path construction. The original drainage area of the culvert was 0.64 mi² before diverting R1 into R2 upstream of the culvert. Including R1, the new drainage area for the culvert is 1.13 mi² which based on an ungauged station analysis of that size produces a 2 year design discharge of 172 cfs and a 5 year design discharge of 319 cfs. Taking into account the baffling system, the flow path of this pipe is reduced to an equivalent pipe size of an 87 inch by 63 inch CAAP. The baffling system also effectively raised the invert elevation of the pipe to the invert of the first baffle. Accounting for these hydraulic changes, an analysis of the pipe determined the 5 year return interval caused the water to overtop the farm path by 2.41 feet whereas the 2 year return interval placed the water 1.5 feet below the road. As the pipe is installed to provide agricultural access, to allow for fish passage, and is completely contained within NCDOT's right of way; these hydraulic conditions were deemed acceptable for the purpose. The baffled pipe system will provide for the aquatic and hydrologic connection now missing throughout R1 and R2. Specific details of the pipe design can be found in Appendix G and in Appendix H within the details of the construction plans.

5.1.7 Stream Riparian Planting Plan

A protected riparian buffer will be established as part of the on-site mitigation and the entire conservation easement will be fenced to restrict access to the restored areas and the SR 3000 right-of-way. The planting plan for the riparian and upland buffers of the U-2707 site will provide post-construction erosion control and riparian habitat enhancement. The planting plan will also attempt to blend existing vegetative communities into recently restored areas. Plantings in the buffer areas will include native species appropriate for the Piedmont physiographic province. Plants within the floodplain will be flood tolerant species, which can accommodate periodic flooding events throughout the year. A variety of trees will be planted to provide cover and habitat for wildlife as well as soil stabilization. NCDOT Roadside Environmental Unit will develop the specific details and plant lists to be utilized on the U-2707 restoration site.

Trees with extensive, deep rooting systems will assist in stabilizing the banks in the long term. Colonization of local herbaceous vegetation will inevitably occur, which will provide additional soil stability. Tree species will be planted as bare root stock on random 8-foot centers at a frequency of 680 stems per acre. Planting stock will be culled to remove inferior specimens, so only healthy, viable stock will be planted at the U-2707 restoration site. Planting of species will utilize dormant plant stock and will be performed to the extent practicable between December 1st and March 15th.

A complete Plan and Profile (Sheets MIT-03 and MIT-04) of the design described above along with the Planting Plan (Sheets PLT-03 and PLT-04) can be found in Appendix I. Specific details regarding construction and typicals of the stream can be found in Appendix H.

5.2 Construction Implementation

Construction activities associated with the implementation of the natural channel design outlined above will include excavation, structure installation, pipe removal and replacement, utility marking, and vegetation installation. Prior to any work, the permittee will be responsible for the knowledge and implementation of appropriate erosion control practices that meet all local, county, and state regulations. The use of a pump around system will be incorporated and where possible work will be conducted offline to minimize sediment input. Work will continue in a fashion that allows for any land disturbance to be adequately treated by the end of each day. Prior to any work beginning, the permittee will be responsible for marking all utilities on-site and to confirm the elevations and locations shown on the plans. Excavation will be performed by qualified personnel using equipment suitable for the conditions. Excavation will include cutting the channel, bankfull bench, and any work necessary to remove the existing culvert. To stabilize the banks, seed and straw will be immediately applied to the newly cut channel and covered with coir fiber matting. Structure installation will include the installation of rock (or log if deemed acceptable on site) cross vanes and constructed riffles. These structures are installed to provide grade control and offer bank protection so it is important qualified personnel use equipment outfitted for stream restoration. Similar to the structure installation, the pipe removal and replacement will require specialized equipment and personnel familiar with the installation of CAAPs and baffling systems. The last phase of construction will consist of planting the conservation easement. As the vegetation is as important as the channel construction and structure installation, the vegetation should be installed by a qualified landscaper or person of similar background. This site will require the installation of bare root stock and live stake material, each of which requires particular handling and installation for manual installation.

6.0 PERFORMANCE STANDARDS

The NCDOT shall monitor stream channel stability and buffer vegetation survival on the site. Post-restoration monitoring will be conducted for a minimum of five years or until the success criteria are met following the completion of construction to document project success. Monitoring approaches follow those recommended by the Stream Mitigation Guidelines (USACE and NCDWQ 2003). These approaches are described below in Section 7.0.

7.0 MONITORING REQUIREMENTS

The stream mitigation site will be monitored for five years or until success criteria is satisfied. Monitoring protocols shall follow the Monitoring Level 1 outlined in the Stream Mitigation Guidelines, April 2003. NCDOT will evaluate the success of the stream restoration project based on guidance provided by the Stream Mitigation Guidelines disseminated by the United States Army Corps of Engineers- Wilmington District. The survey of the channel dimension will consist of permanent cross sections placed at equal number of pools and riffles. Annual photographs showing both banks and upstream and downstream views will be taken from permanent, mapped photo points. The survey of the longitudinal profile will represent distinct areas of the stream and cover a cumulative total of approximately 1,800 linear feet LF of channel. The entire restored length of stream will be investigated for channel stability and in-stream structure functionality. Any evidence of channel instability will be identified, mapped and photographed.

8.0 OTHER INFORMATION

No other information is available.

9.0 DETERMINATION OF CREDITS

Restoration						
Stream	Station	Priority Level	Type	Existing Length of Channel (lf)	Proposed Length of Channel (lf)	Stream Mitigation Units (SMU)
Reach 1	0+00 to 9+20	I	Perennial	920	920	920
Reach 1	9+20 to 11+22	II	Perennial	202	202	202
Relocation						
Stream	Station	Priority Level	Type	Existing Length of Channel (lf)	Proposed Length of Channel (lf)	Stream Mitigation Units (SMU)
Reach 1	11+22 to 18+00	II	Perennial	863	678	678
Enhancement						
Stream	Station	Priority Level	Type	Existing Length of Channel (lf)	Proposed Length of Channel (lf)	Stream Mitigation Units (SMU)
Reach 2	0+00 to 1+53	II	Perennial	153	153	76.5
			Total	2138	1953	1876.5

The site will be debited at the following ratios: 1:1 for stream restoration and 2:1 for stream enhancement to mitigate for the 903 linear feet of stream impacts associated with U-2707. An as-built report will be submitted within 60 days of completion of the project to verify final feet of mitigation. The success of the mitigation areas and determination of final credits will be based upon successful completion of the monitoring.

No wetland credit is currently proposed. However, there is potential for wetland restoration within the floodplain of Reach 1. Any wetland restoration will be documented during the monitoring phase and addressed with the agencies at a future time.

9.1 Credit Release Schedule

NCDOT proposes immediate, full release of the stream restoration and enhancement and the wetland restoration as on-site mitigation for the impacts associated with U-2707. Any mitigation not debited for U-2707 will be placed on the NCDOT debit ledger for future use on other projects.

10.0 GEOGRAPHIC SERVICE AREA

The U-2707 Mitigation Plan has been developed to provide on-site mitigation for unavoidable stream impacts associated with the construction of Transportation Improvement Project (TIP) number U-2707, or the Idols Road Extension (SR 3000) in Forsyth County, North Carolina near the town of Clemmons. The Site is situated within the Yadkin-Pee Dee River Basin within the US Geological Survey (USGS) hydrological unit code (HUC) 03040101 and the NC Division of Water Quality (NCDWQ) sub-basin 03-07-04. All stream and wetland mitigation assets not

compensate for impacts beyond the GSA may be considered by the Corps or the permitting agency on a case-by-case basis.

11.0 MAINTENANCE PLAN

The Site will be held by NCDOT and placed on the NEU mitigation geodatabase. If an appropriate third party recipient is identified in the future, then the transfer of the property will include a conservation easement or other measure to protect the natural features and mitigation value of the site in perpetuity.

12.0 LONG TERM ADAPTIVE MANAGEMENT PLAN

The Site will be managed by the NCDOT according to the site plans. In the event that unforeseen issues arise that affect the management of the site, any remediation will be addressed by NCDOT in coordination with the Interagency Review Team.

13.0 FINANCIAL ASSURANCES

The Site is will be managed by NCDOT with its own distinct cost center number within the NCDOT budgeting and financial tracking system. Therefore, all accounting for revenues, contract encumbrances, fund transfers, and expenses will be performed and reported independent from other capital budget or operating budget accounting.



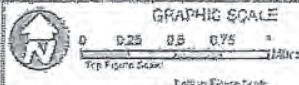

VICINITY MAP
L2707 STREAM RESTORATION

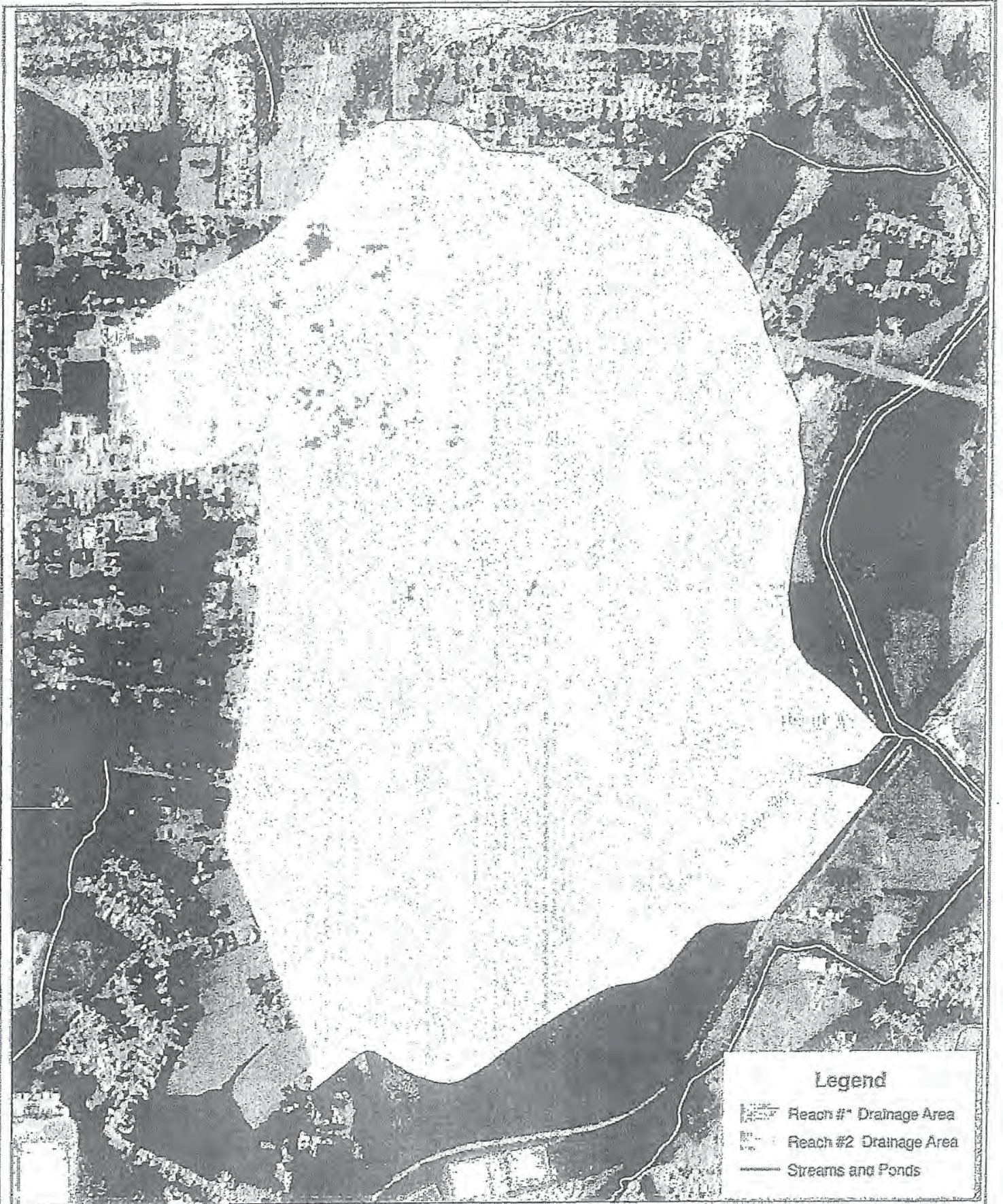

FIGURE



Legend

-  Reach #1 Drainage Area
-  Reach #2 Drainage Area
-  Streams and Ponds



PREPARED FOR:
DRAINAGE AREA MAP
U-2707 STREAM RESTORATION
FORSYTH COUNTY NORTH CAROLINA



1 inch = 1,000 feet
GRAPHIC SCALE
0 250 500 1,000 Feet
Scale: 11
From: 7/26/2014; EGIS Images From: World 2D

FIGURE

2

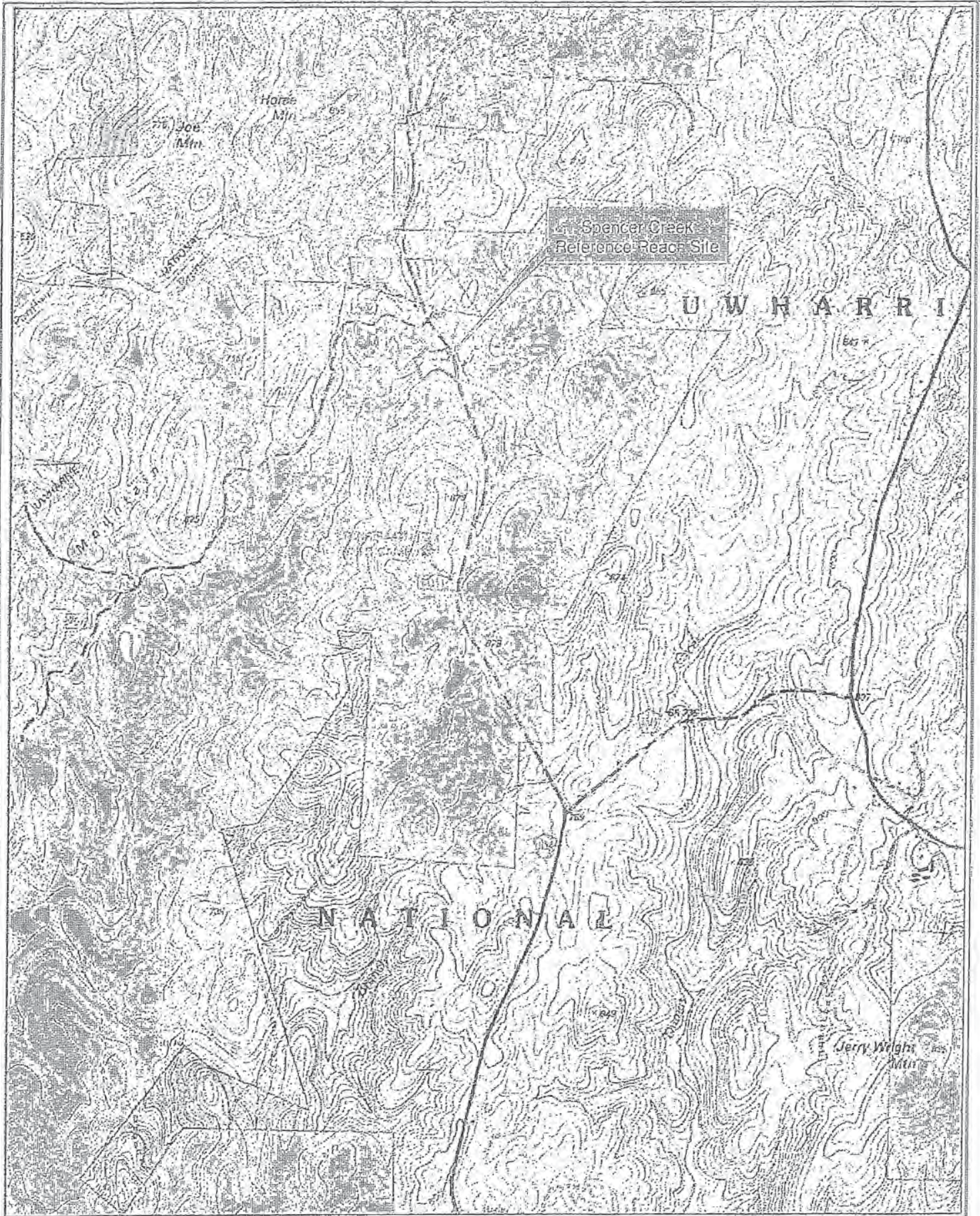

PREPARED FOR:
REFERENCE REACH VICINITY MAP
SPENCER CREEK
MONTEGOMERY COUNTY NORTH CAROLINA



1 inch = 2,000 feet
GRAPHIC SCALE
0 500 1,000 2,000 Feet
Map by
Wright & Gray, Terrain Maps and Fly Maps

FIGURE
3

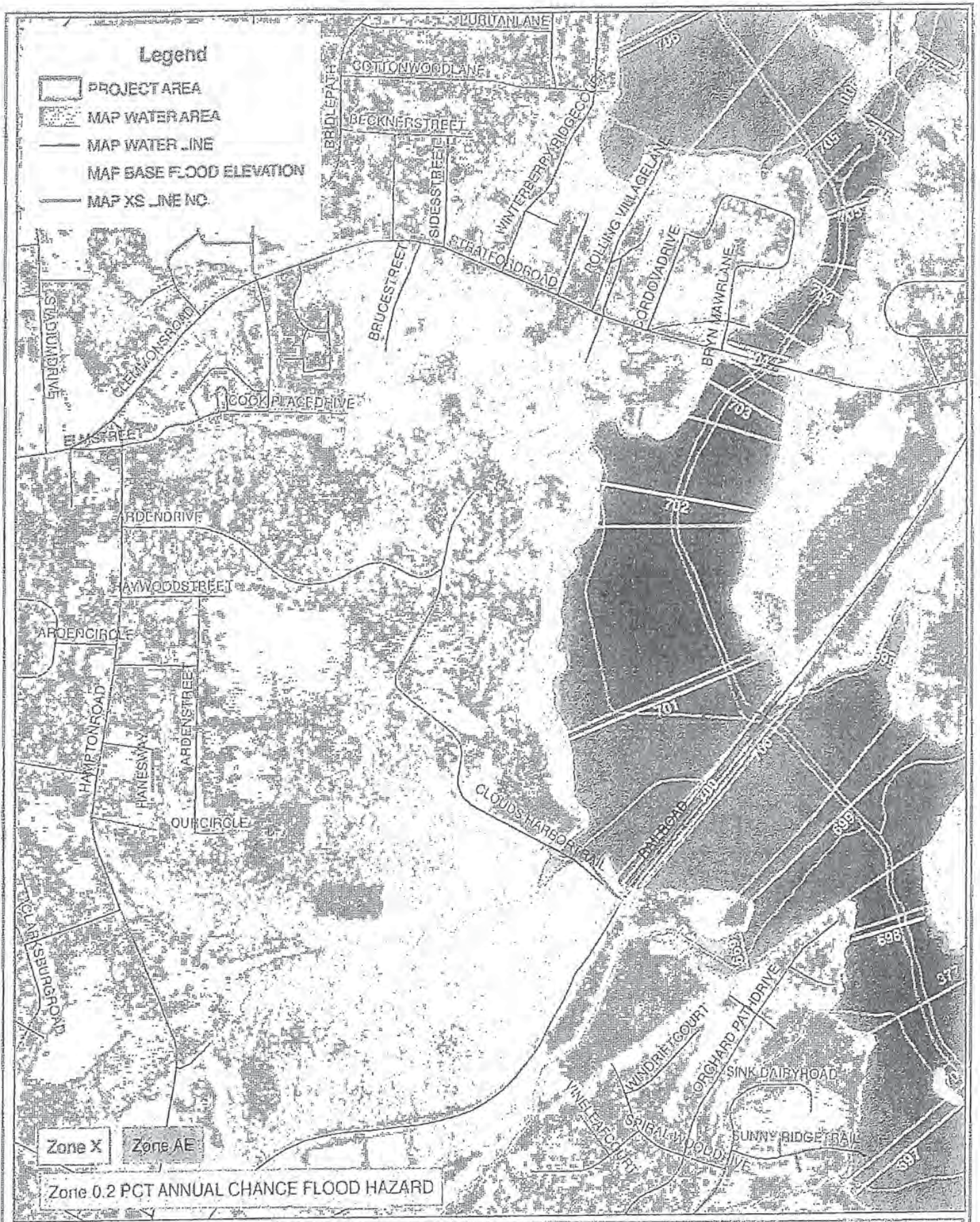

- Legend**
- PROJECT AREA
 - MAP WATER AREA
 - MAP WATER LINE
 - MAP BASE FLOOD ELEVATION
 - MAP XS LINE NC

Zone X Zone AE

Zone 0.2 PCT ANNUAL CHANCE FLOOD HAZARD



PREPARED FOR:
FEMA FLOOD MAP
 J-2707 STREAM RESTORATION
 FORSYTH COUNTY, NORTH CAROLINA

GRAPHIC SCALE
 0 250 500 1,000 Feet
 1 inch = 1,000 feet

FIGURE
4

U-2707 Existing Conditions Longitudinal Profile Reach 1

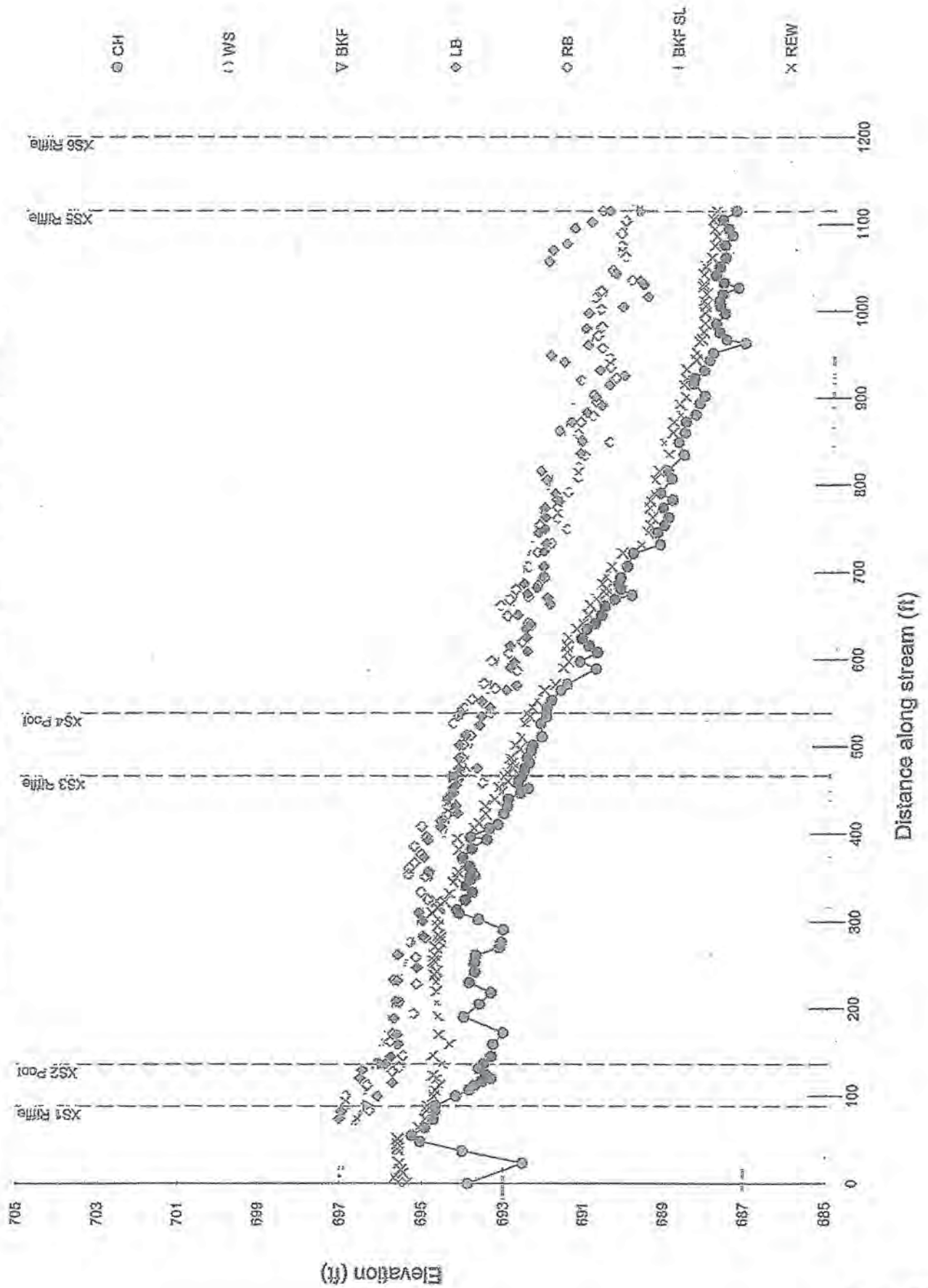

P-54

RIVERMORPH PROFILE SUMMARY

River Name: UT to Muddy Creek
 Reach Name: Existing Conditions
 Profile Name: Longitudinal Profile
 Survey Date: 06/29/2011

Survey Data

DIST	CH	WS	BKF	LB	RB	BKF SL	REW
0	693.86						
0.625							695.585
0.795							695.353
6.222							695.661
11.832							695.451
15.196							695.501
15.91							695.508
23.074	692.516						
23.074							695.545
35.993							695.56
36.912	694.001						
39.507							695.59
44.881							695.587
47.663	695.034						
50.396							695.575
50.837							695.603
54.722	695.233						
63.645	694.927						
63.749							695.075
73.117							694.928
73.2	694.716						
73.794							696.585
74.078				697.024			
81.249				696.974			
82.706							694.882
82.877	694.668						
83.024					696.285		
88.5	694.665		696.299		696.869		694.87
99.124				696.086			
99.525							694.727
99.892	694.174						
99.892					696.881		
106.129							694.688
106.979	693.842						
111.923	693.713						
111.923							694.588
111.923					696.35		
114.753				695.735			
116.742	693.546						
120.095							694.643
120.095	693.327						
120.095				696.526			
123.141							694.746
124.212	693.447						
127.768					695.745		

P-55

331.674			694.404
333.534		695.1	
333.534	693.833		
341.028	693.983		
344.937			694.318
347.63	693.888		
350.418			694.232
350.989		694.992	
351.841	693.909		
352.811	693.785		
353.7		695.413	
356.197		694.921	
356.197	693.848		
356.197			694.193
360.804		695.4	
363.215	693.916		
366.921		695.264	
373.203	694.087		
373.203		695.039	
376.582		695.1	
382.241			694.189
383.637	693.86		
385.519		695.283	
392.281		694.947	
394.032	693.489		
394.708			694.231
396.542	693.895		
396.542		694.983	
406.39	693.427		
406.39			693.818
407.997		694.636	
408.593		695.107	
411.161	693.223		
412.037			693.689
414.26		694.637	
421.844		694.472	
423.082		694.23	
423.112			693.533
423.112	693.091		
431.014		694.461	
431.317	693		
431.771			693.552
431.95		694.27	
438.872		694.468	
439.792			693.326
440.087	692.974		
440.898		694.469	
447.108	692.673		
447.108		694.336	
447.599			693.155
447.965		694.327	
451.908	692.477		
453.145		694.334	
453.145			693.216
455.345		694.274	
457.389	692.731		
458.313		693.628	
460.023			693
461.541	692.719		
461.805		694.221	
465.5	692.641	694.21	694.318 693.093

P-56

625.309		692.564	
635.241			691.314
635.241		692.584	
635.241	691.053		
639.735		692.456	
640.767		692.468	
641.297			691.153
641.691	690.848		
641.736		692.528	
650.351		693.056	
650.769	690.701		
650.95		692.803	
651.129			691.021
661.495		693.23	
661.495	690.612		
662.436			690.982
663.46		691.985	
668.731		693.003	
669.118	690.381		
669.382			690.833
671.086		692.052	
671.777		692.542	
674.104	689.955		
674.957			690.586
675.335		692.563	
680.051		692.856	
680.753	690.225		
681.12			690.595
682.151		692.329	
685.566		692.309	
686.997			690.676
686.997	690.274		
686.997		692.646	
693.424		692.137	
693.924	690.233		
695.323			690.603
695.537		692.141	
705.96		692.541	
706.456		692.155	
706.756			690.457
707.13	690.071		
722.031	689.925		
722.184			690.19
722.943		692.317	
723.709		692.153	
731.686			689.726
731.904	689.253		
732.747		692.102	
733.164		691.973	
745.342		692.299	
745.836	689.319		
745.836			689.559
749.539		691.573	
749.97		692.149	
753.833			689.499
754.193	689.151		
754.193		692.271	
762.004		691.827	
762.787			689.452
763.028	689.046		
763.028		692.123	

P-57

957.256			690.742	
960.778		691.1		
962.98	687.184			
964.518				688.335
967.327	687.656			
967.836				688.282
971.514			690.857	
975.646	687.834			
975.995				688.236
980.071		691.151		
981.588			690.764	
985.416	687.921			
985.997				688.206
997.44		691.088		
997.44	687.703			
998.031				688.206
1001.877			690.787	
1005.131		690.245		
1006.051				688.196
1006.249	687.822			
1011.827				688.239
1011.827	687.846			
1015.221			690.939	
1016.241		689.619		
1019.807	687.764			
1019.807				688.177
1023.383			690.792	
1026.997	687.379			
1027.94				688.254
1030.424		689.739		
1031.593				688.248
1032.83	687.738			
1035.472		689.825		
1035.601			690.031	
1041.331	687.937			
1042.459				688.245
1043.257		690.429		
1047.057			690.508	
1051.403	687.839			
1051.518				688.201
1056.684		692.099		
1061.414	687.705			
1061.725				688.05
1062.482			690.197	
1069.657		691.999		
1075.188			690.292	
1075.529				687.982
1076.185	687.725			
1077.718		691.654		
1086.712				687.934
1087.274	687.538			
1089.763			690.297	
1094.75				687.992
1094.998	687.641			
1095.412		691.461		
1102.243		691.038		
1103.956			690.189	
1105.034				688.029
1105.204	687.774			
1115	687.445	689.806	690.588	690.765
				689.806
				687.945

U2707 R1 XS1 Riffle

▽ Water Surface Points
Alt/xf = 9.86

◆ Bankfull Indicators
D/xf = .85

() XS1 Riffle
W/xf = 1.16

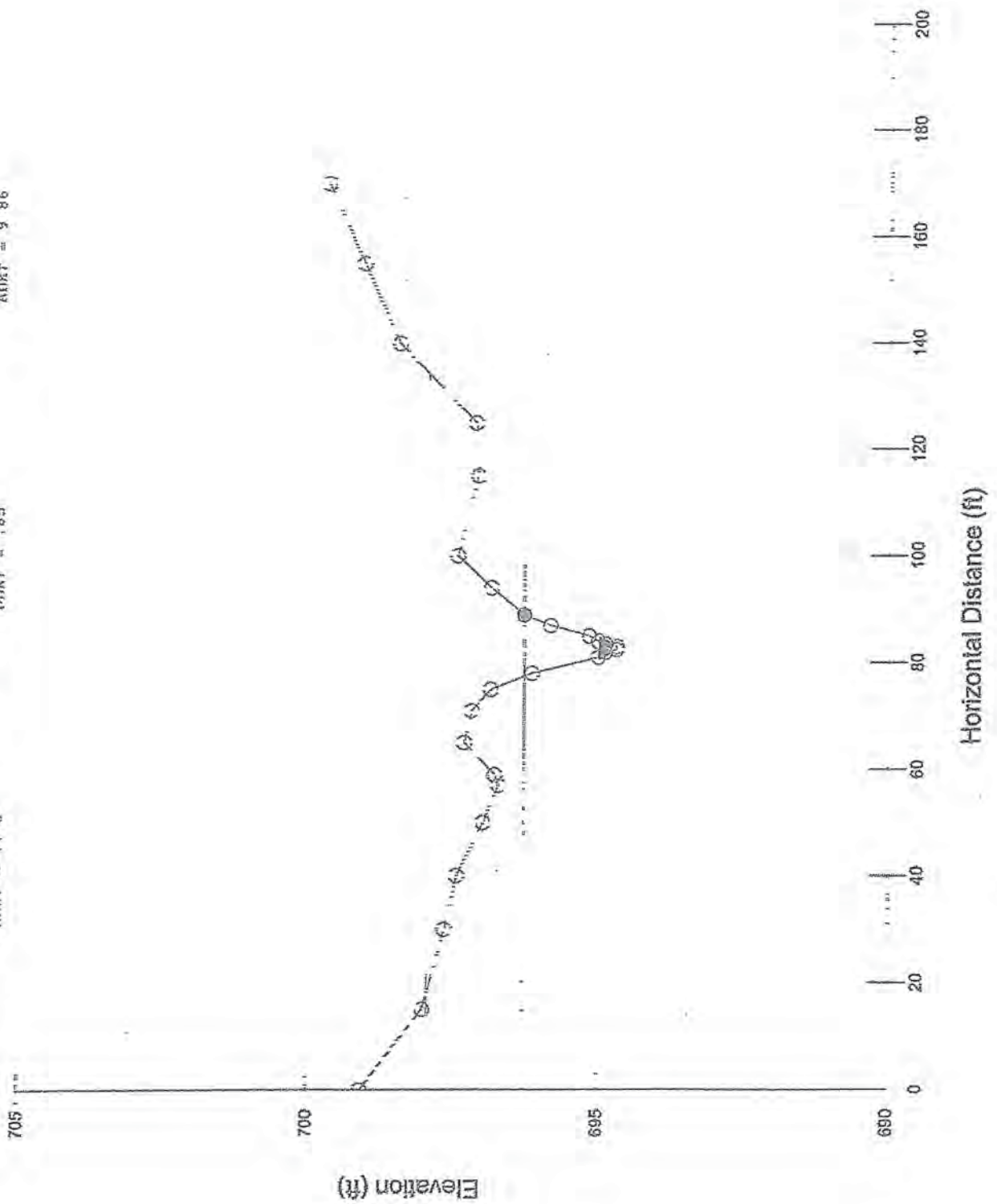

RIVERMORPH CROSS SECTION SUMMARY

 River Name: UT to Muddy Creek
 Reach Name: Existing Conditions
 Cross Section Name: XS1 Riffle
 Survey Date: 06/14/2011

Cross Section Data Entry

BM Elevation: 0 ft
 Backsight Rod Reading: 0 ft

TAPE	FS	ELEV	NOTE
0	0	699.0642	GS
15	0	698.0063	GS
30	0	697.6342	GS
40	0	697.4325	GS
50	0	696.9929	GS
57	0	696.7344	GS
59	0	696.7981	GS
65	0	697.3121	GS
71	0	697.1896	LB
75	0	696.8689	GS
78	0	696.1681	GS
81	0	694.9963	GS
82	0	694.8701	LEW
82.5	0	694.6763	TW
83	0	694.665	SB
83.5	0	694.8619	REW
84	0	694.9972	GS
85	0	695.1601	GS
87	0	695.8468	GS
89	0	696.2988	BKF
94	0	696.8665	GS
100	0	697.4391	RB
115	0	697.0983	GS
125	0	697.1365	GS
140	0	698.434	GS
155	0	699.0594	GS
170	0	699.6787	GS

 Cross Sectional Geometry

	Channel	Left	Right
Floodprone Elevation (ft)	697.94	697.94	697.94
Bankfull Elevation (ft)	696.3	696.3	696.3
Floodprone width (ft)	116.36	-----	-----
Bankfull width (ft)	11.58	5.35	6.22
Entrenchment Ratio	10.05	-----	-----
Mean Depth (ft)	0.85	0.9	0.81
Maximum Depth (ft)	1.63	1.63	1.63
Width/Depth Ratio	13.62	5.94	7.68
Bankfull Area (sq ft)	9.86	4.79	5.07
Channel Area (sq ft)	12.00	7.27	8.08

U2707 R1 XS2 Pool

▽ Water Surface Points
Abkf = 18.7

◆ Bankfull Indicators
Dbkf = 1.32

○ Ground Points
Wbkf = 14.2

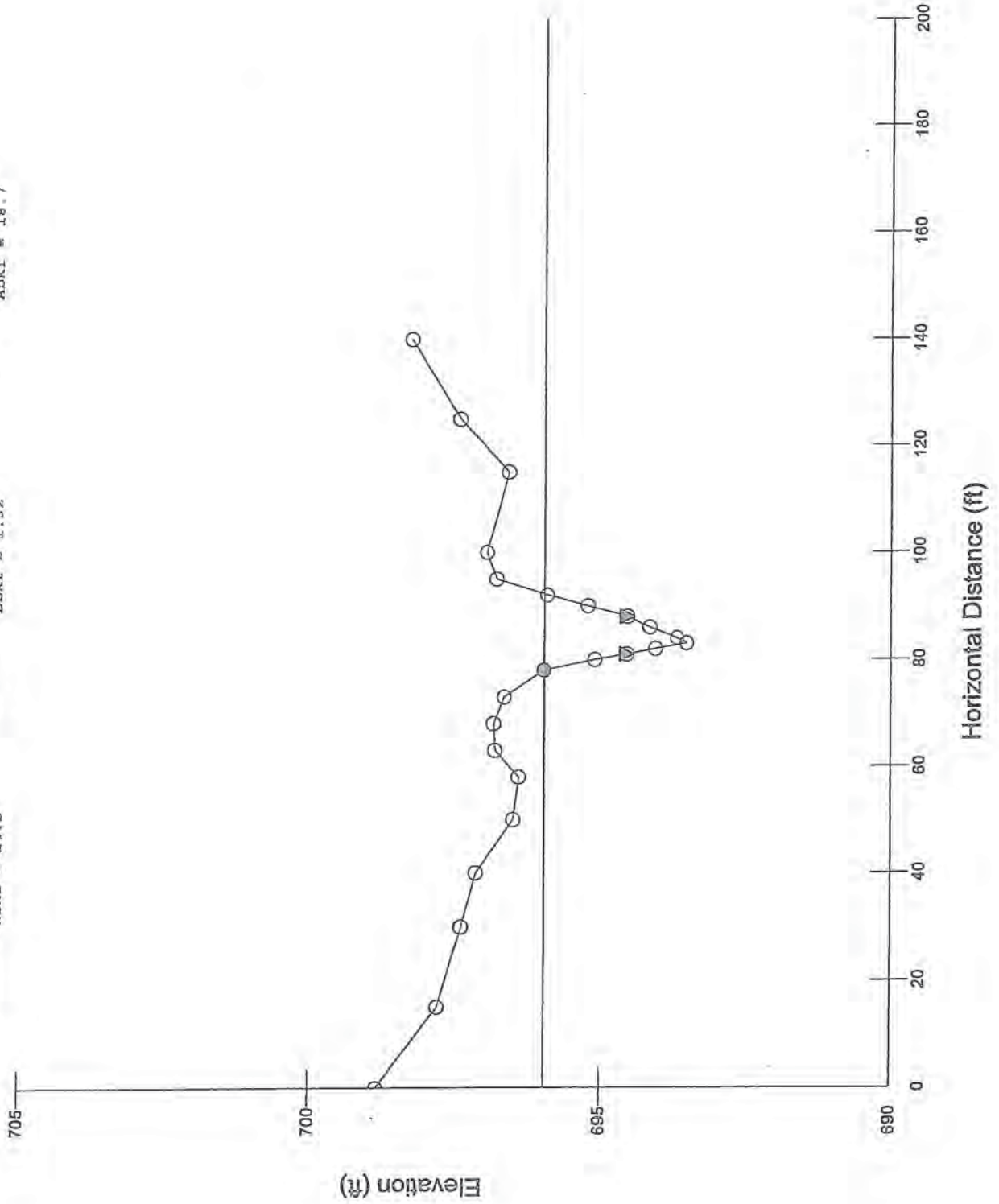

P-61

RIVERMORPH CROSS SECTION SUMMARY

River Name: UT to Muddy Creek
 Reach Name: Existing Conditions
 Cross Section Name: XS2 Pool
 Survey Date: 06/14/2011

Cross Section Data Entry

BM Elevation: 0 ft
 Backsight Rod Reading: 0 ft

TAPE	FS	ELEV	NOTE
0	0	698.8197	GS
15	0	697.7803	GS
30	0	697.3835	GS
40	0	697.1321	GS
50	0	696.4967	GS
58	0	696.4032	GS
63	0	696.8045	GS
68	0	696.83	GS
73	0	696.6516	GS
78	0	695.9671	BKF
80	0	695.0878	GS
81	0	694.5389	LEW
82	0	694.0439	SB
83	0	693.5011	TW
84	0	693.6753	SB
86	0	694.1423	SB
88	0	694.5287	REW
90	0	695.2058	GS
92	0	695.9111	RB
95	0	696.7802	GS
100	0	696.951	GS
115	0	696.5771	GS
125	0	697.406	GS
140	0	698.2313	GS

Cross Sectional Geometry

	Channel	Left	Right
Floodprone Elevation (ft)	698.44	698.44	698.44
Bankfull Elevation (ft)	695.97	695.97	695.97
Floodprone width (ft)	134.5	-----	-----
Bankfull width (ft)	14.22	7.11	7.11
Entrenchment Ratio	9.46	-----	-----
Mean Depth (ft)	1.32	1.5	1.13
Maximum Depth (ft)	2.47	2.47	2.04
Width/Depth Ratio	10.77	4.74	6.29
Bankfull Area (sq ft)	18.73	10.66	8.06
Wetted Perimeter (ft)	15.15	9.78	9.45
Hydraulic Radius (ft)	1.24	1.09	0.85
Begin BKF Station	77.98	77.98	85.09
End BKF Station	92.2	85.09	92.2

U2707 R1 XS3 Riffle

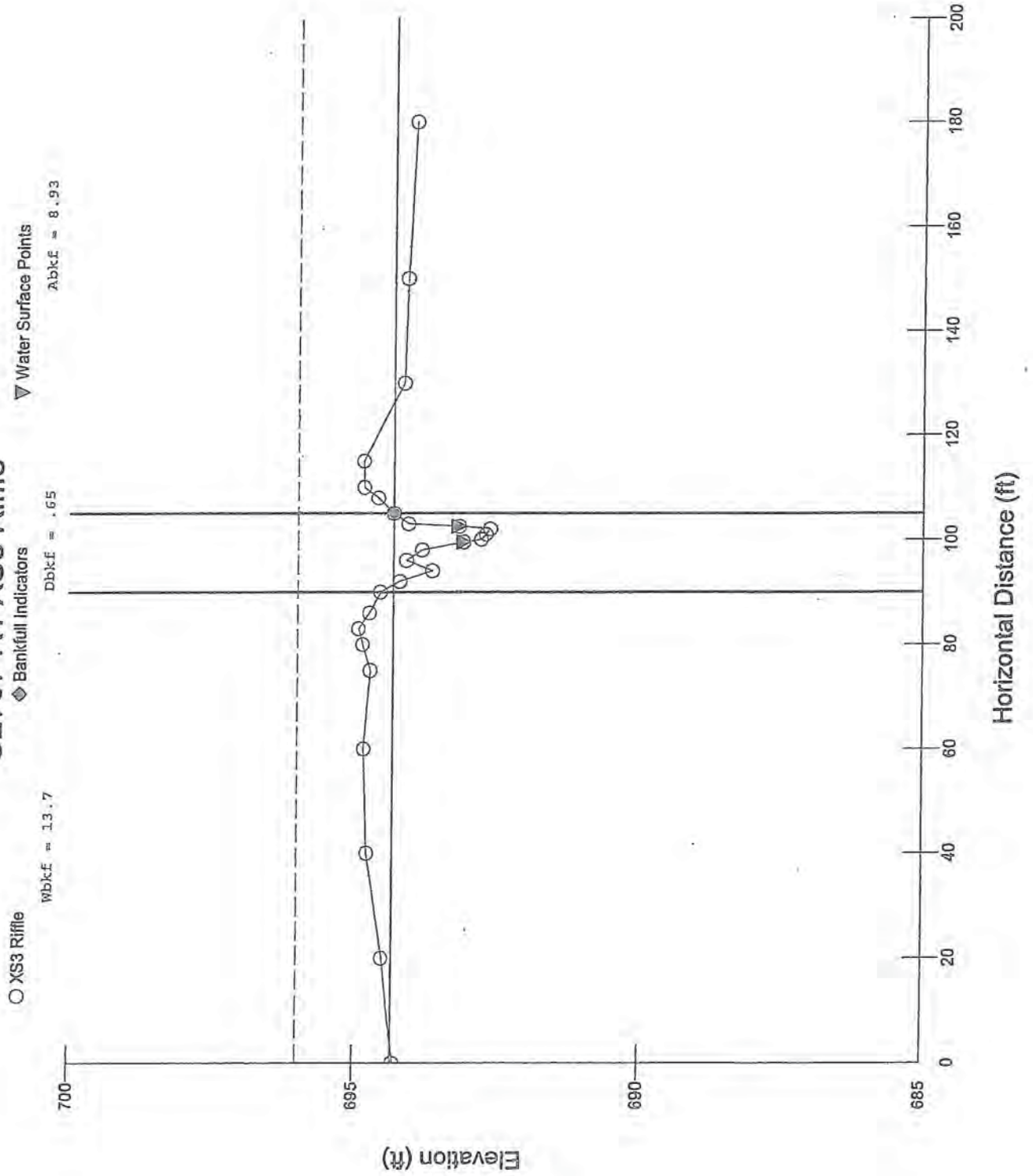

RIVERMORPH CROSS SECTION SUMMARY

River Name: UT to Muddy Creek
 Reach Name: Existing Conditions
 Cross Section Name: XS3 Riffle
 Survey Date: 06/14/2011

Cross Section Data Entry

BM Elevation: 0 ft
 Backsight Rod Reading: 0 ft

TAPE	FS	ELEV	NOTE
0	0	694.281	GS
20	0	694.4926	GS
40	0	694.768	GS
60	0	694.8287	GS
75	0	694.7147	GS
80	0	694.8549	GS
83	0	694.9303	LB
86	0	694.7372	GS
90	0	694.5439	GS
92	0	694.2099	GS
94	0	693.6444	GS
96	0	694.098	GS
98	0	693.8268	GS
99.5	0	693.0932	LEW
100	0	692.7944	SB
101	0	692.7124	SB
102	0	692.6413	TW
102.5	0	693.1772	REW
103	0	694.0695	GS
105	0	694.318	BKF
108	0	694.5922	GS
110	0	694.843	RB
115	0	694.8506	GS
130	0	694.1478	GS
150	0	694.0967	GS
180	0	693.961	GS

Cross Sectional Geometry

	Channel	Left	Right
Floodprone Elevation (ft)	696	696	696
Bankfull Elevation (ft)	694.32	694.32	694.32
Floodprone width (ft)	180	-----	-----
Bankfull width (ft)	13.66	9.09	4.57
Entrenchment Ratio	13.18	-----	-----
Mean Depth (ft)	0.65	0.56	0.84
Maximum Depth (ft)	1.68	1.56	1.68
Width/Depth Ratio	21.02	16.23	5.44
Bankfull Area (sq ft)	8.93	5.08	3.85
Wetted Perimeter (ft)	14.85	11.06	6.91
Hydraulic Radius (ft)	0.6	0.46	0.56

U2707 R1 XS4 Pool

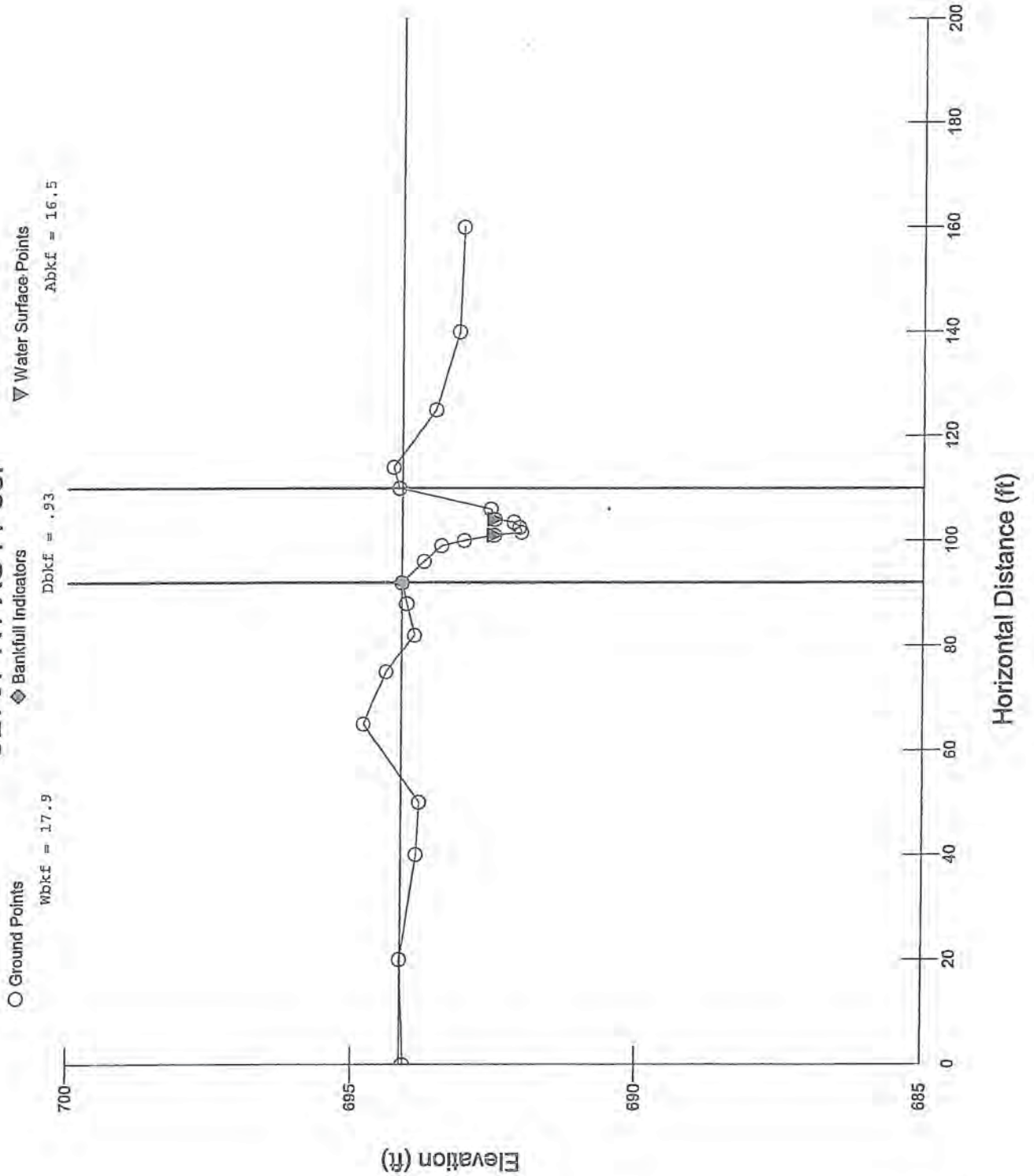

RIVERMORPH CROSS SECTION SUMMARY

River Name: UT to Muddy Creek
 Reach Name: Existing Conditions
 Cross Section Name: XS4 Pool
 Survey Date: 06/14/2011

Cross Section Data Entry

BM Elevation: 0 ft
 Backsight Rod Reading: 0 ft

TAPE	FS	ELEV	NOTE
0	0	694.0738	GS
20	0	694.1469	GS
40	0	693.8737	GS
50	0	693.8238	GS
65	0	694.796	GS
75	0	694.4041	GS
82	0	693.9102	GS
88	0	694.0461	GS
92	0	694.1282	BKF
96	0	693.7505	GS
99	0	693.4465	GS
100	0	693.057	GS
101	0	692.5303	LEW
101.5	0	692.0527	TW
102.5	0	692.086	SB
103.5	0	692.191	SB
104	0	692.522	REW
106	0	692.5926	GS
110	0	694.18253	RB
114	0	694.283555	GS
125	0	693.552789	GS
140	0	693.149204	GS
160	0	693.080396	GS

Cross Sectional Geometry

	Channel	Left	Right
Floodprone Elevation (ft)	696.21	696.21	696.21
Bankfull Elevation (ft)	694.13	694.13	694.13
Floodprone width (ft)	160	-----	-----
Bankfull width (ft)	17.87	11.58	6.29
Entrenchment Ratio	8.95	-----	-----
Mean Depth (ft)	0.93	0.84	1.09
Maximum Depth (ft)	2.08	2.08	1.89
Width/Depth Ratio	19.22	13.79	5.77
Bankfull Area (sq ft)	16.55	9.7	6.85
Wetted Perimeter (ft)	18.7	13.92	8.55
Hydraulic Radius (ft)	0.88	0.7	0.8
Begin BKF Station	92	92	103.58
End BKF Station	109.87	103.58	109.87

U2707 R1 XS5 Riffle

▽ Water Surface Points
Abkf = 1.4

◆ Bankfull Indicators
Dbkf = 1.58

○ XS5 Riffle
Wbkf = 8.86

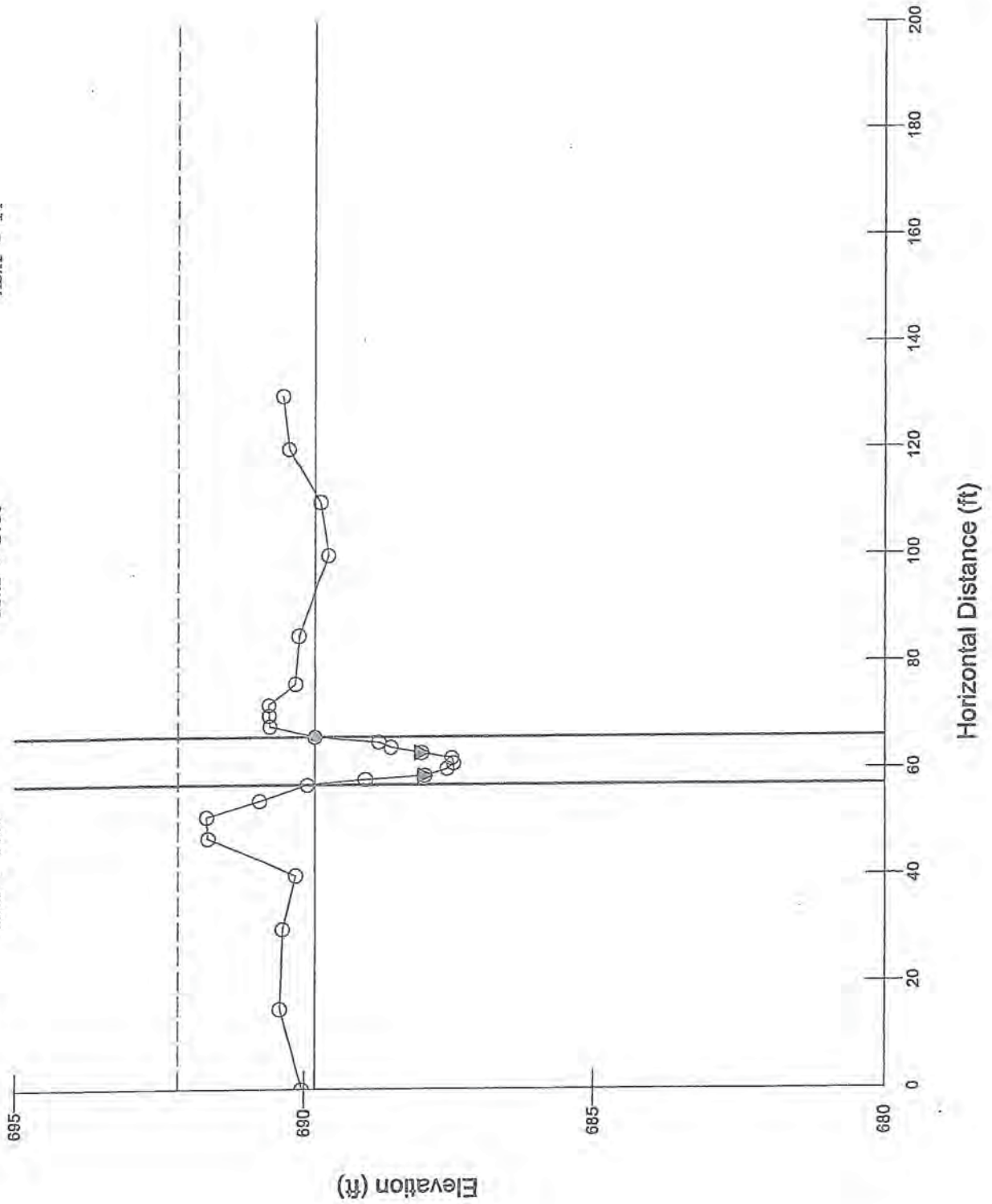

P-67

RIVERMORPH CROSS SECTION SUMMARY

River Name: UT to Muddy Creek
 Reach Name: Existing Conditions
 Cross Section Name: XS5 Riffle
 Survey Date: 06/14/2011

Cross Section Data Entry

BM Elevation: 0 ft
 Backsight Rod Reading: 0 ft

TAPE	FS	ELEV	NOTE
0	0	690.032	GS
15	0	690.4106	GS
30	0	690.3663	GS
40	0	690.1402	GS
47	0	691.6543	GS
51	0	691.681	LB
54	0	690.765	GS
57	0	689.9441	GS
58	0	688.9531	GS
58.7	0	687.9453	LEW
60	0	687.5588	SB
61	0	687.4447	TW
62	0	687.4768	SB
63	0	687.9997	REW
64	0	688.5247	GS
65	0	688.7279	GS
66	0	689.8061	BKF
68	0	690.5877	RB
70	0	690.5979	GS
72	0	690.606	GS
76	0	690.1461	GS
85	0	690.0836	GS
100	0	689.5855	GS
110	0	689.7192	GS
120	0	690.2572	GS
130	0	690.3618	GS

Cross Sectional Geometry

	Channel	Left	Right
Floodprone Elevation (ft)	692.18	692.18	692.18
Bankfull Elevation (ft)	689.81	689.81	689.81
Floodprone width (ft)	130	-----	-----
Bankfull width (ft)	8.86	1.93	6.93
Entrenchment Ratio	14.66	-----	-----
Mean Depth (ft)	1.58	1.05	1.73
Maximum Depth (ft)	2.37	1.97	2.37
Width/Depth Ratio	5.61	1.84	4.01
Bankfull Area (sq ft)	14	2.03	11.97
Wetted Perimeter (ft)	10.56	4.81	9.7
Hydraulic Radius (ft)	1.33	0.42	1.23

U2707 R1 XS6 Riffle

○ XS6 Riffle

Wbkf = 14.8

◆ Bankfull Indicators

Dbkf = .9

▽ Water Surface Points

Abkf = 13.3

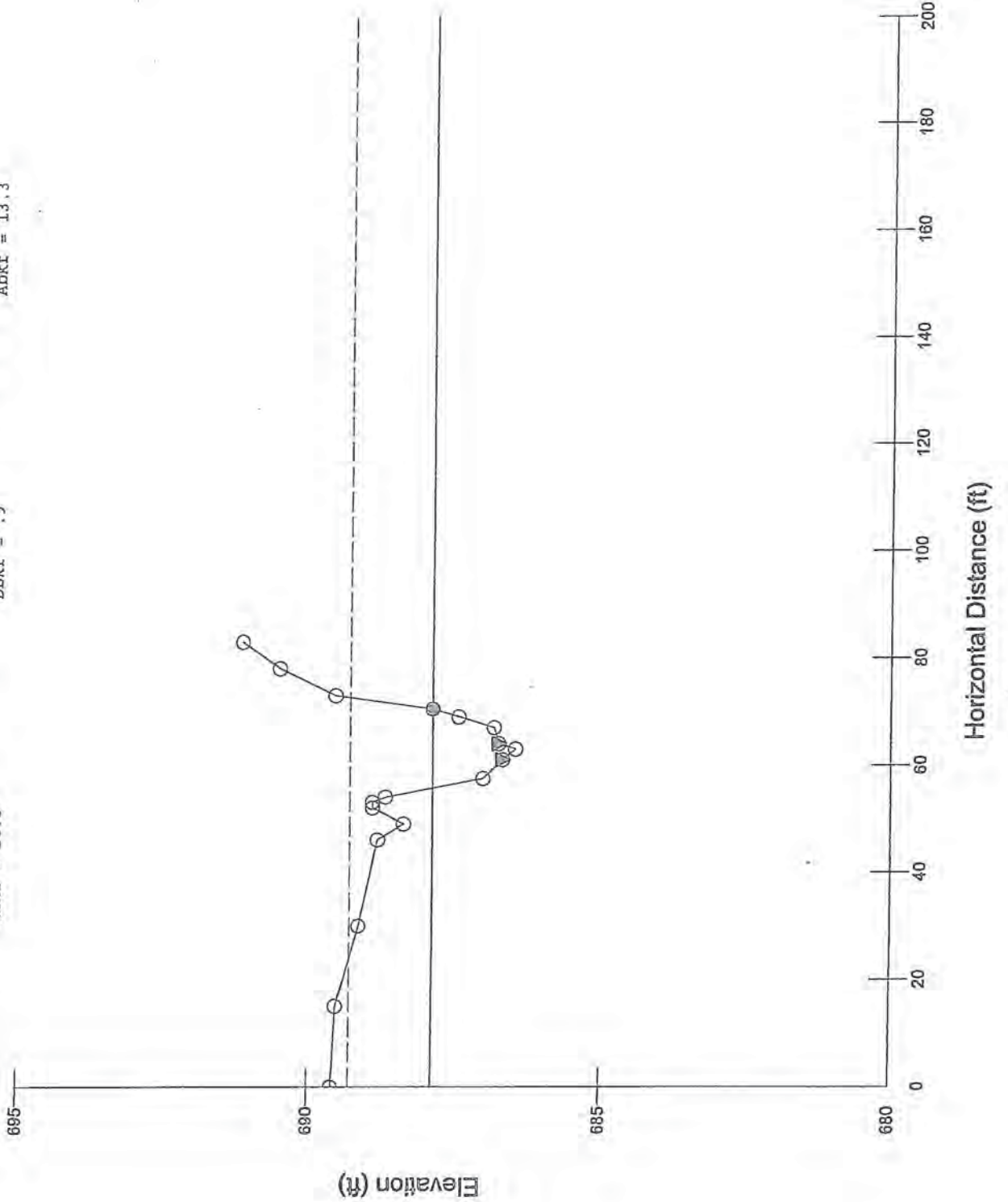

RIVERMORPH CROSS SECTION SUMMARY

River Name: UT to Muddy Creek
 Reach Name: Existing Conditions
 Cross Section Name: XS6 Riffle
 Survey Date: 06/14/2011

Cross Section Data Entry

BM Elevation: 0 ft
 Backsight Rod Reading: 0 ft

TAPE	FS	ELEV	NOTE
0	0	689.5793	GS
15	0	689.5134	GS
30	0	689.1252	GS
46	0	688.8049	GS
49	0	688.3591	GS
52	0	688.8873	GS
53	0	688.8949	LB
54	0	688.6721	GS
57.5	0	687.0096	GS
61	0	686.678	LEW
63	0	686.4578	TW
64	0	686.7395	REW
67	0	686.8219	GS
69	0	687.4243	GS
70.5	0	687.866	BKF
73	0	689.537	GS
78	0	690.4895	GS
83	0	691.1334	GS

Cross Sectional Geometry

	Channel	Left	Right
Floodprone Elevation (ft)	689.28	689.28	689.28
Bankfull Elevation (ft)	687.87	687.87	687.87
Floodprone width (ft)	48.69	-----	-----
Bankfull width (ft)	14.82	7.12	7.7
Entrenchment Ratio	3.29	-----	-----
Mean Depth (ft)	0.9	0.94	0.86
Maximum Depth (ft)	1.41	1.39	1.41
Width/Depth Ratio	16.47	7.57	8.95
Bankfull Area (sq ft)	13.35	6.71	6.64
Wetted Perimeter (ft)	15.23	8.73	9.28
Hydraulic Radius (ft)	0.88	0.77	0.71
Begin BKF Station	55.69	55.69	62.81
End BKF Station	70.51	62.81	70.51

Entrainment Calculations

U2707 R1 Reachwide Pebble Count

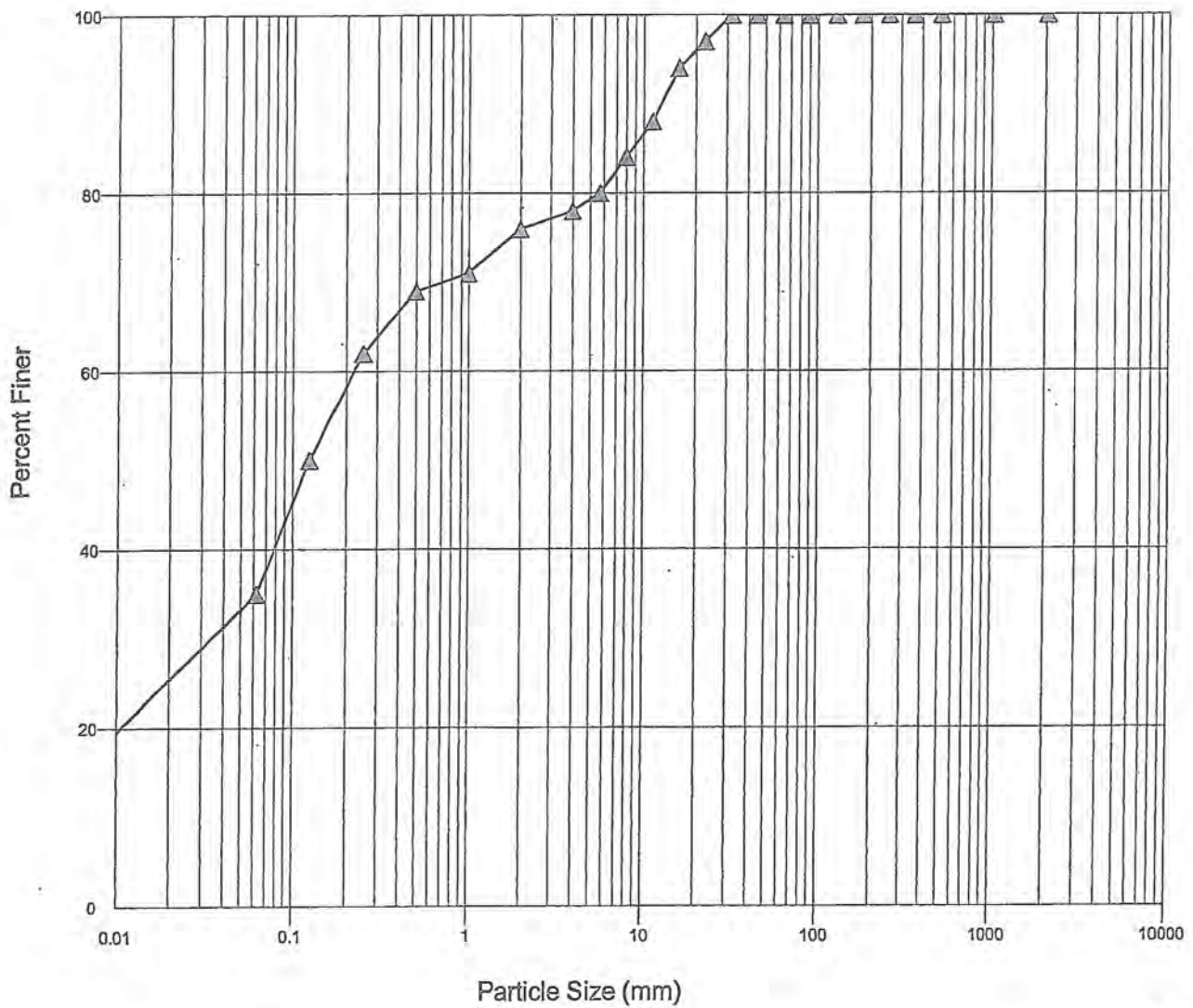

RIVERMORPH PARTICLE SUMMARY

 River Name: UT to Muddy Creek
 Reach Name: Existing Conditions
 Sample Name: U2707 R1 Reachwide
 Survey Date: 06/14/2011

Size (mm)	TOT #	ITEM %	CUM %
0 - 0.062	35	35.00	35.00
0.062 - 0.125	15	15.00	50.00
0.125 - 0.25	12	12.00	62.00
0.25 - 0.50	7	7.00	69.00
0.50 - 1.0	2	2.00	71.00
1.0 - 2.0	5	5.00	76.00
2.0 - 4.0	2	2.00	78.00
4.0 - 5.7	2	2.00	80.00
5.7 - 8.0	4	4.00	84.00
8.0 - 11.3	4	4.00	88.00
11.3 - 16.0	6	6.00	94.00
16.0 - 22.6	3	3.00	97.00
22.6 - 32.0	3	3.00	100.00
32 - 45	0	0.00	100.00
45 - 64	0	0.00	100.00
64 - 90	0	0.00	100.00
90 - 128	0	0.00	100.00
128 - 180	0	0.00	100.00
180 - 256	0	0.00	100.00
256 - 362	0	0.00	100.00
362 - 512	0	0.00	100.00
512 - 1024	0	0.00	100.00
1024 - 2048	0	0.00	100.00
Bedrock	0	0.00	100.00
D16 (mm)	0.03		
D35 (mm)	0.06		
D50 (mm)	0.13		
D84 (mm)	8		
D95 (mm)	18.2		
D100 (mm)	32		
Silt/Clay (%)	35		
Sand (%)	41		
Gravel (%)	24		
Cobble (%)	0		
Boulder (%)	0		
Bedrock (%)	0		

Total Particles = 100.

Active Riffle XS 1

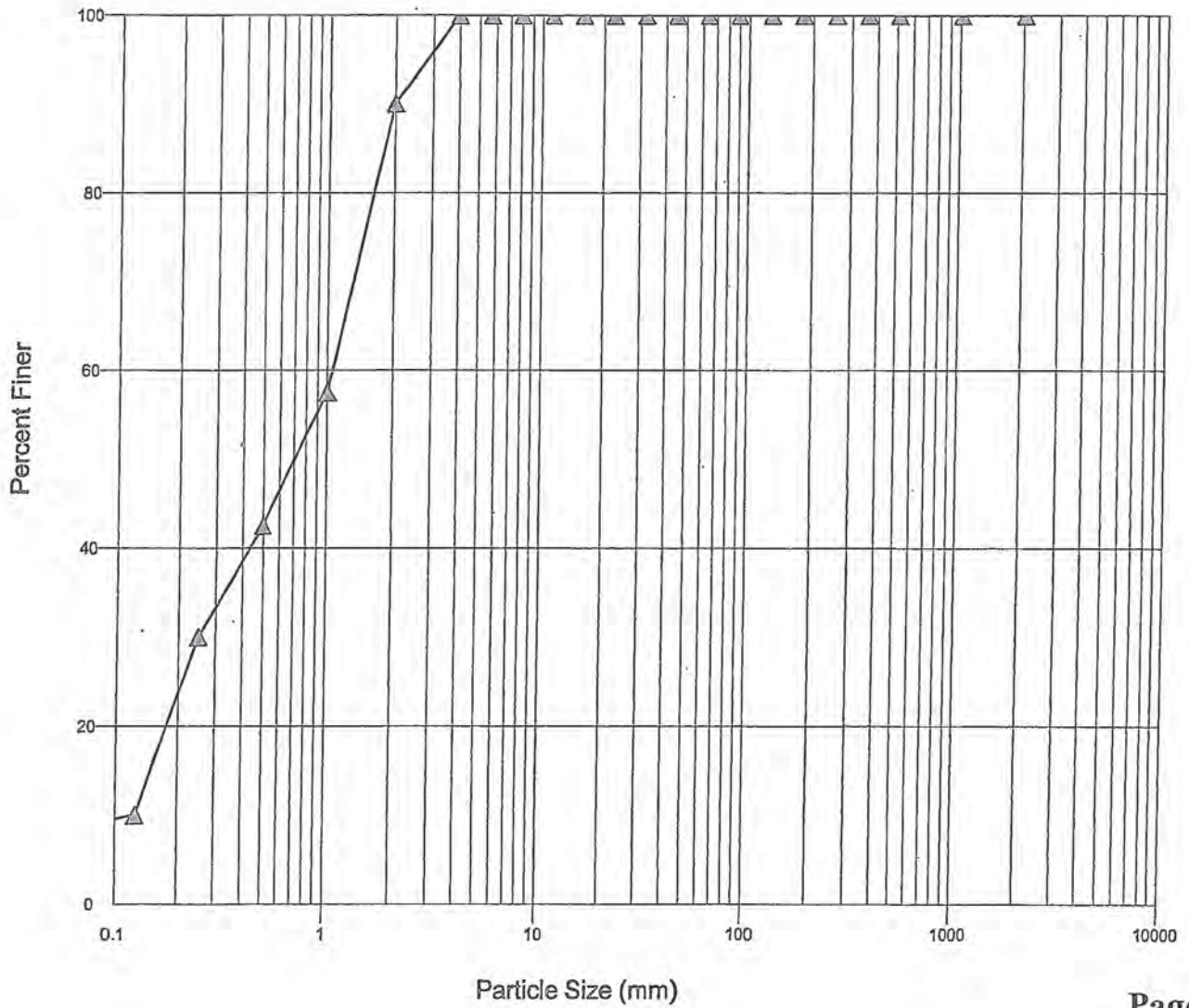

P-73

RIVERMORPH PARTICLE SUMMARY

River Name: UT to Muddy Creek
 Reach Name: Existing Conditions
 Sample Name: Active Riffle XS 1
 Survey Date: 11/30/2011

Size (mm)	TOT #	ITEM %	CUM %
0 - 0.062	0	0.00	0.00
0.062 - 0.125	4	10.00	10.00
0.125 - 0.25	8	20.00	30.00
0.25 - 0.50	5	12.50	42.50
0.50 - 1.0	6	15.00	57.50
1.0 - 2.0	13	32.50	90.00
2.0 - 4.0	4	10.00	100.00
4.0 - 5.7	0	0.00	100.00
5.7 - 8.0	0	0.00	100.00
8.0 - 11.3	0	0.00	100.00
11.3 - 16.0	0	0.00	100.00
16.0 - 22.6	0	0.00	100.00
22.6 - 32.0	0	0.00	100.00
32 - 45	0	0.00	100.00
45 - 64	0	0.00	100.00
64 - 90	0	0.00	100.00
90 - 128	0	0.00	100.00
128 - 180	0	0.00	100.00
180 - 256	0	0.00	100.00
256 - 362	0	0.00	100.00
362 - 512	0	0.00	100.00
512 - 1024	0	0.00	100.00
1024 - 2048	0	0.00	100.00
Bedrock	0	0.00	100.00
D16 (mm)	0.16		
D35 (mm)	0.35		
D50 (mm)	0.75		
D84 (mm)	1.82		
D95 (mm)	3		
D100 (mm)	4		
silt/clay (%)	0		
sand (%)	90		
Gravel (%)	10		
Cobble (%)	0		
Boulder (%)	0		
Bedrock (%)	0		

Total Particles = 40 (need at least 60).

Active Riffle XS 3

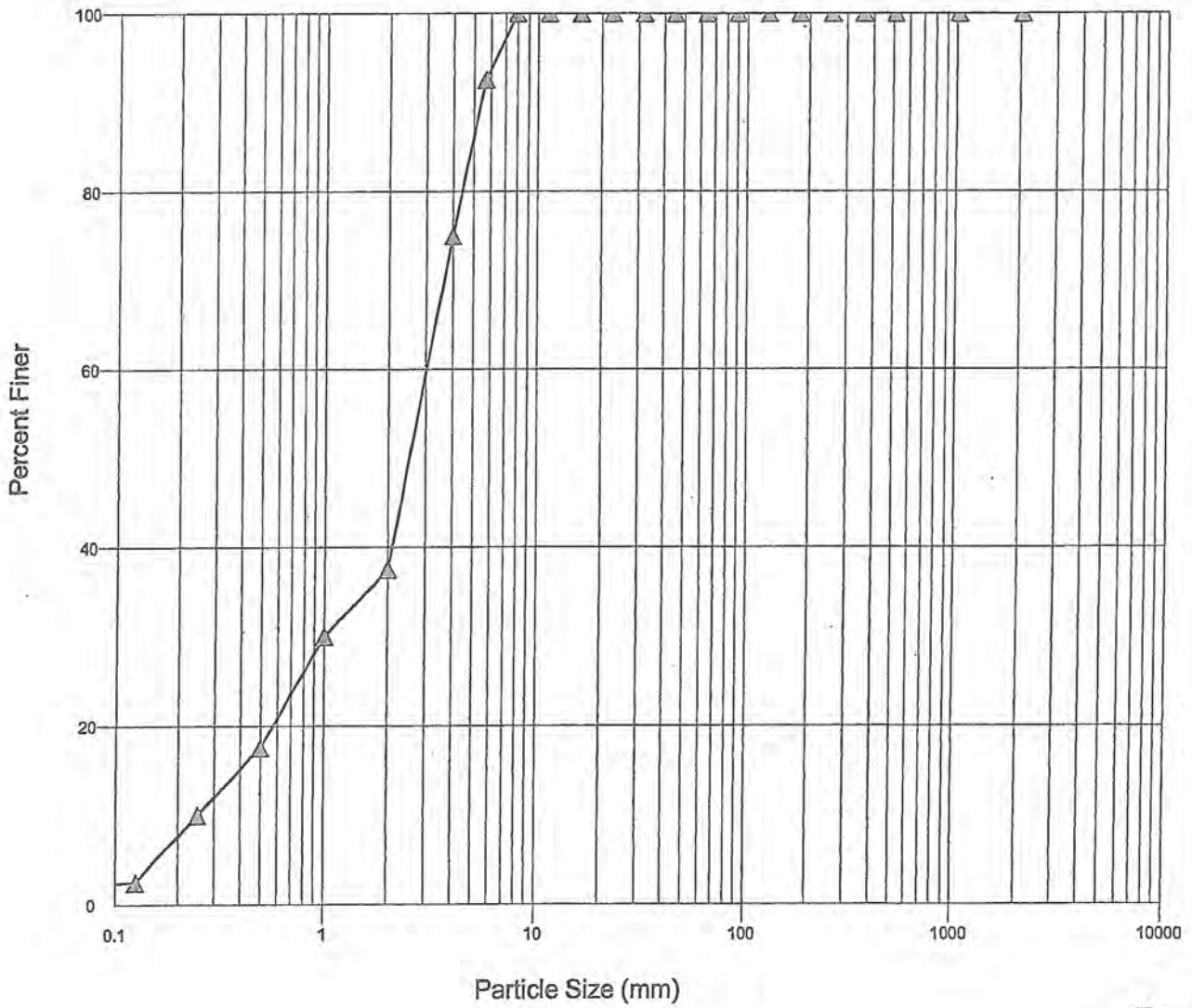

P-75

RIVERMORPH PARTICLE SUMMARY

River Name: UT to Muddy Creek
 Reach Name: Existing Conditions
 Sample Name: Active Riffle XS 3
 Survey Date: 11/30/2011

Size (mm)	TOT #	ITEM %	CUM %
0 - 0.062	0	0.00	0.00
0.062 - 0.125	1	2.50	2.50
0.125 - 0.25	3	7.50	10.00
0.25 - 0.50	3	7.50	17.50
0.50 - 1.0	5	12.50	30.00
1.0 - 2.0	3	7.50	37.50
2.0 - 4.0	15	37.50	75.00
4.0 - 5.7	7	17.50	92.50
5.7 - 8.0	3	7.50	100.00
8.0 - 11.3	0	0.00	100.00
11.3 - 16.0	0	0.00	100.00
16.0 - 22.6	0	0.00	100.00
22.6 - 32.0	0	0.00	100.00
32 - 45	0	0.00	100.00
45 - 64	0	0.00	100.00
64 - 90	0	0.00	100.00
90 - 128	0	0.00	100.00
128 - 180	0	0.00	100.00
180 - 256	0	0.00	100.00
256 - 362	0	0.00	100.00
362 - 512	0	0.00	100.00
512 - 1024	0	0.00	100.00
1024 - 2048	0	0.00	100.00
Bedrock	0	0.00	100.00
D16 (mm)	0.45		
D35 (mm)	1.67		
D50 (mm)	2.67		
D84 (mm)	4.87		
D95 (mm)	6.47		
D100 (mm)	8		
Silt/Clay (%)	0		
Sand (%)	37.5		
Gravel (%)	62.5		
Cobble (%)	0		
Boulder (%)	0		
Bedrock (%)	0		

Total Particles = 40 (need at least 60).

Active Riffle XS 5

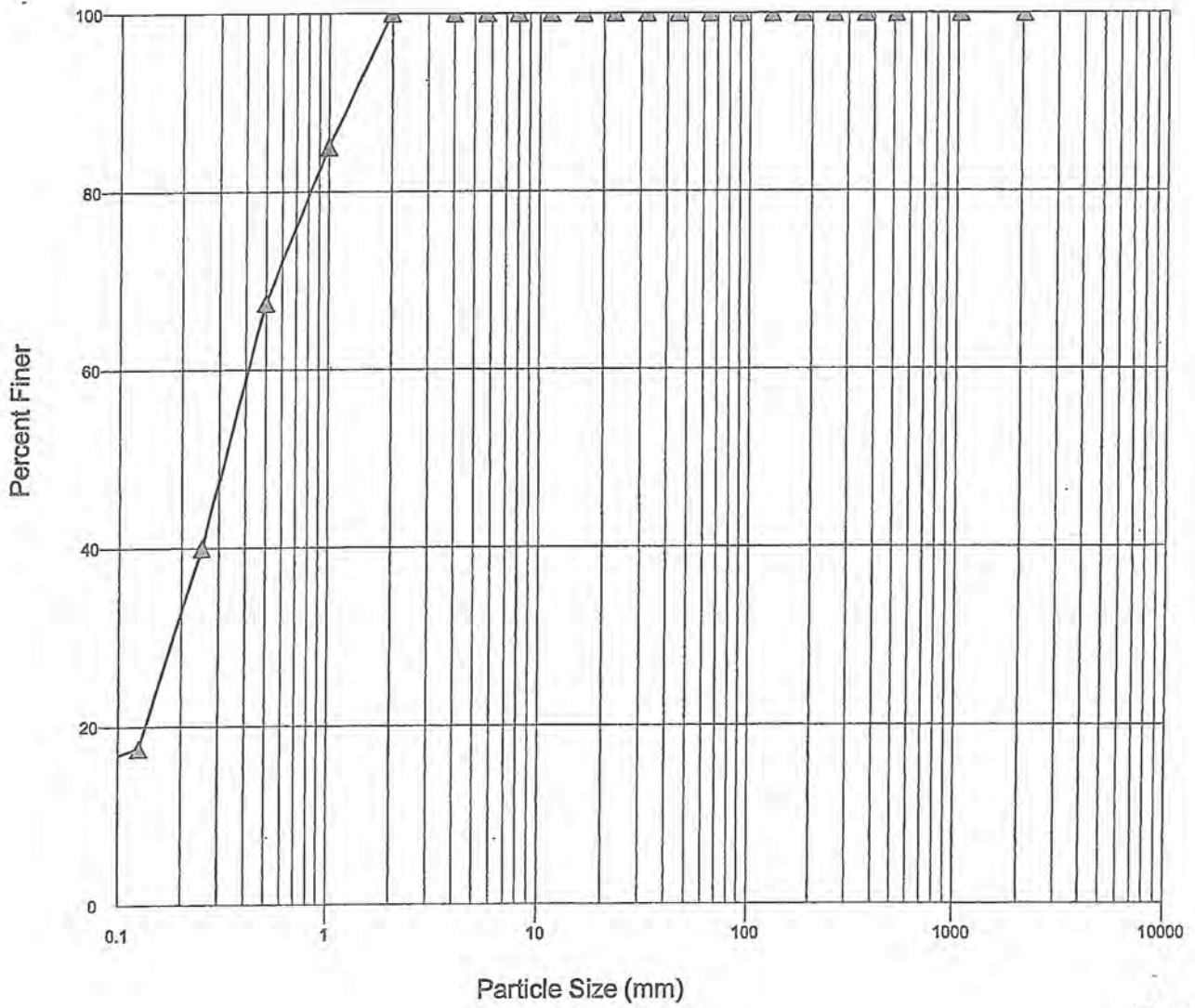

RIVERMORPH PARTICLE SUMMARY

 River Name: UT to Muddy Creek
 Reach Name: Existing Conditions
 Sample Name: Active Riffle XS 5
 Survey Date: 11/30/2011

Size (mm)	TOT #	ITEM %	CUM %
0 - 0.062	0	0.00	0.00
0.062 - 0.125	7	17.50	17.50
0.125 - 0.25	9	22.50	40.00
0.25 - 0.50	11	27.50	67.50
0.50 - 1.0	7	17.50	85.00
1.0 - 2.0	6	15.00	100.00
2.0 - 4.0	0	0.00	100.00
4.0 - 5.7	0	0.00	100.00
5.7 - 8.0	0	0.00	100.00
8.0 - 11.3	0	0.00	100.00
11.3 - 16.0	0	0.00	100.00
16.0 - 22.6	0	0.00	100.00
22.6 - 32.0	0	0.00	100.00
32 - 45	0	0.00	100.00
45 - 64	0	0.00	100.00
64 - 90	0	0.00	100.00
90 - 128	0	0.00	100.00
128 - 180	0	0.00	100.00
180 - 256	0	0.00	100.00
256 - 362	0	0.00	100.00
362 - 512	0	0.00	100.00
512 - 1024	0	0.00	100.00
1024 - 2048	0	0.00	100.00
Bedrock	0	0.00	100.00
D16 (mm)	0.12		
D35 (mm)	0.22		
D50 (mm)	0.34		
D84 (mm)	0.97		
D95 (mm)	1.67		
D100 (mm)	2		
silt/clay (%)	0		
sand (%)	100		
Gravel (%)	0		
Cobble (%)	0		
Boulder (%)	0		
Bedrock (%)	0		

Total Particles = 40 (need at least 60).

Entrainment Calculation Form

Status: Existing Conditions
 Project: U-2707
 Date: 7/22/2011

Location: Forsythe Co.
 Reach: R1A, XS 3, Pebble Count Riffle 3
 Observers: EMP

Value	Variable	Definition		
Required Information for Entrainment Analysis				
2.7	D_{50} (mm)	D_{50} from Riffle (1) or Pavement (2)	Riffle	Select Sample
0.1	D_{50} (mm)	D_{50} from Bar Sample (1) or Subpavement (2)	Bar Sample	Type
6	D_L (mm)	Largest Particle from Bar Sample (1) or Pavement (2)	Bar Sample	Type
0.020	D_s (ft)	D_L (mm) / 304.8 (mm/ft)		
0.006	S (ft/ft)	Bankfull Water Surface Slope		
0.65	d (ft)	Bankfull Mean Depth		
8.93	A (ft ²)	Bankfull Cross Sectional Area		
14.85	W_p (ft)	Wetted Perimeter		
1.65	γ_s	Submerged Specific Weight of Sediment (1.65)		
62.4	γ (lbs/ft ³)	Density of Water (62.4)		
Calculation of Critical Dimensionless Shear Stress				
27.00	D_{50}/D_{50}	Range 3-7 Use Equation 1: $\tau_c = 0.0834(D_{50}/D_{50})^{-0.872}$		
2.22	D_L/D_{50}	Range 1.3-3.0 Use Equation 2: $\tau_c = 0.0384(D_L/D_{50})^{0.887}$		
0.019	τ_c	Critical Dimensionless Shear Stress	Equation Used:	2
Calculate Bankfull Mean Depth Required for Entrainment of Largest Particle				
0.102	d_r	Required Bankfull Mean Depth (ft) $d_r = \frac{\tau_c \gamma_s D_L}{S}$		
6.349	d_r/d	Stability: Stable Degrading		
Calculate Bankfull Water Surface Slope Required for Entrainment of Largest Particle				
0.001	S_r	Required Bankfull Water Surface Slope (ft/ft) $S_r = \frac{\tau_c \gamma_s D_L}{d}$		
6.349	S_r/S	Stability: Stable Degrading		
Sediment Transport Validation - Bankfull Shear Stress				
0.60	R	Hydraulic Radius (ft) $R = A/W_p$		
0.225	τ_b	Bankfull Shear Stress (lbs/ft ²) $\tau_b = \gamma R S$		
X	Y or N	Is the Bed Material Homogeneous? Determine from reach wide pebble count distribution (Use your best judgement). If homogeneous use "Leopold et. al" Curve Data, if heterogeneous use "Colorado" Curve Data.		
16	mm	Movable Particle Size (mm) At Bankfull Shear Stress predicted by the Leopold, Wolman, & Miller 1964 Power-trendline.		
0.085	lb/ft ²	Predicted Shear Stress (lbs/ft ²) Required To Move D_r predicted by the Leopold, Wolman, & Miller 1964 Power-trendline.		
N/A	mm	Movable Particle Size (mm) At Bankfull Shear Stress predicted by the Colorado Data Power-trendline.		
N/A	lb/ft ²	Predicted Shear Stress (lbs/ft ²) Required To Move D_r predicted by the Colorado Data Power-trendline.		

Taken from *The Reference Reach Field Book*, 2005 by Rosgen and Siver

Entrainment Calculation Form

Status: Proposed, iteration 1
 Project: U-270
 Date: 11/22/2011

Location: Forsythe Co.
 Reach: R1a, XS 3, Pebble Count Riffle 3
 Observer: JEMP

Value	Variable	Definition
Required Information (Per Entrainment 2005 and 1934)		
2/7	D_{50} (mm)	D_{50} from Riffle (1) or Pavement (2)
0/1	D_{50} (mm)	D_{50} from Bar Sample (1) or Subpavement (2)
6	D_i (mm)	Largest Particle from Bar Sample (1) or Pavement (2)
0.020	D_i (ft)	D_i (mm) / 304.8 (mm/ft)
0.008	S (ft/ft)	Bankfull Water Surface Slope
0.84	d (ft)	Bankfull Mean Depth
10	A (ft ²)	Bankfull Cross Sectional Area
12.39	W_p (ft)	Wetted Perimeter
1.65	γ_s	Submerged Specific Weight of Sediment (1.65)
62.4	γ (lbs./ft ³)	Density of Water (62.4)
Calculation of Critical Dimensionless Shear Stress		
27.00	D_{30}/D_{50}	Range 3- Use Equation 1: $\tau_{c1} = 0.0834(D_{30}/D_{50})^{-0.872}$
2.22	D_i/D_{50}	Range 1.3-3.0 Use Equation 2: $\tau_{c2} = 0.0384(D_i/D_{50})^{-0.887}$
0.019	τ_{c1}	Critical Dimensionless Shear Stress Equation Used: 2
Calculate Bankfull Mean Depth Required for Entrainment of Largest Particle		
0.077	d_c	Required Bankfull Mean Depth (ft) $d_c = \frac{\tau_{c1} D_i}{S}$
10.940	d/d_c	Stability: Degrading
Calculate Bankfull Water Surface Slope Required for Entrainment of Largest Particle		
0.001	S_c	Required Bankfull Water Surface Slope (ft/ft) $S_c = \frac{\tau_{c1} D_i}{d}$
10.940	S/S_c	Stability: Degrading
Sediment Transport Validation (Bankfull Shear Stress)		
0.81	R	Hydraulic Radius (ft) $R = A/W_p$
0.403	τ_c	Bankfull Shear Stress (lbs./ft ²) $\tau_c = \gamma R S$
Y	Y or N	Is the Bed Material Homogeneous? Determine from reach wide pebble count distribution (Use your best judgement). If homogeneous use "Leopold et al" Curve Data, if heterogeneous use "Colorado" Curve Data.
30	mm	Movable Particle Size (mm) At Bankfull Shear Stress predicted by the Leopold, Wolman, & Miller 1964 Power-trendline.
0.085	lb./ft ²	Predicted Shear Stress (lbs./ft ²) Required To Move D_i predicted by the Leopold, Wolman, & Miller 1964 Power-trendline.
N/A	mm	Movable Particle Size (mm) At Bankfull Shear Stress predicted by the Colorado Data Power-trendline.
N/A	lb./ft ²	Predicted Shear Stress (lbs./ft ²) Required To Move D_i predicted by the Colorado Data Power-trendline.

*Taken from *The Reference Reach Field Book*, 2005 by Rosgen and Silvey

Entrainment Calculation Form

Status: Existing Conditions
 Project: U-270
 Date: 1/22/2011

Location: Forsythe Co.
 Reach: R1b, XS 5, Pebble Count Riffle 3
 Observers: EMP

Value	Variable	Definition		
Required Information for Entrainment Analysis				
2.7	D ₅₀ (mm)	D ₅₀ from Riffle (1) or Pavement (2)	Riffle	Select Sample
0.1	D ₅₀ (mm)	D ₅₀ from Bar Sample (1) or Subpavement (2)	Bar Sample	Type
6	D _i (mm)	Largest Particle from Bar Sample (1) or Pavement (2)	Bar Sample	
0.020	D _i (ft)	D _i (mm) / 304.8 (mm/ft)		
0.006	S (ft/ft)	Bankfull Water Surface Slope		
1.58	d (ft)	Bankfull Mean Depth		
14	A (ft ²)	Bankfull Cross Sectional Area		
10.56	W _w (ft)	Wetted Perimeter		
1.65	γ _s	Submerged Specific Weight of Sediment (1.65)		
62.4	γ (lbs/ft ³)	Density of Water (62.4)		

Calculation of Critical Dimensionless Shear Stress				
27.00	D ₅₀ /D ₅₀	Range 3-2	Use Equation 1: $\tau_{*c} = 0.0834(D_{50}/D_{50})^{-0.672}$	
2.22	D _i /D ₅₀	Range 1.3-3.0	Use Equation 2: $\tau_{*c} = 0.0384(D_i/D_{50})^{-0.887}$	
0.019	τ _{*c}	Critical Dimensionless Shear Stress	Equation Used:	2

Calculate Bankfull Mean Depth Required for Entrainment of Largest Particle				
0.102	d _r	Required Bankfull Mean Depth (ft)	$d_r = \frac{\tau_{*c} \gamma_s D_i}{S}$	
15.433	d/d _r	Stability:	Stable Degrading	

Calculate Bankfull Water Surface Slope Required for Entrainment of Largest Particle				
0.000	S _r	Required Bankfull Water Surface Slope (ft/ft)	$S_r = \frac{\tau_{*c} \gamma_s D_i}{d}$	
15.433	S/S _r	Stability:	Stable Degrading	

Sediment Transport Calculation - Bankfull Shear Stress				
1.33	R	Hydraulic Radius (ft)	$R = \frac{A}{W_p}$	
0.496	τ _c	Bankfull Shear Stress (lb/ft ²)	$\tau_c = \gamma R S$	
Y	Y or N	Is the Bed Material Homogeneous?		
Determine from reach wide pebble count distribution (Use your best judgement). If homogeneous use "Leopold et al" Curve Data, if heterogeneous use "Colorado" Curve Data.				
38	mm	Movable Particle Size (mm) At Bankfull Shear Stress predicted by the Leopold, Wolman, & Miller 1964 Power-trendline.		
0.085	lb/ft ²	Predicted Shear Stress (lbs/ft ²) Required To Move D _i predicted by the Leopold, Wolman, & Miller 1964 Power-trendline.		
N/A	mm	Movable Particle Size (mm) At Bankfull Shear Stress predicted by the Colorado Data Power-trendline.		
N/A	lb/ft ²	Predicted Shear Stress (lbs/ft ²) Required To Move D _i predicted by the Colorado Data Power-trendline.		

Taken from *The Reference Reach Field Book*, 2005 by Rosgen and Sivey

Entrainment Calculation Form

Status: Proposed, iteration 1
 Project: U-2707
 Date: 7/22/2011

Location: Forsythe Co.
 Reach: R1b, XS 5, Pebble Count Riffle 3
 Observers: EMP

Value	Variable	Definition	
Required Information for Entrainment Analysis			
2.7	D_{50} (mm)	D_{50} from Riffle (1) or Pavement (2)	Riffle <input type="checkbox"/> Select Sample
0.1	D'_{50} (mm)	D_{50} from Bar Sample (1) or Subpavement (2)	Bar Sample <input type="checkbox"/> Type
6	D_i (mm)	Largest Particle from Bar Sample (1) or Pavement (2)	Bar Sample <input type="checkbox"/>
0.020	D_i (ft)	D_i (mm) / 304.8 (mm/ft)	
0.0044	S (ft/ft)	Bankfull Water Surface Slope	
1.07	d (ft)	Bankfull Mean Depth	
15	A (ft ²)	Bankfull Cross Sectional Area	
14.52	W_p (ft)	Wetted Perimeter	
1.65	γ_s	Submerged Specific Weight of Sediment (1.65)	
62.4	γ (lbs/ft ³)	Density of Water (62.4)	
Calculation of Critical Dimensionless Shear Stress			
27.00	D_{50}/D'_{50}	Range 3- Use Equation 1: $\tau_{*c} = 0.0834(D_{50}/D'_{50})^{-0.872}$	
2.22	D_i/D_{50}	Range 1.3-3.0 Use Equation 2: $\tau_{*c} = 0.0384(D_i/D_{50})^{-0.687}$	
0.019	τ_{*c}	Critical Dimensionless Shear Stress	Equation Used: <input type="checkbox"/> 1 <input checked="" type="checkbox"/> 2
Calculate Bankfull Mean Depth Required for Entrainment of Largest Particle			
0.140	d_c	Required Bankfull Mean Depth (ft)	
		$d_c = \frac{\tau_{*c} \gamma_s D_i}{S}$	
7.665	d/d_c	Stability: <input type="checkbox"/> Stable <input checked="" type="checkbox"/> Degrading	
Calculate Bankfull Water Surface Slope Required for Entrainment of Largest Particle			
0.001	S_c	Required Bankfull Water Surface Slope (ft/ft)	
		$S_c = \frac{\tau_{*c} \gamma_s D_i}{d}$	
7.665	S/S_c	Stability: <input type="checkbox"/> Stable <input checked="" type="checkbox"/> Degrading	
Sediment Transport Variables - Bankfull Shear Stress			
1.03	R	Hydraulic Radius (ft) $R = A/W_p$	
0.284	τ_c	Bankfull Shear Stress (lb/ft ²) $\tau_c = \gamma R S$	
Y	Y or N	Is the Bed Material Homogeneous? Determine from reach wide pebble count distribution (Use your best judgement). If homogeneous use "Leopold et. al" Curve Data, if heterogeneous use "Colorado" Curve Data.	
21	mm	Movable Particle Size (mm) At Bankfull Shear Stress predicted by the Leopold, Wolman, & Miller 1964 Power-trendline.	
0.085	lb/ft ²	Predicted Shear Stress (lb/ft ²) Required To Move D_i predicted by the Leopold, Wolman, & Miller 1964 Power-trendline.	
N/A	mm	Movable Particle Size (mm) At Bankfull Shear Stress predicted by the Colorado Data Power-trendline.	
N/A	lb/ft ²	Predicted Shear Stress (lb/ft ²) Required To Move D_i predicted by the Colorado Data Power-trendline.	

Taken from The Reference Rates Field Book, 2005 by Rosgen and Silvey

Velocity Comparison Form

Project: U-2707
 Stream: UT to Muddy Creek
 Date: 8/16/2011

Location: Forsyth County, NC
 Reach: R1 Existing XS1
 Observers: Mulkey

Input Variables		Output Variables	
Bankfull X-Sec Area (Abkf)	9.86 sq ft	Bankfull Mean Depth (Dbkf)	0.85 ft
Bankfull Width (Wbkf)	11.58 ft	Wetted Perimeter (WP)	13.28 ft
D84 (Riffle or pavement)	1.82 mm	D84 (mm/304.8)	0.01 ft
Bankfull Slope (S)	0.0063 ft/ft	Hydraulic Radius (R)	0.74 ft
Gravitational Acceleration (g)	32.2 ft/sq sec	Dbkf/D84 (use D84 in ft)	142.35 ft/ft
Bankfull Maximum Depth	1.63 ft	R/D84 (use D84 in ft)	124.34 ft/ft

Dbkf/D84, u/u*, Mannings n	
u/u*	(Using Dbkf/D84 Red Book: p188; Blue p233) 13.5 ft/s/ft/s
Mannings n	(Red Book: p189; Blue :p236) 0.024
Velocity	(From Mannings' equation: $u=1.4865 * (R^{2/3})(S^{1/2})/n$) 4.04 ft/s

$u/u^* = 2.83 + 5.7 \log R/D84$	
u*	$u^* = (gRS)^{.5}$ 0.39 ft/s
Velocity:	$u = u^*(2.83 + 5.7 \log(R/D84))$ 5.74 ft/s

Mannings n by Stream Type	
Stream type	C6
Mannings n	(Red Book: p187; Blue :p237) 0.036
Velocity	(From Mannings' equation: $u=1.4865 * (R^{2/3})(S^{1/2})/n$) 2.77 ft/s

Continuity Equation	
Qbkf (cfs) original curve or stream gage hydraulic geometry	53 cfs
Velocity (u=Q/A) or from stream gage hydraulic geometry	5.38 ft/s

Sandbed stream

Dr. Richard Hey Method	
Coefficient a	$a = 11(R/d_{max})^{-0.314}$ 14.2
Friction Factor - f	$1/f^{1/2} = 2.03 \log (aR/3.5D84)$ 0.033
Velocity	(From D'Arcy Weisbach equation: $u=(8^*g^*R S/f)^{1/2}$) 6.03 ft/s

Velocity Comparison Form

Project: U-2707
 Stream: UT to Muddy Creek
 Date: 8/16/2011

Location: Forsyth County, NC
 Reach: R1 Existing XS3
 Observers: Mulkey

Input Variables		Output Variables	
Bankfull X-Sec Area (Abkf)	8.93 sq ft	Bankfull Mean Depth (Dbkf)	0.66 ft
Bankfull Width (Wbkf)	13.66 ft	Wetted Perimeter (WP)	14.96 ft
D84 (Riffle or pavement)	4.867 mm	D84 (mm/304.8)	0.02 ft
Bankfull Slope (S)	0.0063 ft/ft	Hydraulic Radius (R)	0.60 ft
Gravitational Acceleration (g)	32.2 ft/sq sec	Dbkf/D84 (use D84 in ft)	40.54 ft/ft
Bankfull Maximum Depth	1.68 ft	R/D84 (use D84 in ft)	37.23 ft/ft

Dbkf/D84, u/u*, Mannings n	
u/u* (Using Dbkf/D84 Red Book: p188; Blue p233)	11.2 ft/s/ft/s
Mannings n (Red Book: p189; Blue :p236)	0.026
Velocity (From Mannings' equation: $u=1.4865 * (R^{2/3})(S^{1/2})/n$)	3.22 ft/s

u/u* = 2.83 + 5.7 log R/D84	
u*	$u^* = (gRS)^{.5}$ 0.35 ft/s
Velocity:	$u = u^*(2.83 + 5.7 \log(R/D84))$ 4.11 ft/s

Mannings n by Stream Type	
Stream type	C5
Mannings n (Red Book: p187; Blue :p237)	0.035
Velocity (From Mannings' equation: $u=1.4865 * (R^{2/3})(S^{1/2})/n$)	2.39 ft/s

Continuity Equation	
Qbkf (cfs) original curve or stream gage hydraulic geometry	53 cfs
Velocity (u=Q/A) or from stream gage hydraulic geometry	5.94 ft/s

Sandbed stream

Dr. Richard Hey Method	
Coefficient a	$a = 11(R/d_{max})^{-0.314}$ 15.4
Friction Factor - f	$1/f^{1/2} = 2.03 \log (aR/3.5D84)$ 0.050
Velocity (From D'Arcy Weisbach equation: $u=(8^*g^*R S/f)^{1/2}$)	4.43 ft/s

Velocity Comparison Form

Project: U-2707
 Stream: UT to Muddy Creek
 Date: 8/16/2011

Location: Forsyth County, NC
 Reach: R1 Existing XS5
 Observers: Mulkey

Input Variables		Output Variables	
Bankfull X-Sec Area (Abkf)	14 sq ft	Bankfull Mean Depth (Dbkf)	1.58 ft
Bankfull Width (Wbkf)	8.86 ft	Wetted Perimeter (WP)	12.02 ft
D84 (Riffle or pavement)	0.87 mm	D84 (mm/304.8)	0.00 ft
Bankfull Slope (S)	0.0063 ft/ft	Hydraulic Radius (R)	1.16 ft
Gravitational Acceleration (g)	32.2 ft/sq sec	Dbkf/D84 (use D84 in ft)	496.48 ft/ft
Bankfull Maximum Depth	2.37 ft	R/D84 (use D84 in ft)	365.99 ft/ft

Dbkf/D84, u/u*, Mannings n	
u/u* (Using Dbkf/D84 Red Book: p188; Blue: p233)	ft/s/ft/s
Mannings n (Red Book: p189; Blue :p236)	
Velocity (From Mannings' equation: $u=1.4865 * (R^{2/3})(S^{1/2})/n$)	#DIV/0! ft/s

UNABLE TO CALCULATE DUE TO LOW D84

u/u*=2.83+5.7logR/D84	
u* $u^* = (gRS)^{.5}$	0.49 ft/s
Velocity: $u = u^*(2.83+5.7log(R/D84))$	8.49 ft/s

Mannings n by StreamType	
Stream type	C5
Mannings n (Red Book: p187; Blue :p237)	0.035
Velocity (From Mannings' equation: $u=1.4865 * (R^{2/3})(S^{1/2})/n$)	3.74 ft/s

Continuity Equation	
Q/bkf (cfs) original curve or stream gage hydraulic geometry	53 cfs
Velocity (u=Q/A) or from stream gage hydraulic geometry	3.79 ft/s

Sandbed stream

Dr. Richard Hay Method	
Coefficient a $a = 11(R/d_{max})^{-0.314}$	13.9
Friction Factor - f $1/f^{1/2} = 2.03 \log (aR/3.5D84)$	0.024
Velocity (From D'Arcy Weisbach equation: $u=(8*g*R S/f)^{1/2}$)	8.84 ft/s

Velocity Comparison Form

Project: U-2707
 Stream: UT to Muddy Creek
 Date: 8/16/2011

Location: Forsyth County, NC
 Reach: Proposed R1a
 Observers: Mulkey

Based on Characteristics of Riffle Number 3

Input Variables		Output Variables	
Bankfull X-Sec Area (Abkf)	10 sq ft	Bankfull Mean Depth (Dbkf)	0.84 ft
Bankfull Width (Wbkf)	12 ft	Wetted Perimeter (WP)	13.68 ft
D84 (Riffle or pavement)	4.87 mm	D84 (mm/304.8)	0.02 ft
Bankfull Slope (S)	0.0075 ft/ft	Hydraulic Radius (R)	0.73 ft
Gravitational Acceleration (g)	32.2 ft/sq sec	Dbkf/D84 (use D84 in ft)	52.57 ft/ft
Bankfull Maximum Depth	1.4 ft	R/D84 (use D84 in ft)	45.75 ft/ft

Dbkf/D84, u/u*, Mannings n	
u/u*	(Using Dbkf/D84 Red Book: p188; Blue p233) 12 ft/s/ft/s
Mannings n	(Red Book: p189; Blue p236) 0.025
Velocity	(From Mannings' equation: $u=1.4865 * (R^{2/3})(S^{1/2})/n$) 4.18 ft/s

u/u* = 2.83 + 5.7 log R/D84	
u*	$u^* = (gRS)^{.5}$ 0.42 ft/s
Velocity:	$u = u^*(2.83 + 5.7 \log(R/D84))$ 5.17 ft/s

Mannings n by StreamType	
Stream type	C5
Mannings n	(Red Book: p187; Blue p237) 0.035
Velocity	(From Mannings' equation: $u=1.4865 * (R^{2/3})(S^{1/2})/n$) 2.98 ft/s

Continuity Equation	
Qbkf (cfs) original curve or stream gage hydraulic geometry	53 cfs
Velocity (u=Q/A) or from stream gage hydraulic geometry	5.30 ft/s

Sandbed stream

Dr. Richard Hey Method	
Coefficient a	$a = 11(R/d_{max})^{-.0314}$ 13.6
Friction Factor - f	$1/f^{1/2} = 2.03 \log (aR/3.5D84)$ 0.048
Velocity	(From D'Arcy Weisbach equation: $u=(8*g*R S/f)^{1/2}$) 5.43 ft/s

Velocity Comparison Form

Project: U-2707
 Stream: UT to Muddy Creek
 Date: 8/16/2011

Location: Forsyth County, NC
 Reach: Proposed R1b
 Observers: Mulkey

Based on Characteristics of Riffle Number 5

Input Variables		Output Variables	
Bankfull X-Sec Area (Abkf)	15 sq ft	Bankfull Mean Depth (Dbkf)	1.07 ft
Bankfull Width (Wbkf)	14 ft	Wetted Perimeter (WP)	16.14 ft
D84 (Riffle or pavement)	0.97 mm	D84 (mm/304.8)	0.00 ft
Bankfull Slope (S)	0.0044 ft/ft	Hydraulic Radius (R)	0.93 ft
Gravitational Acceleration (g)	32.2 ft/sq.sec	Dbkf/D84 (use D84 in ft)	336.22 ft/ft
Bankfull Maximum Depth	1.76 ft	R/D84 (use D84 in ft)	292.03 ft/ft

Dbkf/D84, u/u*, Mannings n		
u/u*	(Using Dbkf/D84 Red Book: p188; Blue p233)	ft/s/ft/s
Mannings n	(Red Book: p189; Blue p236)	
Velocity	(From Mannings' equation: $u=1.4865 * (R^{2/3})(S^{1/2})/n$)	#DIV/0! ft/s

UNABLE TO CALCULATE DUE TO LOW D84

u/u* = 2.83 + 5.7 log R/D84		
u*	$u^* = (gRS)^{.5}$	0.36 ft/s
Velocity:	$u = u^*(2.83 + 5.7 \log(R/D84))$	6.13 ft/s

Mannings n by Stream Type		
Stream type		C5
Mannings n	(Red Book: p187; Blue p237)	0.035
Velocity	(From Mannings' equation: $u=1.4865 * (R^{2/3})(S^{1/2})/n$)	2.68 ft/s

Continuity Equation		
Qbkf (cfs) original curve or stream gage hydraulic geometry		53 cfs
Velocity (u=Q/A) or from stream gage hydraulic geometry		3.53 ft/s

Sandbed stream

Dr. Richard Hay Method		
Coefficient a	$a = 11(R/d_{max})^{.314}$	13.6
Friction Factor - f	$1/f^{.1/2} = 2.03 \log (aR/3.5D84)$	0.026
Velocity	(From D'Arcy Weisbach equation: $u=(8 \cdot g \cdot R \cdot S/f)^{.1/2}$)	6.36 ft/s

U2707 R1 XS 1 Design

- (C) XS1 Design Mbk F = 12
- ◆ Bankfull Indicators Dbk F = 8.9
- ▽ Water Surface Points Δ XS1 Riffle Δbk F = 10.1

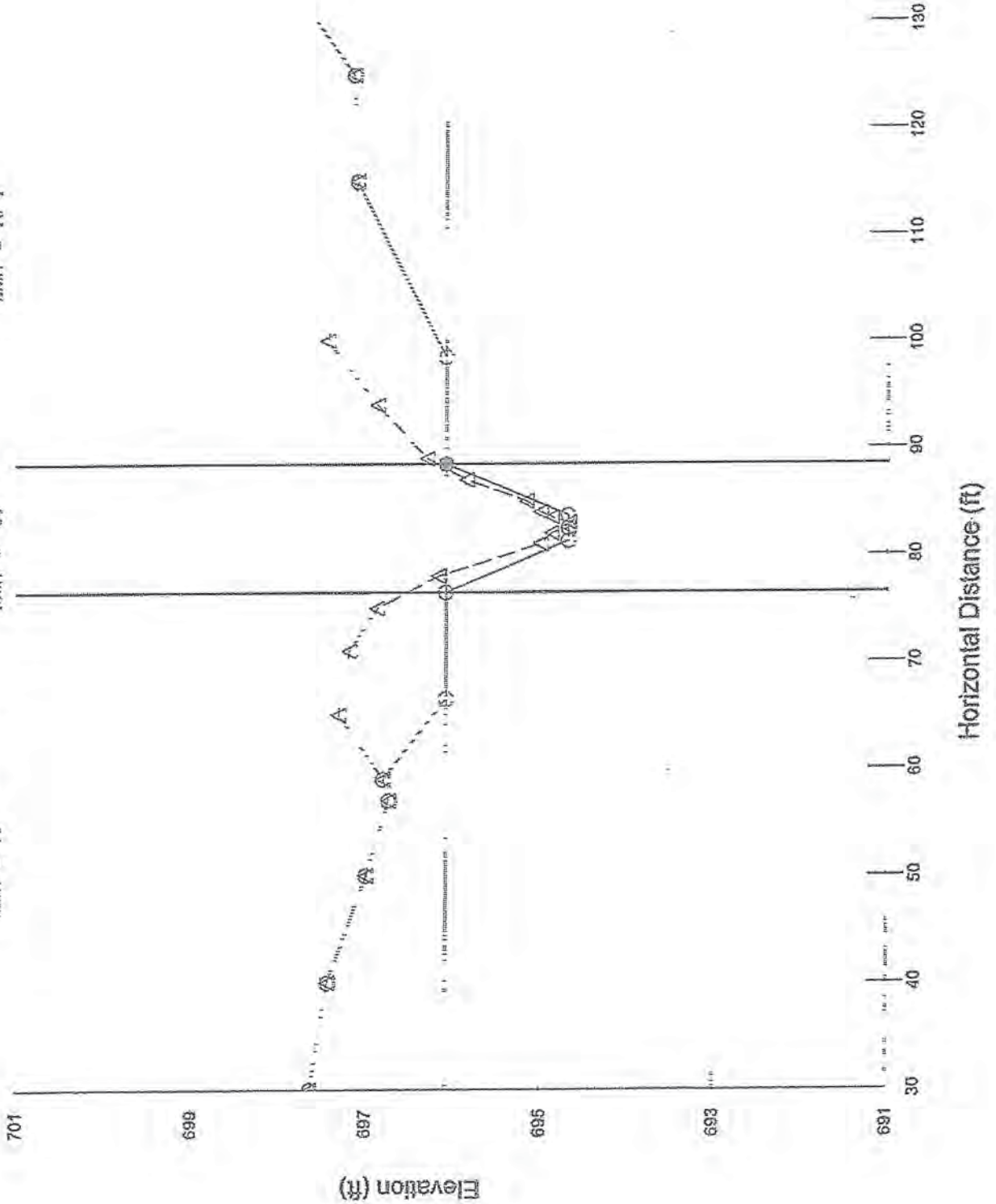

U2707 R1 XS3 Design

- () XS3 Design
- Bankfull Indicators
- Water Surface Points
- XS3 Riffle
- Bankfull = 12
- Bankfull = 84
- Bankfull = 10

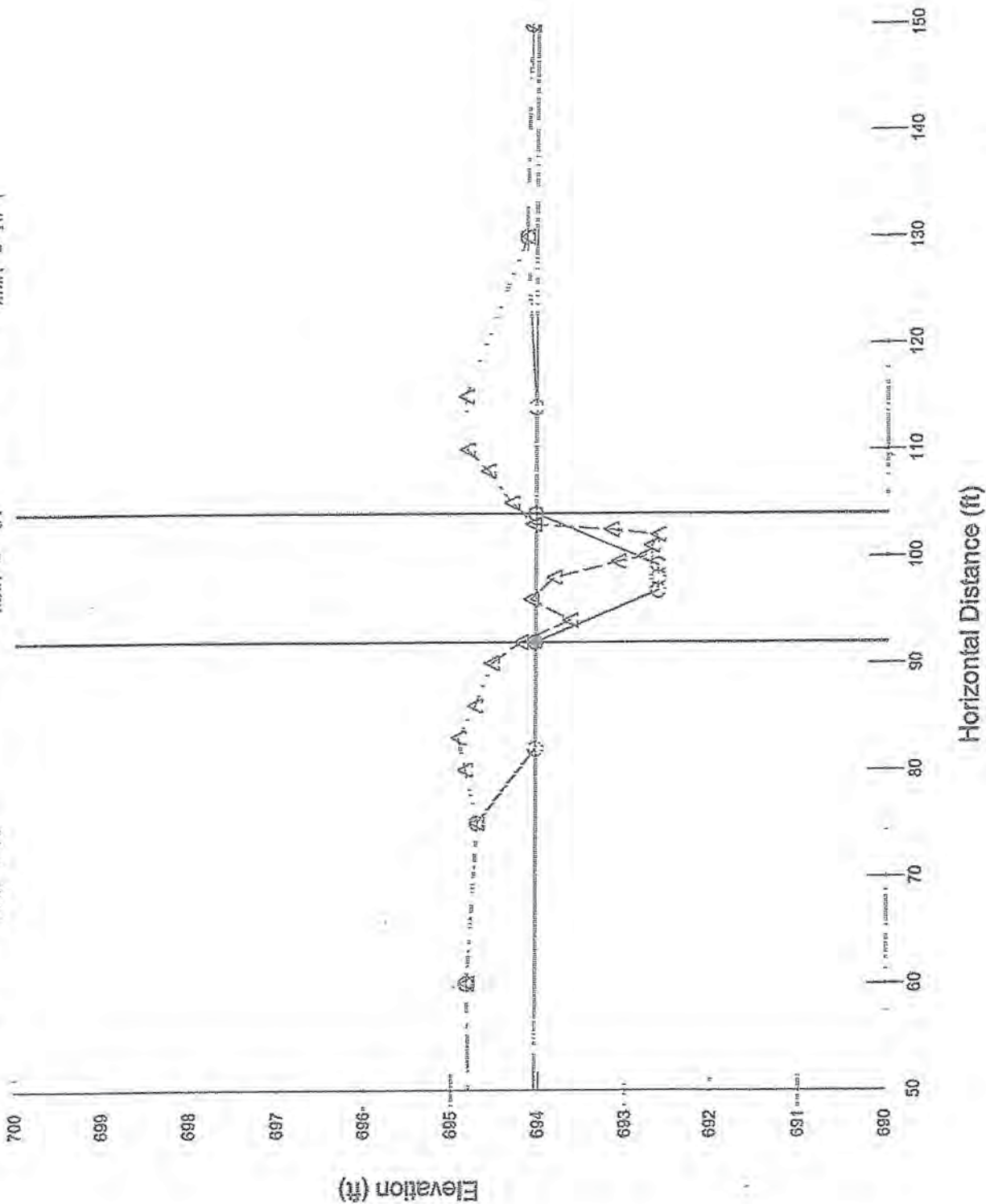

U2707 R1 XS5 Design

() XS5 Design Wbk f = 14 Δ XS5 Riffle Abk f = 14.9
 ◆ Bankfull Indicators ▽ Water Surface Points Dbk f = 1.07

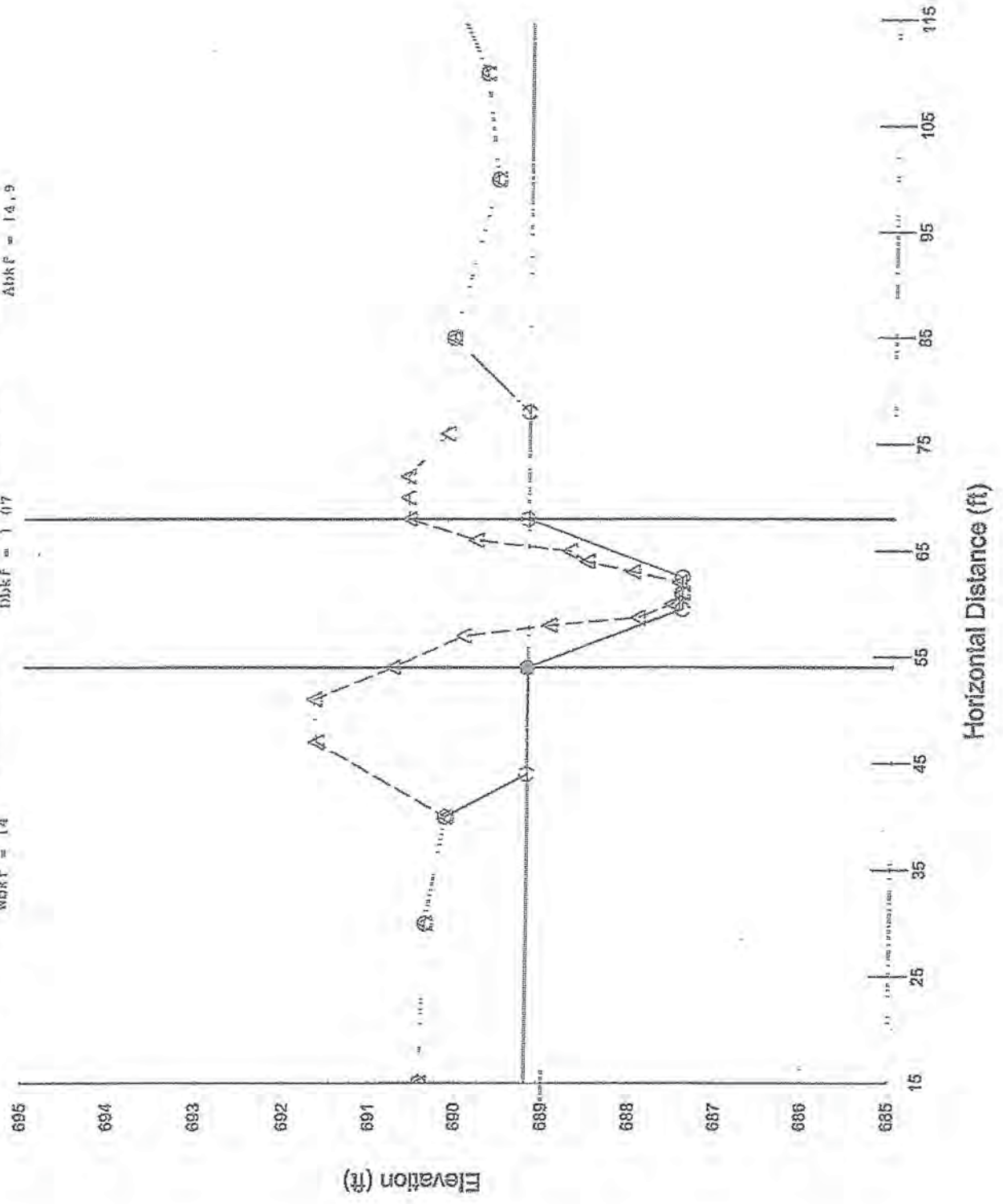

U2707 R1 XS6 Design

- (^) XS6 Design Wbk F = 14
- ◆ Bankfull Indicators Wbk F = 1.07
- ▽ Water Surface Points Wbk F = 1.15
- △ XS6 Rimline Wbk F = 1.15

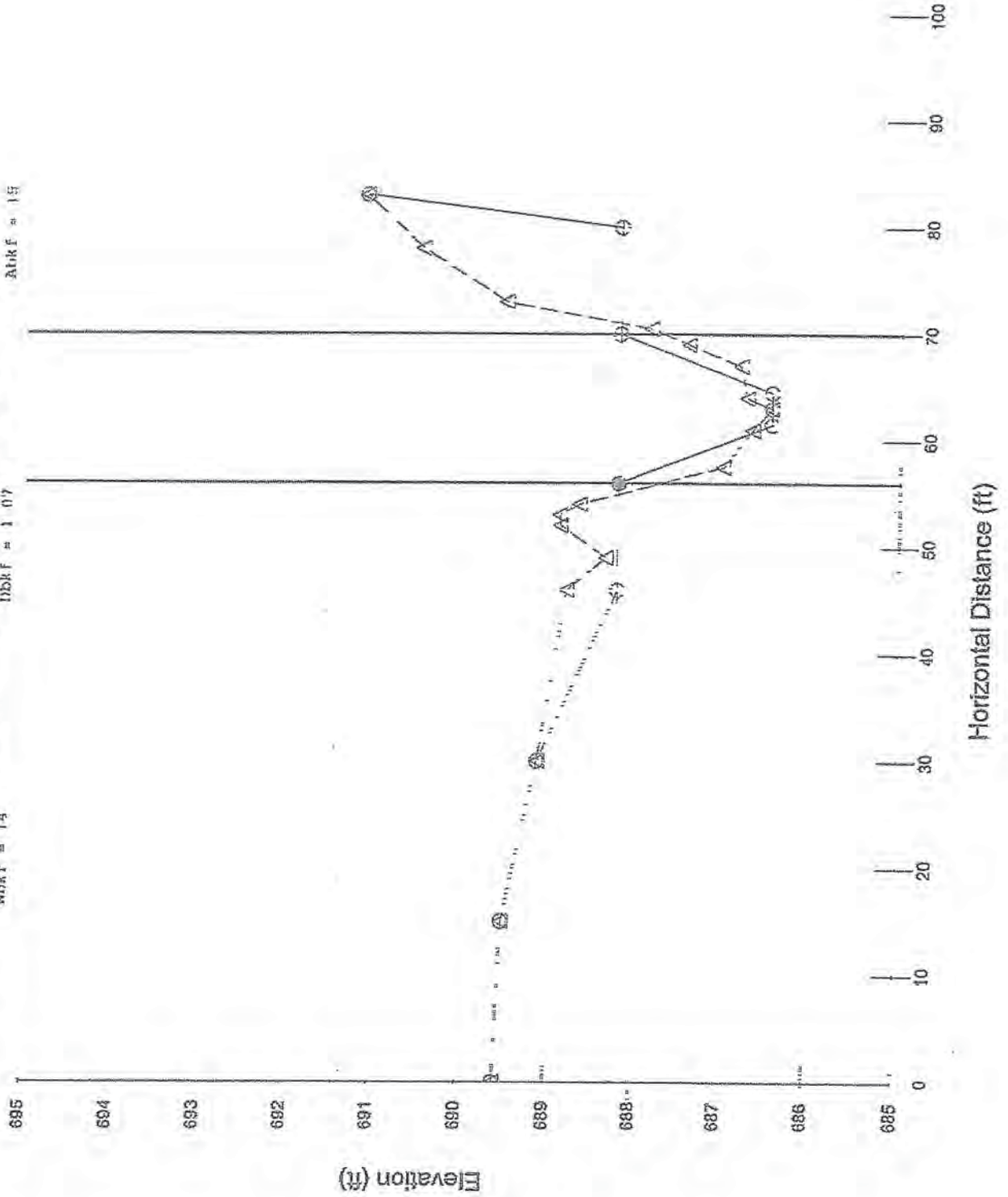

FOOTWAY DESIGN
WORKSHEET

INCOMPLETE PLANS
DO NOT BE USED FOR
CONSTRUCTION
PRELIMINARY PLANS
DO NOT BE USED FOR
CONSTRUCTION

RECEIVED
MAY 09 2012
RALEIGH REGULATORY
FIELD OFFICE

MORPHOLOGICAL MEASUREMENTS TABLE

UT TO MUDDY CREEK
-R1- Sta. 0+00.00 to Sta. 9+20.00

Variables	Existing Channel Sta. 0+00.00 to 9+20.00	Proposed Reach Sta. 0+00.00 to 9+20.00	USGS Station	Reference Reach Sta. 0+00.00 to 9+20.00
1. Stream type	0.88 SD III(28) RCH(S)	0.88 SD III(28) RCH(S)		0.88 SD III(28) RCH(S)
2. Drainage area	Mean: 11.76	Mean: 12.00		Mean: 15.48
3. Bankfull width	Range: 8.05-14.80	Range: 6.83		Range: 11.90-17.70
4. Bankfull mean depth	Mean: 3.12	Mean: 1.64		Mean: 1.23
5. Width/depth ratio	Range: 3.55-17.48	Range: 10.00		Range: 11.42-14.37
6. Bankfull cross-sectional area	Mean: 10.77	Mean: 5.30		Mean: 21.33
7. Bankfull mean velocity	Range: 5.33-14.00	Range: 5.30		Range: 20.00-22.70
8. Bankfull discharge of 5	Mean: 53	Mean: 53		Mean: 248
9. Bankfull discharge of 5	Range: 1.80	Range: 1.40		Range: 1.80
10. Bankfull max depth	Mean: 0.95-2.37	Mean: 1.40-1.40		Mean: 2.80-2.22
11. Width of floodprone area	Mean: 10.67	Mean: 10.000		Range: 11.25
12. Width of floodprone area	Range: 4.89-18.00	Range: 2.22		Range: 18.20-18.60
13. Entrenchment ratio	Mean: 1.41	Mean: 2.22		Mean: 1.30
14. Meander length	Range: 3.25-17.68	Range: 85.10		Mean: 80.30
15. Ratio of meander length to bankfull width	Mean: 5.087	Mean: 80.00-102.00		Range: 64.32-114.00
16. Radius of curvature	Range: 4.48	Mean: 1.31		Mean: 5.93
17. Ratio of radius of curvature to bankfull width	Mean: 2.19	Range: 6.60-8.90		Mean: 16.44
18. Bankfull width ratio	Range: 1.00-1.32	Mean: 2.80-3.00		Range: 4.05-7.37
19. Sinuosity (stream length/valley length)	Mean: 1.06	Mean: 1.12		Mean: 1.18
20. Average slope	Range: 0.00000	Mean: 0.00055		Range: 0.01230
21. Pool slope	Mean: 0.00002	Mean: 0.0000		Mean: 0.00072
22. Ratio of pool slope to average slope	Range: 0.00000-0.00135	Mean: 0.0000-0.0030		Range: 0.00020
23. Maximum pool depth	Mean: 0.05	Mean: 0.25		Mean: 0.25
24. Ratio of pool depth to average bankfull depth	Range: 0.03-1.00	Mean: 1.23		Range: 0.20-0.31
25. Pool width	Mean: 1.94	Mean: 1.83		Mean: 2.05-2.89
26. Ratio of pool width to bankfull width	Range: 1.40-2.47	Mean: 2.21		Range: 2.22
27. Pool to pool spacing	Mean: 2.1	Mean: 12.00		Mean: 2.74-2.83
28. Ratio of pool to pool spacing to bankfull width	Range: 1.95-3.45	Mean: 10		Mean: 16.10
29. Ratio of lowest bank height to bankfull height (or max bankfull depth)	Mean: 1.69	Mean: 3.25-3.17		Range: 12.60-20.00
	Mean: 1.63	Mean: 5.50		Mean: 1.93
	Range: 0.81-1.25	Mean: 3.50		Range: 0.81-1.29
	Mean: 2.34-7.863	Mean: 4.66		Mean: 3.573-6.822
	Range: 1.53	Mean: 10		Mean: 3.36
	Mean: 2.58-6.92	Mean: 1.0		Mean: 2.31-4.11
	Mean: N/A	Mean: N/A		Mean: 3.06
	Range: N/A	Range: N/A		Range: 1.0-1.5

INCOMPLETE PLANS
FOR PRELIMINARY PLANS
DO NOT USE FOR CONSTRUCTION

MORPHOLOGICAL MEASUREMENTS TABLE

UT TO MUDDY CREEK
-RI- Sta. 9+20.00 to Sta. 18+00.00

Variables	Existing Channel C/S	Proposed Reach C/S	USGS Station	Terrestrial Reach C/S
1. Stream type	0.49 SG M(1.36 ACRES)	0.49 SG M(1.36 ACRES)		3.55 SG M(1.36 ACRES)
2. Drainage area	Mean: 1.36	Mean: 1.36		Mean: 1.48
3. Bankfull width	Range: 0.05-4.00	Range: 1.07		Range: 1.90-7.70
4. Bankfull mean depth	Mean: 0.12	Mean: 0.30		Mean: 0.29
5. Width/depth ratio	Range: 15.56	Range: 1.66		Range: 11.42-14.37
6. Bankfull cross-sectional area	Mean: 10.77	Mean: 5.00		Mean: 21.33
7. Bankfull mean velocity	Range: 5.93-14.00	Range: 3.53		Range: 20.00-20.75
8. Bankfull discharge of S	Mean: 5.10	Mean: 5.33		Mean: 2.90
9. Bankfull max depth	Mean: 5.5	Mean: 5.5		Mean: 5.0
10. Width of floodprone area	Range: 1.50	Range: 1.5		Range: 1.50-2.12
11. Entrenchment ratio	Mean: 18.67	Mean: 20.00		Mean: 11.25
12. Meander length	Range: 48.69-100.00	Range: 2.2		Range: 162.00-166.00
13. Ratio of meander length to bankfull width	Mean: 3.29-17.82	Mean: 57.40		Mean: 11.10
14. Radius of curvature	Mean: 31.09-73.07	Mean: 91.07-20.51		Mean: 100.85-144.5
15. Ratio of radius of curvature to bankfull width	Mean: 4.40	Mean: 6.96		Mean: 64.32-110.0
16. Belt width	Range: 2.47-6.43	Mean: 33.80		Mean: 4.06-7.37
17. Meander width ratio	Mean: 22.22	Mean: 28.00-49.00		Mean: 18.44
18. Stream length/valley length	Range: 1.01-32.09	Mean: 2.42		Mean: 11.75-25.30
19. Valley slope	Mean: 1.96	Mean: 2.0-1.5		Mean: 1.49
20. Average slope	Range: 0.88-2.90	Mean: 23.20		Range: 0.76-1.93
21. Pool slope	Mean: 6.38	Mean: 12.00-4.00		Mean: 3.92
22. Ratio of pool slope to average slope	Range: 1.20-14.40	Mean: 0.66		Range: 1.54-54.25
23. Maximum pool depth	Mean: 0.56	Mean: 0.66		Mean: 2.06
24. Ratio of pool depth to average bankfull depth	Range: 0.11-1.27	Mean: 1.45		Range: 0.81-3.51
25. Pool width	Mean: 1.06	Mean: 0.00630		Mean: 1.41
26. Ratio of pool width to bankfull width	Range: 0.00675	Mean: 0.00630		Mean: 3.01230
27. Pool to pool spacing	Mean: 0.00632	Mean: 0.0044		Mean: 5.00672
28. Ratio of lowest bank height to bankfull depth	Range: 0.00616	Mean: 0.0017		Mean: 0.00291
29. Ratio of lowest bank height to bankfull depth (or max bankfull depth)	Mean: 0.00001-0.0136	Range: 0.0000-0.00130		Mean: 0.00175-0.00257
30. Average slope	Mean: 0.56	Mean: 0.27		Mean: 0.23
31. Pool slope	Range: 0.15-1.80	Range: 0.25-0.30		Range: 0.20-0.31
32. Maximum pool depth	Mean: 1.94	Mean: 2.40		Mean: 2.81
33. Ratio of pool depth to average bankfull depth	Range: 1.40-2.47	Range: 2.40-2.40		Range: 2.05-2.89
34. Pool width	Mean: 1.95-3.45	Mean: 4.00		Mean: 2.22
35. Ratio of pool width to bankfull width	Range: 1.03	Range: 1.03		Mean: 16.30
36. Ratio of pool width to bankfull width	Mean: 3.01-1.25	Mean: 56.20		Range: 12.60-30.00
37. Pool to pool spacing	Mean: 6.22	Mean: 50.00-7.00		Mean: 1.95
38. Ratio of pool to pool spacing to bankfull width	Range: 3.34-76.63	Mean: 4.01		Range: 6.81-1.29
39. Ratio of pool to pool spacing to bankfull width	Mean: 5.39	Mean: 3.57-5.37		Range: 3.573-68.22
40. Ratio of lowest bank height to bankfull depth	Mean: 2.90-6.92	Mean: 1.74		Mean: 3.36
41. Ratio of lowest bank height to bankfull depth (or max bankfull depth)	Mean: 1.74	Mean: 1.0		Range: 2.31-4.11
42. Ratio of lowest bank height to bankfull depth (or max bankfull depth)	Range: N/A	Range: N/A		Mean: 1.06
43. Ratio of lowest bank height to bankfull depth (or max bankfull depth)				Range: 1.0-1.5

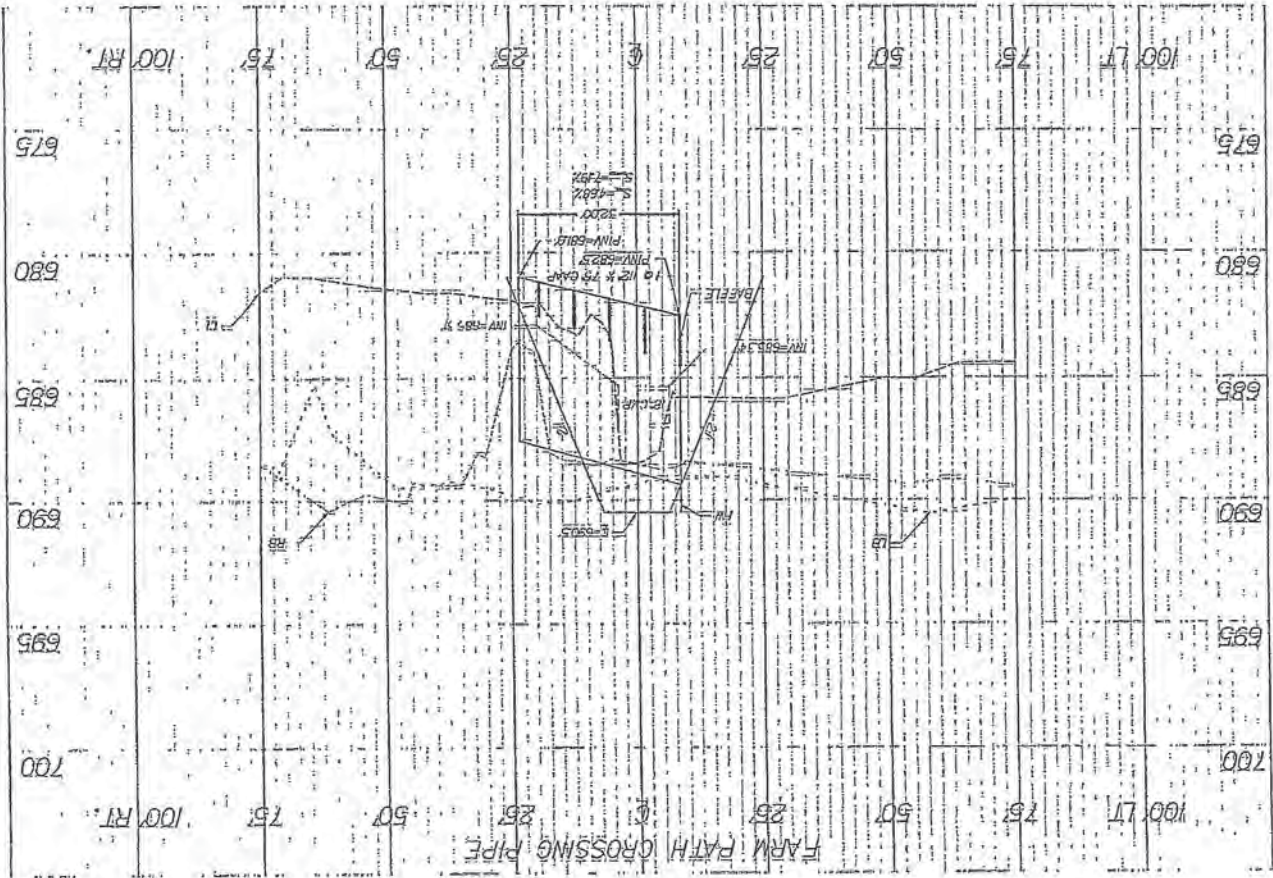

PIPE DATA SHEET

Date: 12/1/2011
 Project Number: 2003177.01
 ID. No. U-2707
 County: Forsyth
 Designed By: EMP
 Checked By: JKS
 Sheet 1 of 5

Plan Summary Data

Drainage Area: 1.13 sq. mi.
 Design Freq.: 2 YR
 Design Disch.: 172 cfs
 Design H.W. Elev.: 688.98
 Bankfull Disch.: N/A
 Bankfull H.W. Elev.: N/A
 Overlapping Freq.: N/A
 Overlapping Disch.: N/A
 Overlapping Elev.: N/A

Station: 90+
 Skew: N/A
 Size/Type Pipe: 1 @ 112x75 CAAP
 Type Entrance: L-R headwall
 Direction of Flow: USGS
 Hydraulic Method: USGS
 H.W. Control Elevation: 689.5
 Invert Elev.: 689.5

PIPE CULVERT ANALYSIS (English)

top=0.12, cnp=.024
 n=0.024

Channel Specs.	Slope:	LT Side Slope	RT Side Slope	Remarks
Base=	n=			
Channel Specs.	Slope:	LT Side Slope	RT Side Slope	Remarks
Outlet Control				
H.W.	ELEV.			

Size	#	FREQ	TW	O	Nat	Allow	H.W.	H.W/D	H.W (ft)	Inlet Control	IC	d	d	(d+D)/2	h _c	H	L	So	ELEV.	Remarks
67.25	1	5 YR	2.9	0.19			5.00	0.8	8.41		0.024	3.66	4.63	4.63	1.170	2.30	7.15	692.91		INLET CONTROL
67.25	1	2 YR	2.1	0.12			5.00	0.8	4.48		0.024	3.66	4.63	4.63	1.170	2.30	3.50	688.98		INLET CONTROL

**Hydraulics takes into account pipe is 112x75 CAAP with baffles reducing pipe size to an equivalent 87x63 CAAP
 **Inlet Invert Elevation based on invert of first baffle, outlet invert elevation based on 1.2 foot buried
 **HW Control Elevation equals 1 foot below shoulder
 **Discharges based on USGS Rural Regression Equation with a drainage area of 1.13 sq mi

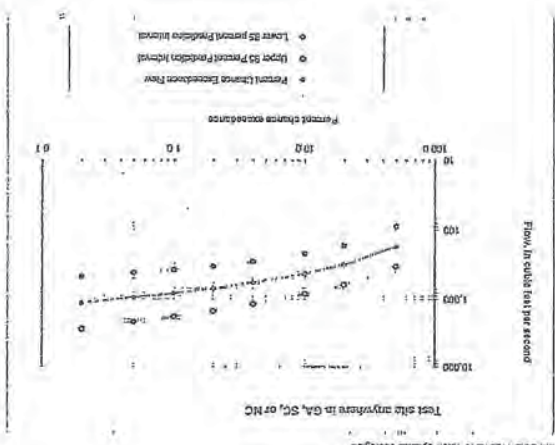

Flow, in cubic feet per second	Return (Lower) Exceedance Flow	Lower 50 Percent Prediction Interval	Lower 55 Percent Prediction Interval
10,000	10.0	10.0	10.0
20,000	15.0	12.0	13.0
30,000	20.0	15.0	17.0
40,000	25.0	18.0	21.0
50,000	30.0	22.0	25.0
60,000	35.0	26.0	29.0
70,000	40.0	30.0	33.0
80,000	45.0	34.0	37.0
90,000	50.0	38.0	41.0
100,000	55.0	42.0	45.0

Test site anywhere in GA, SC, or NC

DRAINAGE AREA WITHIN APPLICABLE LIMITS

Sum of region percentages

Percent of basin in Hydrologic Region 1

Percent of basin in Hydrologic Region 2

Percent of basin in Hydrologic Region 3

Percent of basin in Hydrologic Region 4

Percent of basin in Hydrologic Region 5

Percent of basin in Hydrologic Region 6

Percent of basin in Hydrologic Region 7

Percent of basin in Hydrologic Region 8

Percent of basin in Hydrologic Region 9

Percent of basin in Hydrologic Region 10

Percent of basin in Hydrologic Region 11

Percent of basin in Hydrologic Region 12

Percent of basin in Hydrologic Region 13

Percent of basin in Hydrologic Region 14

Percent of basin in Hydrologic Region 15

Percent of basin in Hydrologic Region 16

Percent of basin in Hydrologic Region 17

Percent of basin in Hydrologic Region 18

Percent of basin in Hydrologic Region 19

Percent of basin in Hydrologic Region 20

Percent of basin in Hydrologic Region 21

Percent of basin in Hydrologic Region 22

Percent of basin in Hydrologic Region 23

Percent of basin in Hydrologic Region 24

Percent of basin in Hydrologic Region 25

Percent of basin in Hydrologic Region 26

Percent of basin in Hydrologic Region 27

Percent of basin in Hydrologic Region 28

Percent of basin in Hydrologic Region 29

Percent of basin in Hydrologic Region 30

Percent of basin in Hydrologic Region 31

Percent of basin in Hydrologic Region 32

Percent of basin in Hydrologic Region 33

Percent of basin in Hydrologic Region 34

Percent of basin in Hydrologic Region 35

Percent of basin in Hydrologic Region 36

Percent of basin in Hydrologic Region 37

Percent of basin in Hydrologic Region 38

Percent of basin in Hydrologic Region 39

Percent of basin in Hydrologic Region 40

Percent of basin in Hydrologic Region 41

Percent of basin in Hydrologic Region 42

Percent of basin in Hydrologic Region 43

Percent of basin in Hydrologic Region 44

Percent of basin in Hydrologic Region 45

Percent of basin in Hydrologic Region 46

Percent of basin in Hydrologic Region 47

Percent of basin in Hydrologic Region 48

Percent of basin in Hydrologic Region 49

Percent of basin in Hydrologic Region 50

Percent of basin in Hydrologic Region 51

Percent of basin in Hydrologic Region 52

Percent of basin in Hydrologic Region 53

Percent of basin in Hydrologic Region 54

Percent of basin in Hydrologic Region 55

Percent of basin in Hydrologic Region 56

Percent of basin in Hydrologic Region 57

Percent of basin in Hydrologic Region 58

Percent of basin in Hydrologic Region 59

Percent of basin in Hydrologic Region 60

Percent of basin in Hydrologic Region 61

Percent of basin in Hydrologic Region 62

Percent of basin in Hydrologic Region 63

Percent of basin in Hydrologic Region 64

Percent of basin in Hydrologic Region 65

Percent of basin in Hydrologic Region 66

Percent of basin in Hydrologic Region 67

Percent of basin in Hydrologic Region 68

Percent of basin in Hydrologic Region 69

Percent of basin in Hydrologic Region 70

Percent of basin in Hydrologic Region 71

Percent of basin in Hydrologic Region 72

Percent of basin in Hydrologic Region 73

Percent of basin in Hydrologic Region 74

Percent of basin in Hydrologic Region 75

Percent of basin in Hydrologic Region 76

Percent of basin in Hydrologic Region 77

Percent of basin in Hydrologic Region 78

Percent of basin in Hydrologic Region 79

Percent of basin in Hydrologic Region 80

Percent of basin in Hydrologic Region 81

Percent of basin in Hydrologic Region 82

Percent of basin in Hydrologic Region 83

Percent of basin in Hydrologic Region 84

Percent of basin in Hydrologic Region 85

Percent of basin in Hydrologic Region 86

Percent of basin in Hydrologic Region 87

Percent of basin in Hydrologic Region 88

Percent of basin in Hydrologic Region 89

Percent of basin in Hydrologic Region 90

Percent of basin in Hydrologic Region 91

Percent of basin in Hydrologic Region 92

Percent of basin in Hydrologic Region 93

Percent of basin in Hydrologic Region 94

Percent of basin in Hydrologic Region 95

Percent of basin in Hydrologic Region 96

Percent of basin in Hydrologic Region 97

Percent of basin in Hydrologic Region 98

Percent of basin in Hydrologic Region 99

Percent of basin in Hydrologic Region 100

U-2707 FARM PART
12/1/11

U-2101
12/1/81

09

2. PRODUCT DETAILS AND FABRICATION

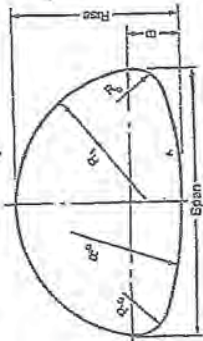

Table 2.10 Sizes and Layout Details—OSP Pipe Arch.
2 1/2% x 1/2 in. Corrugation

Spoke Diameter, in.	Span, ft.	Rise, in.	Waterway Area, (sq ft)	Layout Dimensions				
				W	H	R ₁	R ₂	R ₃
16	17	13	1.1	4 1/2	3 1/2	10 1/4	8 3/4	25 1/4
20	21	15	1.5	4 3/4	4 1/4	10 3/4	10 1/4	23 1/4
24	24	18	2.2	5 1/4	4 3/4	11 1/4	11 1/4	21 1/4
28	28	20	3.0	6 1/4	5 1/4	12 1/4	12 1/4	19 1/4
32	32	22	4.0	7 1/4	6 1/4	13 1/4	13 1/4	17 1/4
36	36	24	5.2	8 1/4	7 1/4	14 1/4	14 1/4	15 1/4
40	40	26	6.6	9 1/4	8 1/4	15 1/4	15 1/4	13 1/4
44	44	28	8.2	10 1/4	9 1/4	16 1/4	16 1/4	11 1/4
48	48	30	10.0	11 1/4	10 1/4	17 1/4	17 1/4	9 1/4
52	52	32	12.0	12 1/4	11 1/4	18 1/4	18 1/4	7 1/4
56	56	34	14.2	13 1/4	12 1/4	19 1/4	19 1/4	5 1/4
60	60	36	16.6	14 1/4	13 1/4	20 1/4	20 1/4	3 1/4
64	64	38	19.2	15 1/4	14 1/4	21 1/4	21 1/4	1 1/4
68	68	40	22.0	16 1/4	15 1/4	22 1/4	22 1/4	0
72	72	42	25.0	17 1/4	16 1/4	23 1/4	23 1/4	0

Table 2.10 Sizes and Layout Details—OSP Pipe Arch
3 X 1 or 2 X 1 in. Corrugation

Spoke Diameter, in.	Span, ft.	Rise, in.	Waterway Area, (sq ft)	Layout Dimensions				
				W	H	R ₁	R ₂	R ₃
40	53 1/4	38	11.7	15 1/4	10 1/4	20 1/4	20 1/4	7 1/4
44	57 1/4	40	15.0	16 1/4	10 1/4	21 1/4	21 1/4	5 1/4
48	61 1/4	42	18.2	17 1/4	10 1/4	22 1/4	22 1/4	3 1/4
52	65 1/4	44	21.4	18 1/4	10 1/4	23 1/4	23 1/4	1 1/4
56	69 1/4	46	24.6	19 1/4	10 1/4	24 1/4	24 1/4	0
60	73 1/4	48	27.8	20 1/4	10 1/4	25 1/4	25 1/4	0
64	77 1/4	50	31.0	21 1/4	10 1/4	26 1/4	26 1/4	0
68	81 1/4	52	34.2	22 1/4	10 1/4	27 1/4	27 1/4	0
72	85 1/4	54	37.4	23 1/4	10 1/4	28 1/4	28 1/4	0
76	89 1/4	56	40.6	24 1/4	10 1/4	29 1/4	29 1/4	0
80	93 1/4	58	43.8	25 1/4	10 1/4	30 1/4	30 1/4	0
84	97 1/4	60	47.0	26 1/4	10 1/4	31 1/4	31 1/4	0
88	101 1/4	62	50.2	27 1/4	10 1/4	32 1/4	32 1/4	0
92	105 1/4	64	53.4	28 1/4	10 1/4	33 1/4	33 1/4	0
96	109 1/4	66	56.6	29 1/4	10 1/4	34 1/4	34 1/4	0
100	113 1/4	68	59.8	30 1/4	10 1/4	35 1/4	35 1/4	0
104	117 1/4	70	63.0	31 1/4	10 1/4	36 1/4	36 1/4	0
108	121 1/4	72	66.2	32 1/4	10 1/4	37 1/4	37 1/4	0
112	125 1/4	74	69.4	33 1/4	10 1/4	38 1/4	38 1/4	0
116	129 1/4	76	72.6	34 1/4	10 1/4	39 1/4	39 1/4	0
120	133 1/4	78	75.8	35 1/4	10 1/4	40 1/4	40 1/4	0
124	137 1/4	80	79.0	36 1/4	10 1/4	41 1/4	41 1/4	0
128	141 1/4	82	82.2	37 1/4	10 1/4	42 1/4	42 1/4	0
132	145 1/4	84	85.4	38 1/4	10 1/4	43 1/4	43 1/4	0
136	149 1/4	86	88.6	39 1/4	10 1/4	44 1/4	44 1/4	0
140	153 1/4	88	91.8	40 1/4	10 1/4	45 1/4	45 1/4	0
144	157 1/4	90	95.0	41 1/4	10 1/4	46 1/4	46 1/4	0
148	161 1/4	92	98.2	42 1/4	10 1/4	47 1/4	47 1/4	0
152	165 1/4	94	101.4	43 1/4	10 1/4	48 1/4	48 1/4	0
156	169 1/4	96	104.6	44 1/4	10 1/4	49 1/4	49 1/4	0
160	173 1/4	98	107.8	45 1/4	10 1/4	50 1/4	50 1/4	0
164	177 1/4	100	111.0	46 1/4	10 1/4	51 1/4	51 1/4	0
168	181 1/4	102	114.2	47 1/4	10 1/4	52 1/4	52 1/4	0
172	185 1/4	104	117.4	48 1/4	10 1/4	53 1/4	53 1/4	0
176	189 1/4	106	120.6	49 1/4	10 1/4	54 1/4	54 1/4	0
180	193 1/4	108	123.8	50 1/4	10 1/4	55 1/4	55 1/4	0
184	197 1/4	110	127.0	51 1/4	10 1/4	56 1/4	56 1/4	0
188	201 1/4	112	130.2	52 1/4	10 1/4	57 1/4	57 1/4	0
192	205 1/4	114	133.4	53 1/4	10 1/4	58 1/4	58 1/4	0
196	209 1/4	116	136.6	54 1/4	10 1/4	59 1/4	59 1/4	0
200	213 1/4	118	139.8	55 1/4	10 1/4	60 1/4	60 1/4	0
204	217 1/4	120	143.0	56 1/4	10 1/4	61 1/4	61 1/4	0
208	221 1/4	122	146.2	57 1/4	10 1/4	62 1/4	62 1/4	0
212	225 1/4	124	149.4	58 1/4	10 1/4	63 1/4	63 1/4	0
216	229 1/4	126	152.6	59 1/4	10 1/4	64 1/4	64 1/4	0
220	233 1/4	128	155.8	60 1/4	10 1/4	65 1/4	65 1/4	0
224	237 1/4	130	159.0	61 1/4	10 1/4	66 1/4	66 1/4	0
228	241 1/4	132	162.2	62 1/4	10 1/4	67 1/4	67 1/4	0
232	245 1/4	134	165.4	63 1/4	10 1/4	68 1/4	68 1/4	0
236	249 1/4	136	168.6	64 1/4	10 1/4	69 1/4	69 1/4	0
240	253 1/4	138	171.8	65 1/4	10 1/4	70 1/4	70 1/4	0

Dimension shown not for specification purposes, subject to manufacturing tolerances.

REVISIONS
PAGE 20 OF 21
DRAWING NO. 1711/A

U-2707 PAVEN PATH
12/1/11

CHART 34B

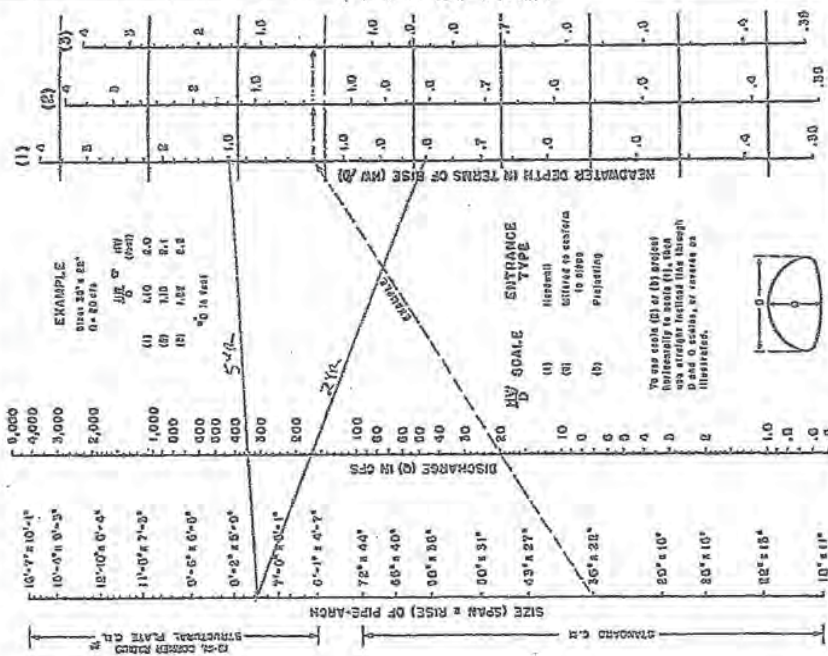

ADDITIONAL SIZES NOT DIMENSIONED ARE LISTED IN FABRICATIONS CATALOG BUREAU OF PUBLIC ROADS WASH. D.C.

DIVISION OF HIGHWAYS
 MISSOURI
 INCOMPLETE PLANS
 TO BE USED FOR ACCURATE
 PRELIMINARY PLANS
 DO NOT USE FOR CONSTRUCTION

RI
Sta. 9 + 20.00 to 18 + 00.00

TYPICAL SECTION RIFFLE
 BANKFULL AREA 15.0 SQ. FT



TYPICAL SECTION POOL LEFT
 BANKFULL AREA 19.2 SQ. FT



TYPICAL SECTION POOL RIGHT
 BANKFULL AREA 19.2 SQ. FT



RI
Sta. 0 + 00.00 to 9 + 20.00

TYPICAL SECTION RIFFLE
 BANKFULL AREA 10.0 SQ. FT



TYPICAL SECTION POOL LEFT
 BANKFULL AREA 11.9 SQ. FT



TYPICAL SECTION POOL RIGHT
 BANKFULL AREA 11.9 SQ. FT

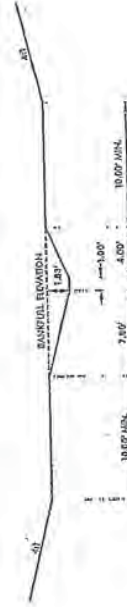

9/20/17

REVISIONS

2/4/2017 10:52 AM C:\Users\jshelton\OneDrive\Documents\112727.mxd gshelton

INCOMPLETE PLANS
 TO BE FOR THE USE OF A
 PRELIMINARY PLANS
 TO BE FOR THE USE OF A
 CONTRACTOR

EXAMPLE OF PUMP-AROUND OPERATION

- NOTES:**
- 1) All excavation shall be performed in only dry or isolated sections of channel.
 - 2) ImperVIOUS dikes are to be used to isolate work from stream flow when necessary.
 - 3) All graded areas shall be stabilized within 24 hours.
 - 4) Maintenance of stream flow operations shall be incidental to the work. This includes polyethylene sheeting, diversion pipes, pumps and hoses.
 - 5) Pumps and hoses shall be of sufficient size to dewater the work area.

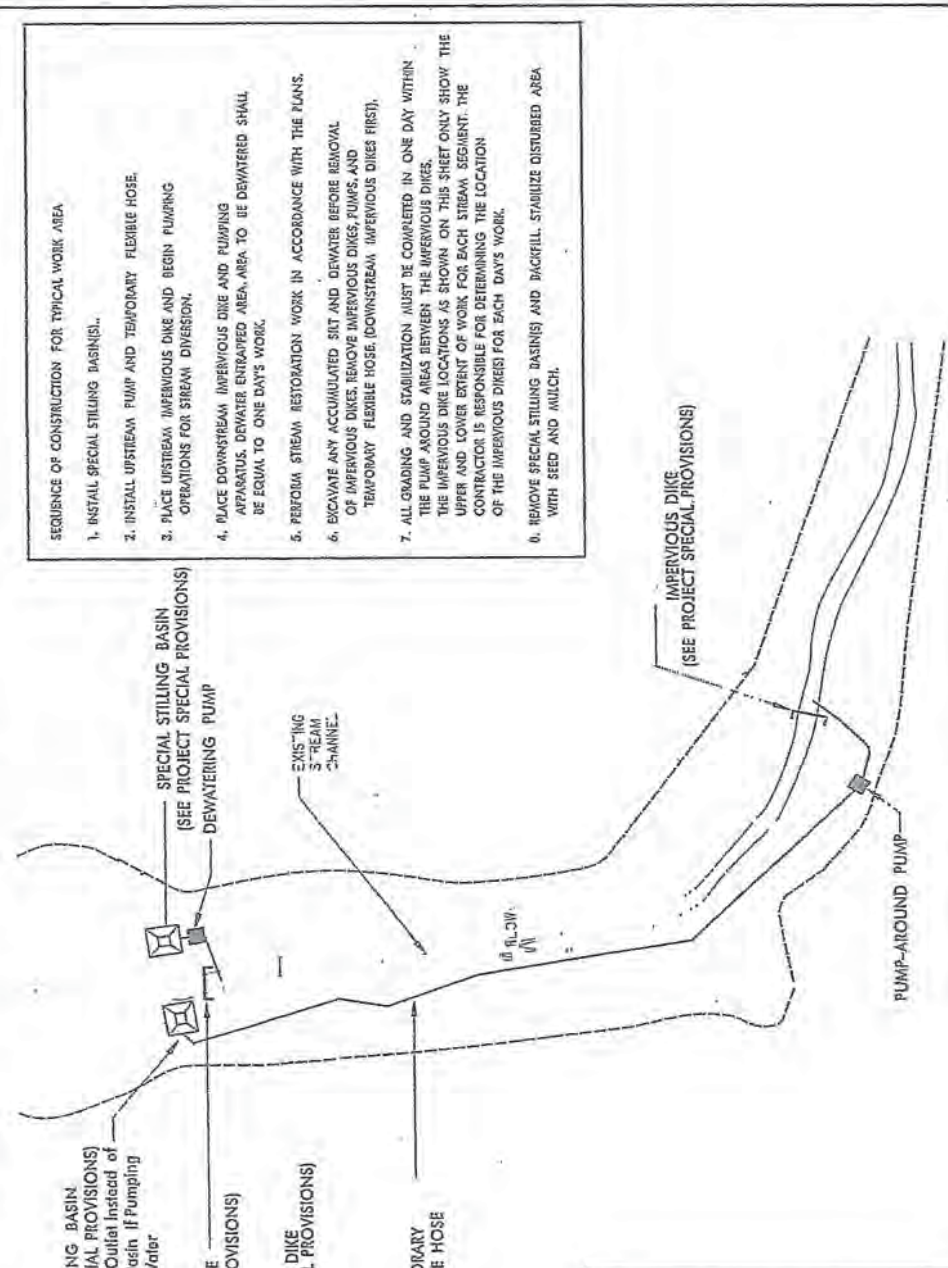

- SEQUENCE OF CONSTRUCTION FOR TYPICAL WORK AREA**
1. INSTALL SPECIAL STILLING BASIN(S).
 2. INSTALL UPSTREAM PUMP AND TEMPORARY FLEXIBLE HOSE.
 3. PLACE UPSTREAM IMPERVIOUS DIKE AND BEGIN PUMPING OPERATIONS FOR STREAM DIVERSION.
 4. PLACE DOWNSTREAM IMPERVIOUS DIKE AND PUMPING APPARATUS. DEWATER ENTRAPPED AREA TO BE DEWATERED SHALL BE EQUAL TO ONE DAY'S WORK.
 5. RESTORE STREAM RESTORATION WORK IN ACCORDANCE WITH THE PLANS.
 6. DCAVATE ANY ACCUMULATED SILT AND DEWATER BEFORE REMOVAL OF IMPERVIOUS DIKES. REMOVE IMPERVIOUS DIKES, PUMPS, AND TEMPORARY FLEXIBLE HOSE (DOWNSTREAM IMPERVIOUS DIKES FIRST).
 7. ALL GRADING AND STABILIZATION MUST BE COMPLETED IN ONE DAY WITHIN THE PUMP AROUND AREAS BETWEEN THE IMPERVIOUS DIKES. THE IMPERVIOUS DIKE LOCATIONS AS SHOWN ON THIS SHEET ONLY SHOW THE UPPER AND LOWER EXTENT OF WORK FOR EACH STREAM SEGMENT. THE CONTRACTOR IS RESPONSIBLE FOR DETERMINING THE LOCATION OF THE IMPERVIOUS DIKES FOR EACH DAY'S WORK.
 8. REMOVE SPECIAL STILLING BASIN(S) AND BACKFILL, STABILIZE DISTURBED AREA WITH SEED AND MULCH.

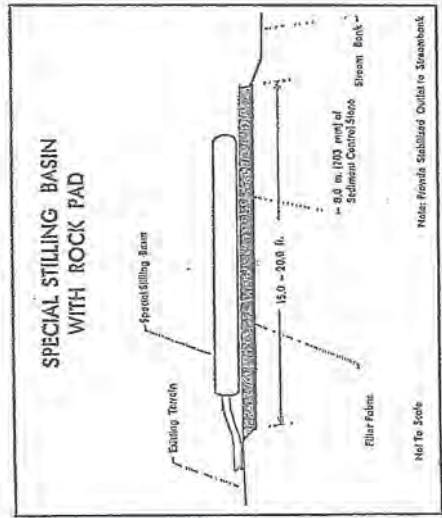

DESIGNED BY
ENGINEER

INCOMPLETE PLANS
FOR PRELIMINARY CONSTRUCTION

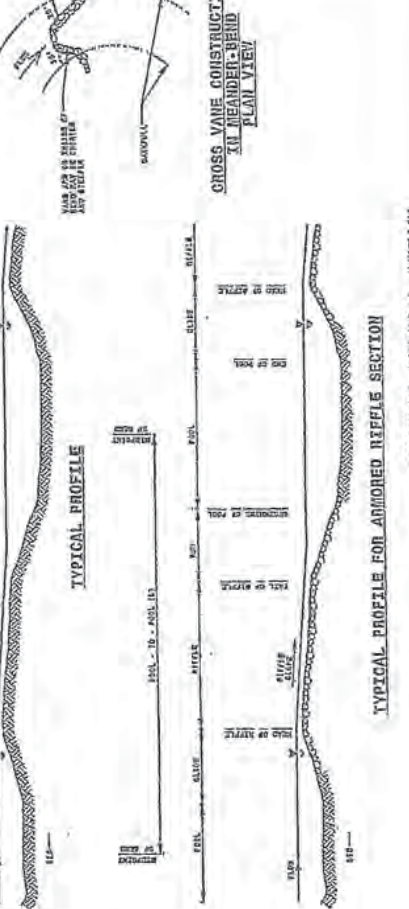
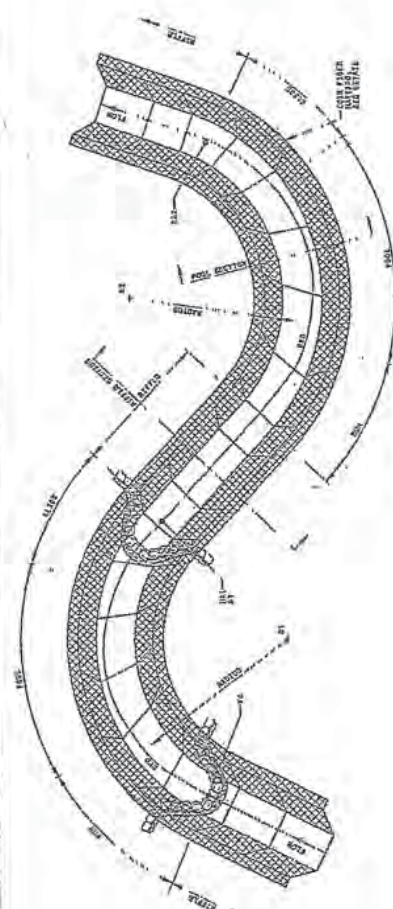
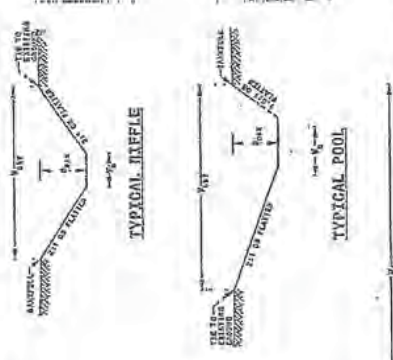

CROSS-SECTION DIMENSIONS

SECTION	RIFLE	CHANNEL	BANKFULL POOL	CHANNEL	RIFLE	CHANNEL	BANKFULL POOL	CHANNEL
AREA 1	10.0	10.0	10.0	10.0	10.0	10.0	10.0	10.0
AREA 2	10.0	10.0	10.0	10.0	10.0	10.0	10.0	10.0
AREA 3	10.0	10.0	10.0	10.0	10.0	10.0	10.0	10.0
AREA 4	10.0	10.0	10.0	10.0	10.0	10.0	10.0	10.0
AREA 5	10.0	10.0	10.0	10.0	10.0	10.0	10.0	10.0
AREA 6	10.0	10.0	10.0	10.0	10.0	10.0	10.0	10.0
AREA 7	10.0	10.0	10.0	10.0	10.0	10.0	10.0	10.0
AREA 8	10.0	10.0	10.0	10.0	10.0	10.0	10.0	10.0
AREA 9	10.0	10.0	10.0	10.0	10.0	10.0	10.0	10.0
AREA 10	10.0	10.0	10.0	10.0	10.0	10.0	10.0	10.0

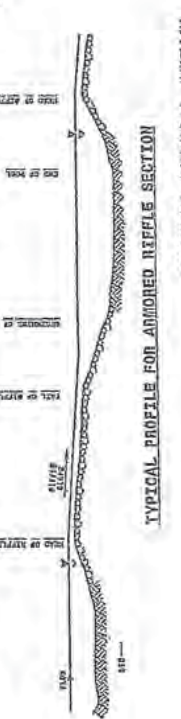

REVISIONS

PROVIDES
 PROVISIONS
 FOR
 ANCHORS
 TO
 BE
 USED
 IN
 THE
 CONSTRUCTION
 OF
 COIR
 FIBER
 MATTING

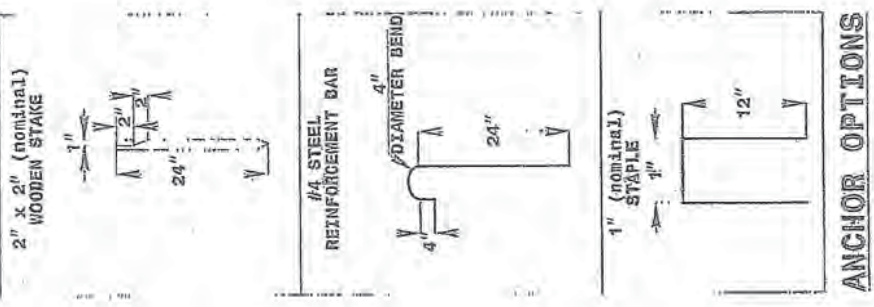

ANCHOR OPTIONS

- NOTES:**
1. IN AREAS TO BE MATTED, ALL SEEDING, SOIL AMENDMENTS, AND SOIL PREPARATION MUST BE COMPLETED IN ACCORDANCE WITH THE PROJECT SPECIFICATIONS PRIOR TO PLACEMENT OF COIR FIBER MATTING.
 2. WOODEN STAKES MAY BE USED IN PLACE OF REBAR OR STAPLES AS DIRECTED BY THE ENGINEER.

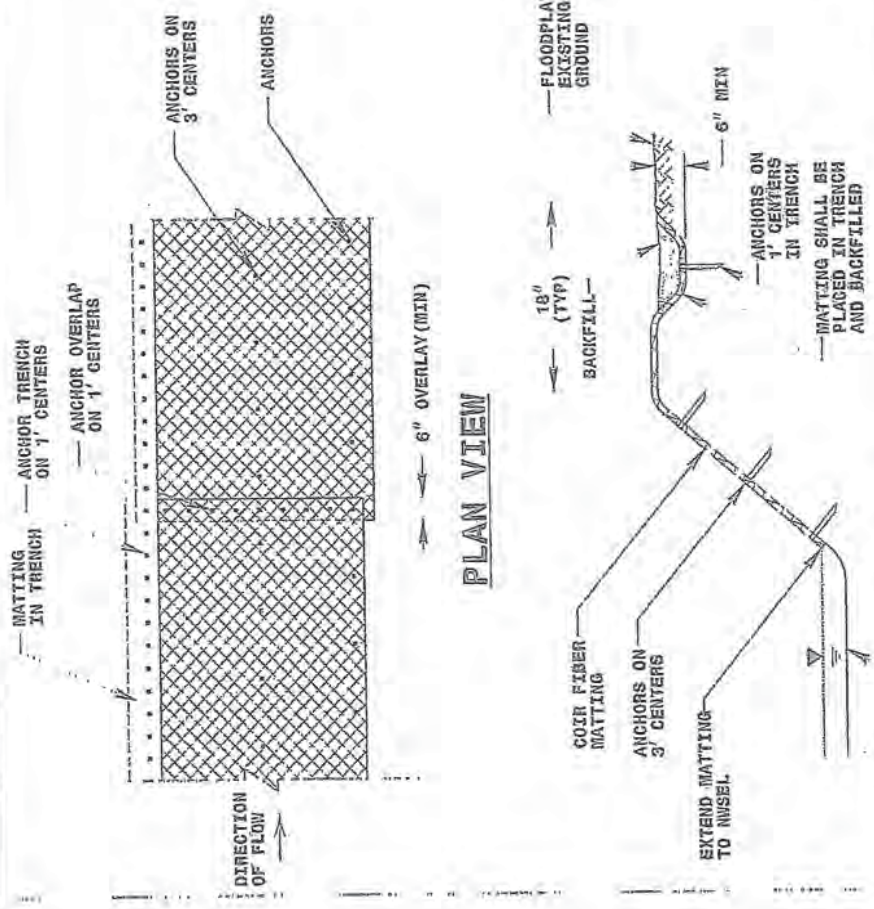

PLAN VIEW

TYPICAL CROSS SECTION

COIR FIBER MATTING DETAIL

NOT TO SCALE

5/28/

REVISIONS

12/1/2017 10:51:11 AM C:\Users\j\Documents\170501\170501.dwg

HYDRAULIC ENGINEERING
 INCOMPLETE PLANS
 NO USE FOR AS-BUILT RECORDS
 PRELIMINARY PLANS
 TO BE FOR THE CONTRACTOR'S USE

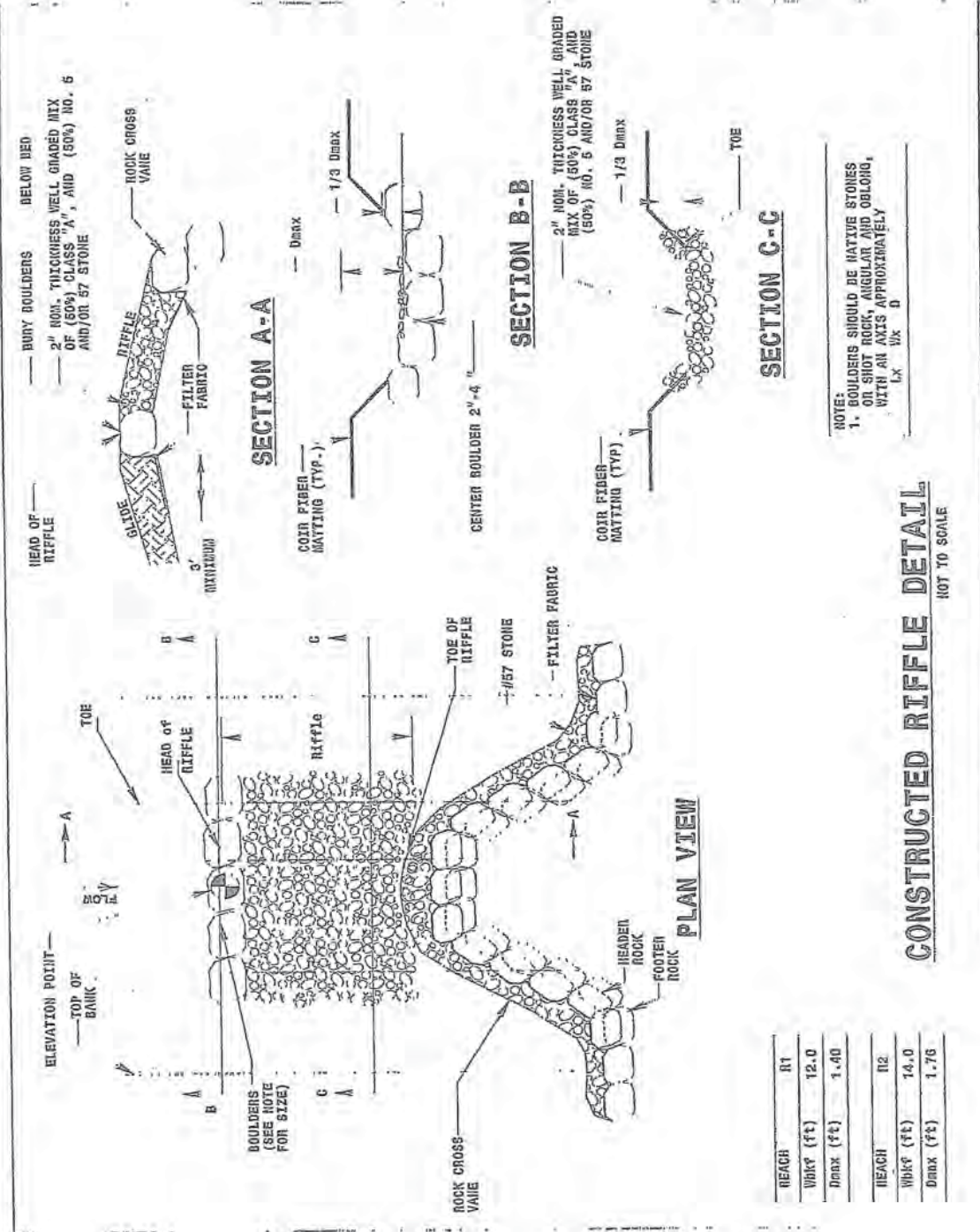

NOTES:
 1. BOULDERS SHOULD BE NATIVE STONES, OR SHOT ROCK, ANGULAR AND OBLONG, WITH AN AXIS APPROXIMATELY
 Lx Wx D

CONSTRUCTED RIFFLE DETAIL
 NOT TO SCALE

REACH	R1
Width (ft)	12.0
Depth (ft)	1.40
REACH	R2
Width (ft)	14.0
Depth (ft)	1.75

5/23

REVISIONS

7/2/2018 10:00 AM

DESIGNED BY
ENGINEER

PROCESSED BY
ARCHITECT

INCOMPLETE PLANS
DO NOT USE FOR CONSTRUCTION
PRELIMINARY PLANS
DO NOT USE FOR CONSTRUCTION

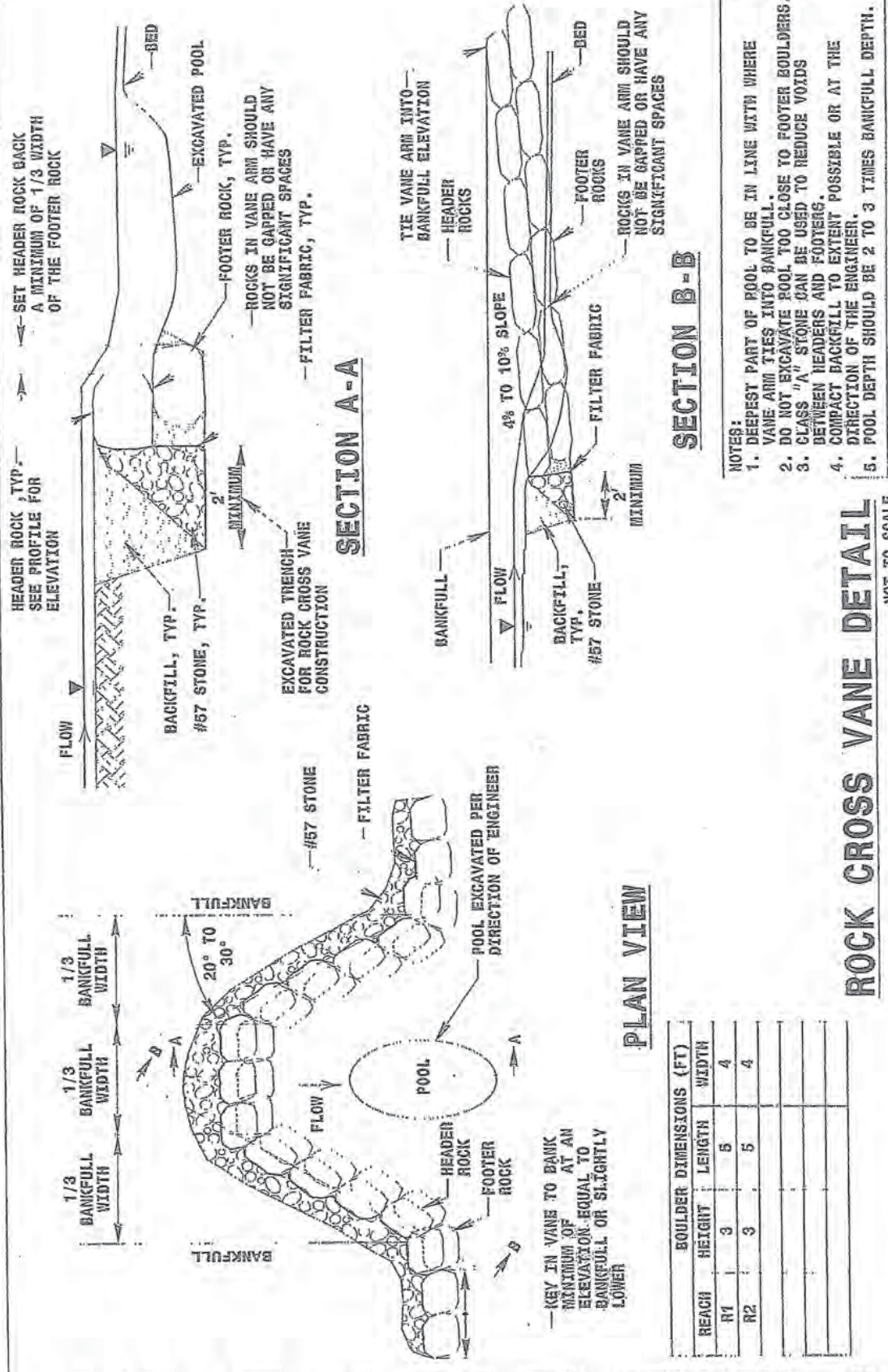

ROCK CROSS VANE DETAIL

NOT TO SCALE

BOULDER DIMENSIONS (FT)			
REACH	HEIGHT	LENGTH	WIDTH
R1	3	5	4
R2	3	5	4

REVISIONS

DATE

BY

DESCRIPTION

INCOMPLETE PLANS
DO NOT USE FOR CONSTRUCTION

PRELIMINARY PLANS
DO NOT USE FOR CONSTRUCTION

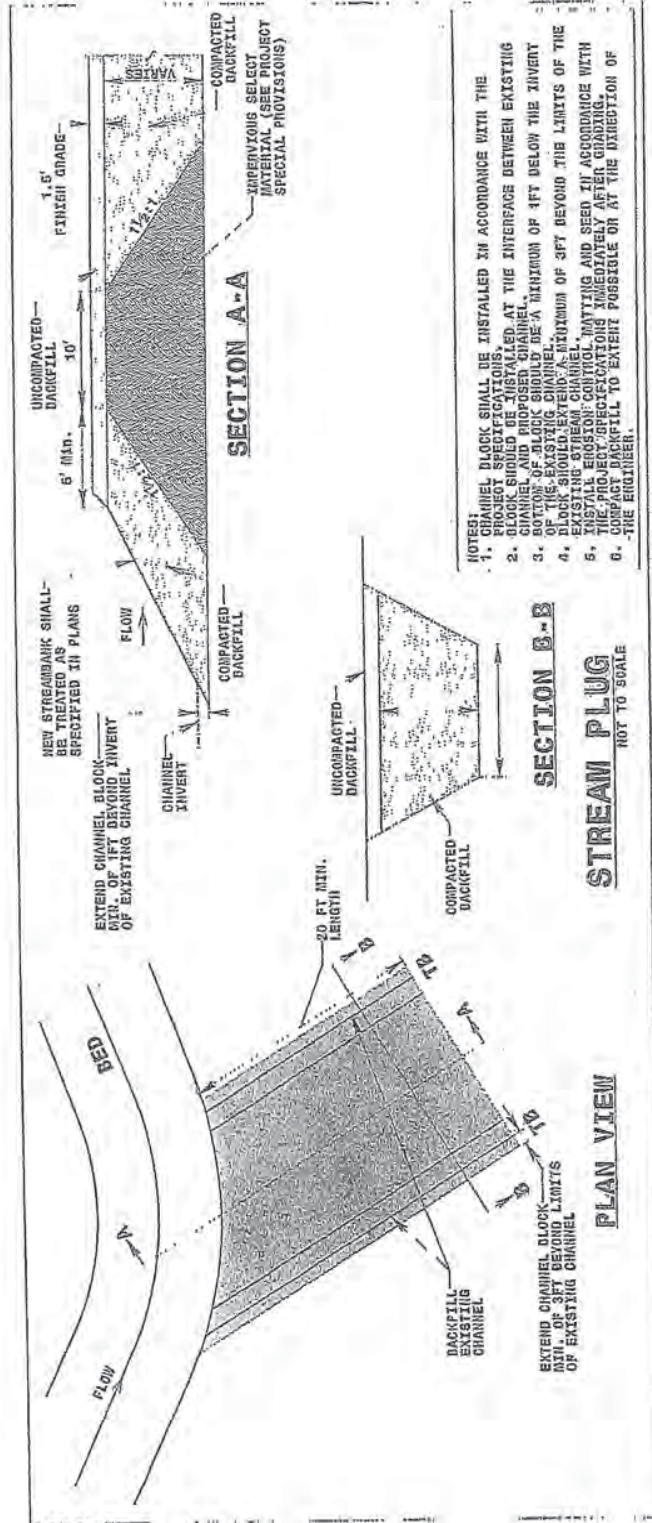

11/27/2011 10:00 AM

REV. SHEET NO. HYDRAULIC ENGINEER
 INCOMPLETE PLANS
 PRELIMINARY PLANS
 DO NOT USE FOR CONSTRUCTION

**PIPE WITH BAFFLES
 FARM PATH CROSSING
 U-2707 CLEMMONS, NC**

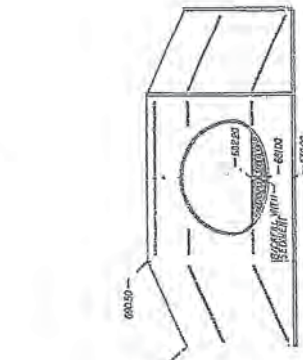

OUTLET WITH HEADWALL

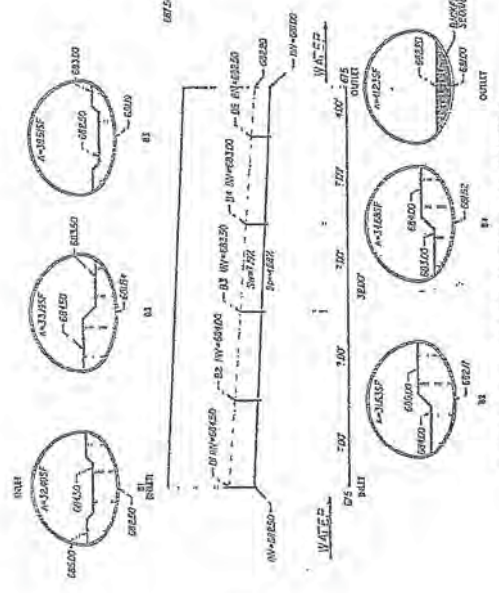

PROFILE WITH CROSS SECTIONS AT BAFFLES

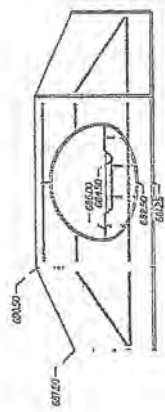

INLET WITH HEADWALL

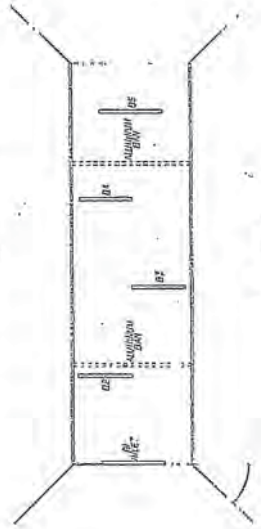

PLAN VIEW

REVISIONS

12/4/2018 10:58 AM C:\Users\jshelton\OneDrive\Documents\12/2/17 mit design

NW 31811 PLG. HYDRAULICS ENGINEER	INCOMPLETE PLANS AS SET OUT BY PRELIMINARY PLANS IN 1957 AND 1958
---	--

LIVE STAKE DETAIL

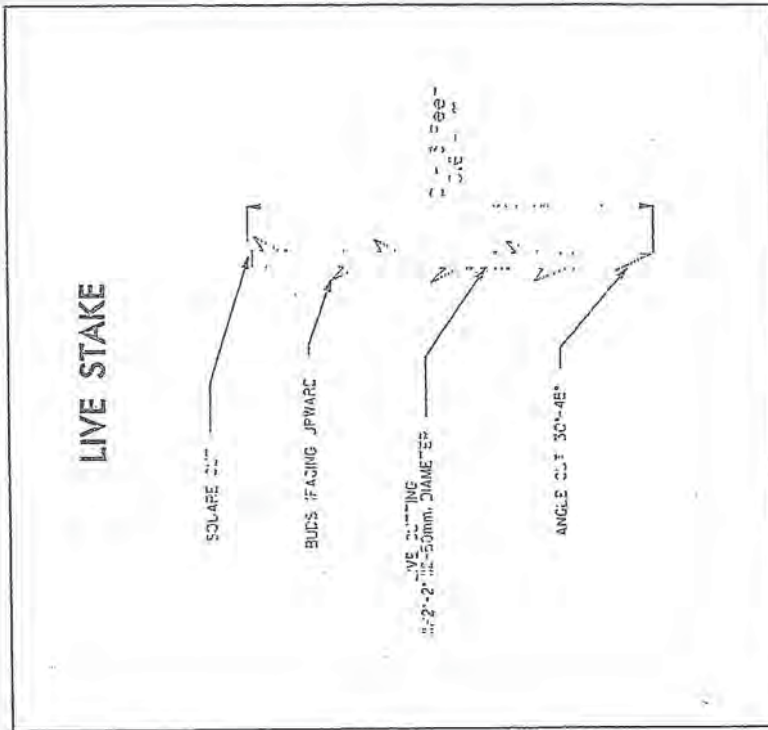
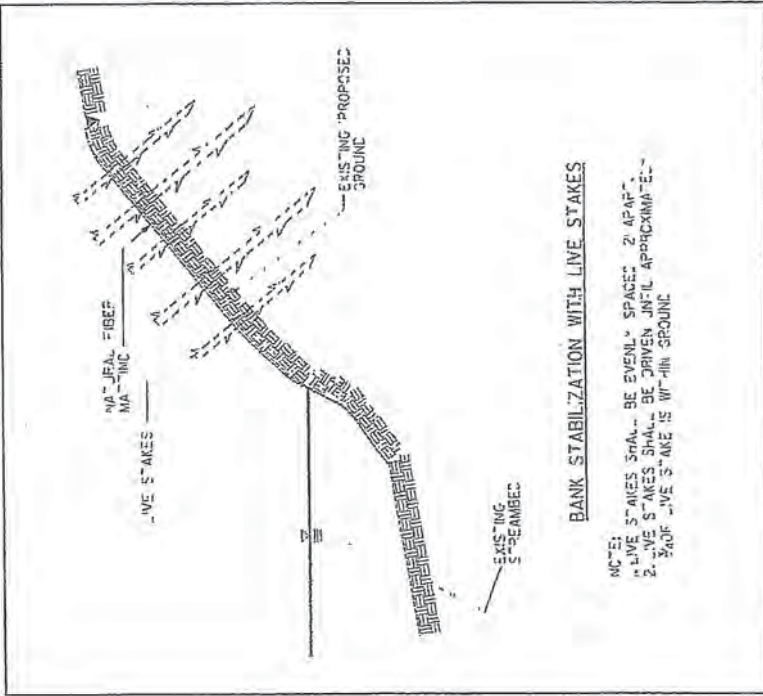

REVISIONS

8/9/2018 11:27 AM

INCOMPLETE PLANS
DO NOT USE FOR CONSTRUCTION
PUBLISHED BY PLANS
BY THE STATE OF FLORIDA

- TYPE 1 STREAMBANK REFORESTATION SHALL BE PLANTED 3 FT. TO 5 FT. ON CENTER, RANDOM SPACING, AVERAGING 4 FT. ON CENTER, APPROXIMATELY 2724 PLANTS PER ACRE.
- TYPE 2 STREAMBANK REFORESTATION SHALL BE PLANTED 6 FT. TO 10 FT. ON CENTER, RANDOM SPACING, AVERAGING 8 FT. ON CENTER, APPROXIMATELY 660 PLANTS PER ACRE.
- NOTE: TYPE 1 AND TYPE 2 STREAMBANK REFORESTATION SHALL BE PAID FOR AS "STREAMBANK REFORESTATION"

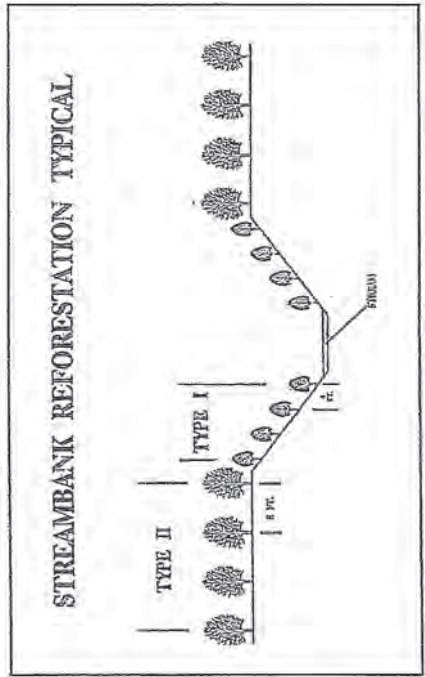

STREAMBANK REFORESTATION

MIXTURE, TYPE, SIZE AND FINISH SHALL CONFORM TO THE FOLLOWING

TYPE 1	TYPE 2
50% SALIX NIGRA	25% PRAXINUS PENNSYLVANICA
50% CORNUS AMOMUM	25% QUERCUS PHELLOS
	25% QUERCUS MICHAEXII
	25% BETULA NIGRA
BLACK WILLOW 2 ft - 3 ft LIVE STAKES	GREEN ASH 12 in - 18 in BR
SLAY DOGWOOD 2 ft - 3 ft LIVE STAKES	WILLOW OAK 12 in - 18 in BR
	SWAMP CHESTNUT OAK 12 in - 18 in BR
	RIVER BIRCH 12 in - 18 in BR

- SEE PLAN SHEETS FOR AREAS TO BE PLANTED

STREAMBANK REFORESTATION
DETAIL SHEET
N.C. HOT - ROADSIDE ENVIRONMENTAL UNIT

PLANTING DETAILS

LIVE STAKES PLANTING DETAIL

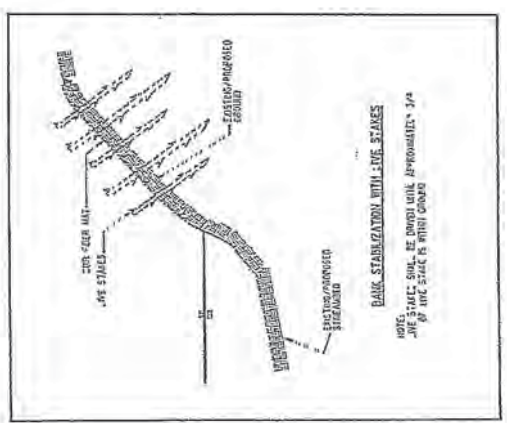
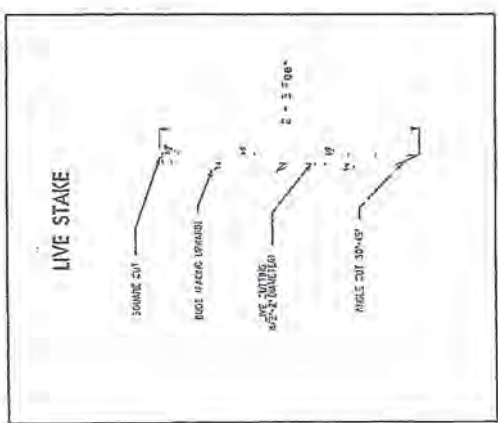

BAREROOT PLANTING DETAIL
DIBBLE PLANTING METHOD
USING THE IBC PLANTING BAR

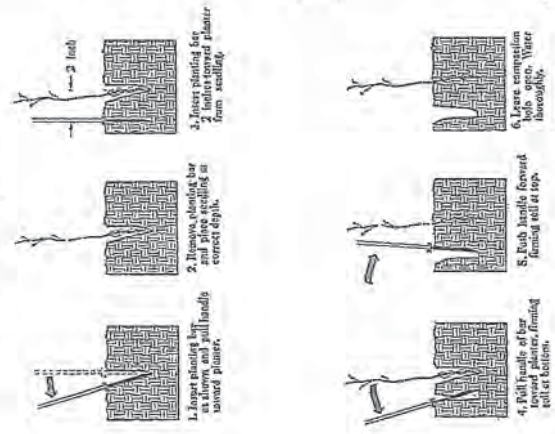

PLANTING NOTES:

- PLANTING BAG: Using plastic seedling bags, ensure that the seedling is placed in the bag and the root system is not damaged.
- IBC PLANTING BAR: Planting bar shall have a 1/2 inch diameter hole for the seedling and shall be 12 inches long and 1 inch wide at center.
- HOT PRUNING: All seedlings shall be root pruned, if necessary, so that the root system is 10 inches below the root collar.

FORWARD WORK
ISSUED

INCOMPLETE PLANS
DO NOT USE FOR CONSTRUCTION

PRELIMINARY PLANS
DO NOT USE FOR CONSTRUCTION

ALIGNMENT DATA
REACH 1

Station	Curve/Tangent Number	Curve/Tangent Length (ft)	Delta Angle	Radius (ft)	Chord Length (ft)	Chord Bearing	Chord Length (ft)	Bearing (ft)
14+01.26	PT R1-25 to PC R1-27	8.81						
	Curve R1-27	47.45	77° 41' 04.23" (RT)	49.00	49.00	N 4° 02' 16.07" E		35.00
14+52.79	PT R1-27 to PC R1-28	9.08						
	Curve R1-28	37.68	70° 26' 23.09" (LT)	35.00	35.00	N 82° 59' 48.18" E		35.00
15+04.11	PT R1-28 to PC R1-29	8.64						
	Curve R1-29	50.64	78° 25' 08.69" (RT)	46.78	46.78	N 4° 43' 59' 48.18" E		35.00
15+60.05	PT R1-29 to PC R1-30	6.20						
	Curve R1-30	46.07	78° 38' 56.63" (LT)	43.09	43.09	N 82° 59' 48.18" E		35.00
16+13.40	PT R1-30 to PC R1-31	7.87						
	Curve R1-31	50.82	76° 48' 38.09" (RT)	47.38	47.38	N 4° 43' 59' 48.18" E		35.00
16+74.47	PT R1-31 to PC R1-32	8.06						
	Curve R1-32	51.82	82° 38' 26.50" (LT)	47.54	47.54	N 82° 58' 46.49" E		36.00
17+38.10	PT R1-32 to PC R1-33	11.29						
	Curve R1-33	30.43	94° 02' 36.09" (RT)	27.00	27.00	N 4° 43' 59' 48.18" E		40.00
18+34.91	PC R1-33 to Point 45001	16.30						
	Point 45001							

Station	Curve/Tangent Number	Curve/Tangent Length (ft)	Delta Angle	Radius (ft)	Chord Length (ft)	Chord Bearing	Chord Length (ft)	Bearing (ft)
0+00.00	Point 45000							
	Point 45000 to PC R1-1	10.88						
0+10.48	Curve R1-1	21.11	24° 41' 20.78" (RT)	49.00	20.95	N 41° 11' 44.10" E		30.00
0+35.40	PT R1-1 to PC R1-2	2.86						
	Curve R1-2	46.84	70° 05' 38.42" (LT)	35.00	40.20	N 80° 03' 24.00" E		49.00
0+83.86	PT R1-2 to PC R1-3	4.84						
	Curve R1-3	47.16	90° 16' 06.55" (RT)	31.00	48.94	N 82° 59' 48.18" E		35.00
1+27.42	PT R1-3 to PC R1-4	7.60						
	Curve R1-4	44.33	89° 03' 29.37" (LT)	35.00	40.09	N 62° 01' 43.59" E		35.00
2+04.32	PT R1-4 to PC R1-5	4.53						
	Curve R1-5	46.76	84° 28' 38.45" (RT)	30.00	40.33	N 59° 40' 12.69" E		30.00
2+55.79	PT R1-5 to PC R1-6	6.76						
	Curve R1-6	47.16	83° 43' 13.66" (LT)	32.00	42.71	N 60° 05' 55.99" E		32.00
3+07.57	PT R1-6 to PC R1-7	47.16						
	Curve R1-7	43.67	77° 11' 40.66" (RT)	35.00	43.67	N 83° 15' 19.66" E		35.00
3+66.14	PT R1-7 to PC R1-8	19.43						
	Curve R1-8	7.44	81° 10' 27.46" (LT)	37.00	40.14	N 63° 51' 09.29" E		37.00
4+32.01	PT R1-8 to PC R1-9	20.33						
	Curve R1-9	5.73	99° 26' 23.64" (RT)	29.00	44.03	N 84° 51' 46.39" E		29.00
4+78.05	PT R1-9 to PC R1-10	49.84						
	Curve R1-10	4.89	101° 59' 45.99" (LT)	28.00	43.52	N 65° 19' 03.70" E		28.00
5+35.78	PT R1-10 to PC R1-11	57.24						
	Curve R1-11	4.18	99° 29' 13.42" (RT)	39.00	48.82	N 11° 49' 11.01" E		39.00
5+91.70	PT R1-11 to PC R1-12	39.06						
	Curve R1-12	4.44	75° 21' 18.07" (LT)	30.00	36.67	N 89° 12' 24.83" E		30.00
6+35.89	PT R1-12 to PC R1-13	43.55						
	Curve R1-13	6.15	93° 42' 35.01" (RT)	29.00	42.38	N 51° 31' 45.40" E		29.00
6+89.48	PT R1-13 to PC R1-14	59.58						
	Curve R1-14	6.33	94° 17' 47.57" (LT)	36.00	52.78	N 60° 47' 33.87" E		36.00
7+46.72	PT R1-14 to PC R1-15	34.19						
	Curve R1-15	5.62	69° 38' 00.70" (RT)	28.00	32.11	N 48° 25' 14.01" E		28.00
7+90.12	PT R1-15 to PC R1-16	45.15						
	Curve R1-16	10.20	83° 57' 02.38" (LT)	31.00	41.26	N 41° 40' 42.92" E		31.00
8+30.12	PT R1-16 to PC R1-17	49.20						
	Curve R1-17	5.03	80° 42' 38.65" (RT)	35.00	45.33	N 80° 26' 14.21" E		35.00
8+81.46	PT R1-17 to PC R1-18	51.20						
	Curve R1-18	5.85	98° 46' 19.23" (LT)	30.00	45.54	N 40° 18' 30.95" E		30.00
9+42.01	PT R1-18 to PC R1-19	49.02						
	Curve R1-19	4.89	96° 51' 00.37" (RT)	29.00	43.39	N 31° 17' 40.65" E		29.00
10+53.22	PT R1-19 to PC R1-20	53.31						
	Curve R1-20	7.48	90° 22' 21.52" (LT)	38.00	49.04	N 78° 46' 21.82" E		38.00
10+76.93	PT R1-20 to PC R1-21	39.93						
	Curve R1-21	6.74	81° 22' 47.26" (RT)	29.00	36.63	N 1° 55' 49.70" W		29.00
11+23.38	PT R1-21 to PC R1-22	52.17						
	Curve R1-22	4.45	102° 56' 59.09" (LT)	29.00	45.39	N 80° 06' 51.58" E		29.00
11+80.16	PT R1-22 to PC R1-23	36.66						
	Curve R1-23	5.17	107° 26' 21.65" (RT)	32.00	49.54	N 27° 51' 09.41" E		32.00
12+41.98	PT R1-23 to PC R1-24	43.64						
	Curve R1-24	5.39	85° 20' 51.13" (LT)	30.00	39.89	N 78° 24' 26.23" E		30.00
12+80.22	PT R1-24 to PC R1-25	51.80						
	Curve R1-25	10.49	82° 27' 00.41" (RT)	36.00	47.45	N 4° 40' 36.90" W		36.00
13+33.21	PT R1-25 to PC R1-26	39.24						
	Curve R1-26		72° 31' 07.44" (LT)	31.00	36.67	N 77° 40' 23.15" E		31.00

5/21

REVISIONS

12/21/2011 10:28 AM Internal:V:\design\107 out design

P-109

CIVIL ENGINEER REGISTERED PROFESSIONAL ENGINEER STATE OF MISSISSIPPI NO. 10000	INCOMPLETE PLANS AS PER THE P&M PRELIMINARY PLANS IN ACCORDANCE WITH
---	---



MATCH TO SHEET MIL-04
 STA 12+50.00

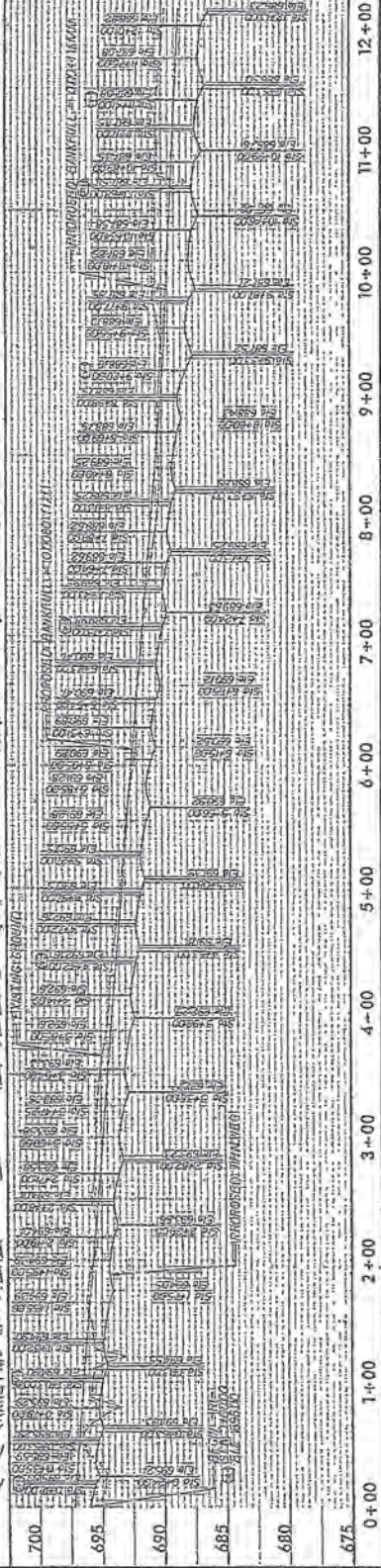

D-420

REVISIONS	

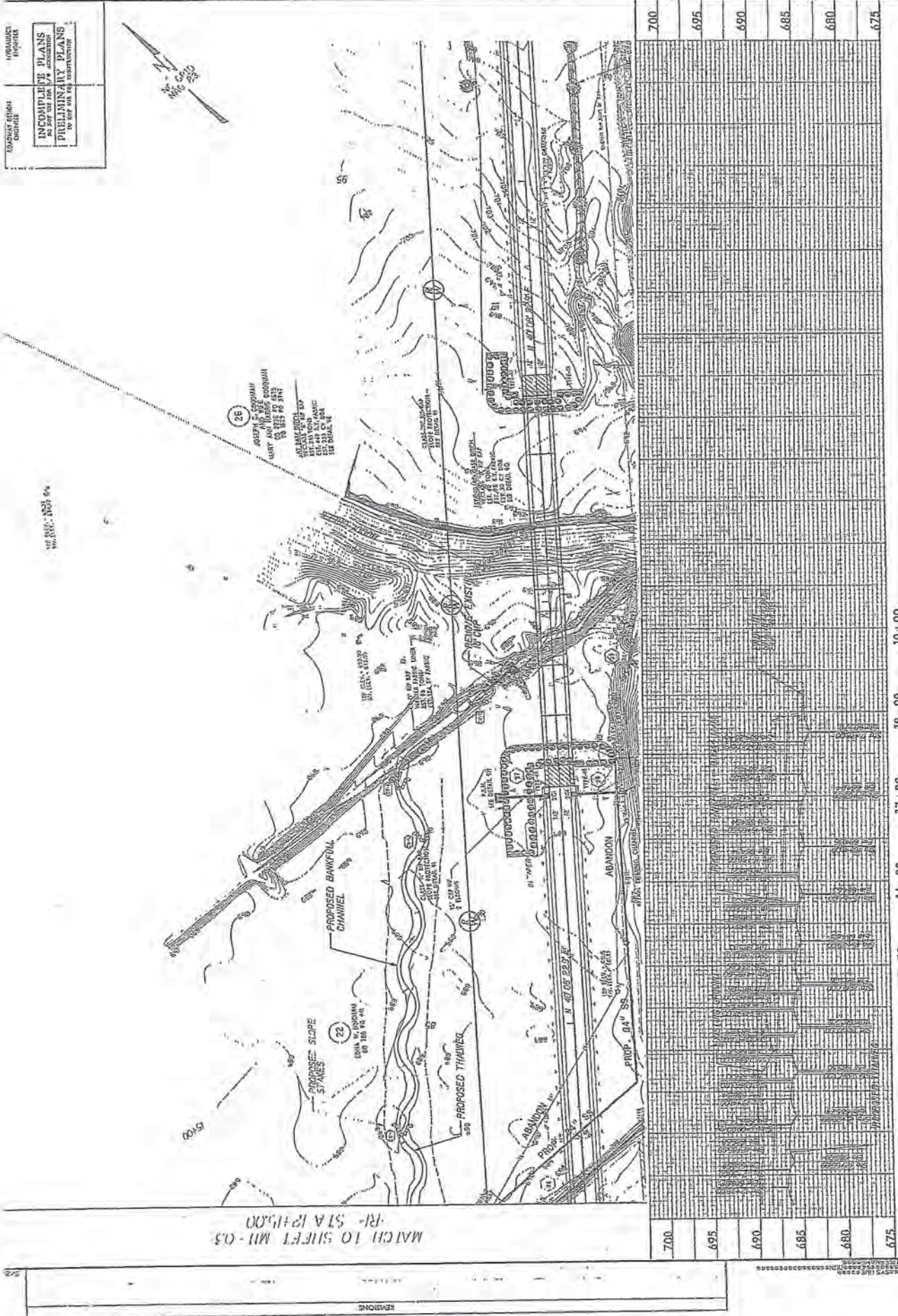

COMPLETE DESIGN
 SHEETS
 INCOMPLETE PLANS
 AS NOTED BY THE ARCHITECT
 PRELIMINARY PLANS
 TO BE FOR THE RECORD



26
 JOSEPH C. COOGLIANT
 CIVIL ENGINEER
 101 N. 1ST ST.
 ST. LOUIS, MO. 63102

THE DIST. NO. 64
 THE DIST. NO. 64

MATCH TO SHEET MI-03
 RI - STA 12+50.00

REVISED

P-111

ALL THESE FIGURES
 INCOMPLETE PLANS
 PRELIMINARY PLANS
 DO NOT USE FOR CONSTRUCTION



MATCH TO SLOTT P.T. 04
-R-1A 12/15/00

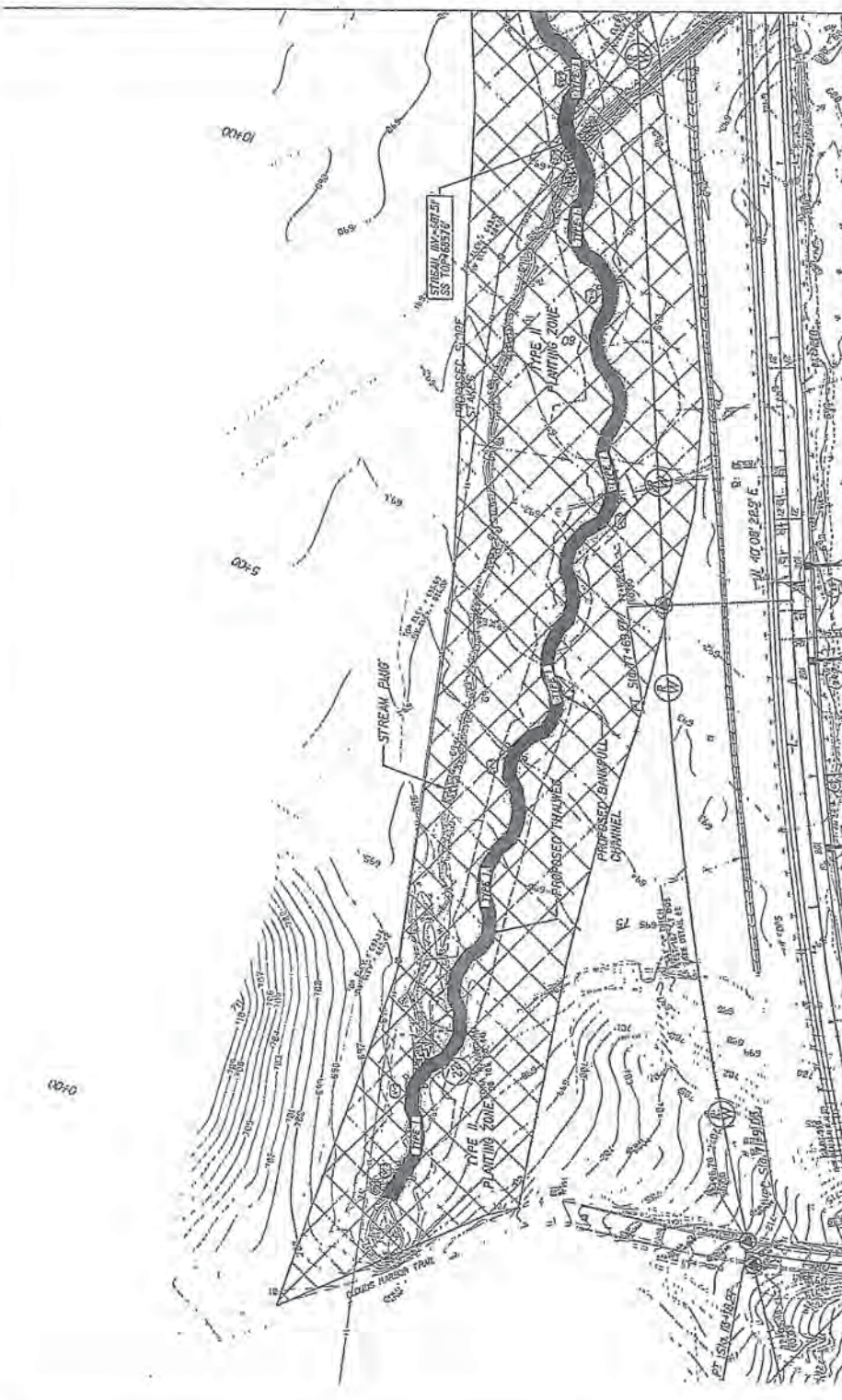

SHEETS
 1" = 100'

P-112

NEW SHEET NO. 110
 ADVANCE SHEET NO. 111
 ADVANCE SHEET NO. 112
 ADVANCE SHEET NO. 113
 ADVANCE SHEET NO. 114
 ADVANCE SHEET NO. 115
 ADVANCE SHEET NO. 116
 ADVANCE SHEET NO. 117
 ADVANCE SHEET NO. 118
 ADVANCE SHEET NO. 119
 ADVANCE SHEET NO. 120



1/8\"/>

MATCH TO SHEET PL-03
 RI - STA 12+50.00

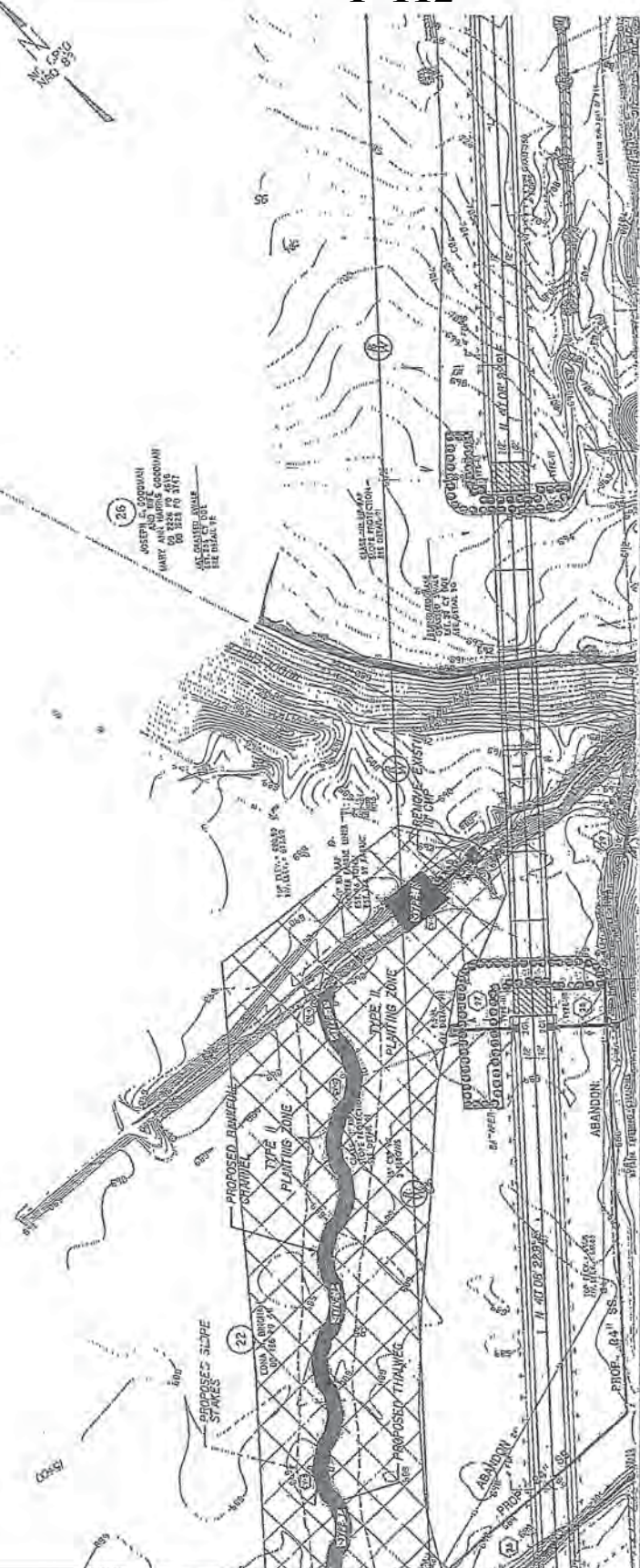

700	12+00	13+00	14+00	15+00	16+00	17+00	18+00	19+00
695								
690								
685								
680								
675								

County : Forsyth

Line #	Item Number	Sec #	Description	Quantity	Unit Cost	Amount
ROADWAY ITEMS						
0001	0000100000-N	800	MOBILIZATION	Lump Sum	L.S.	
0002	0000400000-N	801	CONSTRUCTION SURVEYING	Lump Sum	L.S.	
0003	0001000000-E	200	CLEARING & GRUBBING .. ACRE(S)	Lump Sum	L.S.	
0004	0008000000-E	200	SUPPLEMENTARY CLEARING & GRUB- BING	2 ACR		
0005	0022000000-E	225	UNCLASSIFIED EXCAVATION	71,000 CY		
0006	0029000000-N	SP	REINFORCED BRIDGE APPROACH FILL, STATION ***** (17+35 -Y-)	Lump Sum	L.S.	
0007	0029000000-N	SP	REINFORCED BRIDGE APPROACH FILL, STATION ***** (90+25 -L-)	Lump Sum	L.S.	
0008	0036000000-E	225	UNDERCUT EXCAVATION	1,000 CY		
0009	0106000000-E	230	BORROW EXCAVATION	140,000 CY		
0010	0134000000-E	240	DRAINAGE DITCH EXCAVATION	4,440 CY		
0011	0141000000-E	240	BERM DITCH CONSTRUCTION	240 LF		
0012	0156000000-E	250	REMOVAL OF EXISTING ASPHALT PAVEMENT	1,090 SY		
0013	0192000000-N	260	PROOF ROLLING	20 HR		
0014	0195000000-E	265	SELECT GRANULAR MATERIAL	3,500 CY		
0015	0196000000-E	270	GEOTEXTILE FOR SOIL STABILIZA- TION	5,600 SY		
0016	0318000000-E	300	FOUNDATION CONDITIONING MATE- RIAL, MINOR STRUCTURES	468 TON		
0017	0320000000-E	300	FOUNDATION CONDITIONING GEO- TEXTILE	1,762 SY		
0018	0335200000-E	305	15" DRAINAGE PIPE	1,020 LF		

County : Forsyth

Line #	Item Number	Sec #	Description	Quantity	Unit Cost	Amount
0019	0335300000-E	305	18" DRAINAGE PIPE	88		LF
0020	0335400000-E	305	24" DRAINAGE PIPE	676		LF
0021	0335500000-E	305	30" DRAINAGE PIPE	476		LF
0022	0335800000-E	305	48" DRAINAGE PIPE	416		LF
0023	0344000000-E	310	18" SIDE DRAIN PIPE	88		LF
0024	0448200000-E	310	15" RC PIPE CULVERTS, CLASS IV	144		LF
0025	0582000000-E	310	15" CS PIPE CULVERTS, 0.064" THICK	444		LF
0026	0594000000-E	310	24" CS PIPE CULVERTS, 0.064" THICK	40		LF
0027	0636000000-E	310	*** CS PIPE ELBOWS, ***** THICK (15", 0.064")	22		EA
0028	0636000000-E	310	*** CS PIPE ELBOWS, ***** THICK (24", 0.064")	2		EA
0029	0974000000-E	SP	*** WELDED STEEL PIPE, ***** THICK, GRADE B, (UNDER RR) (36", 0.500")	130		LF
0030	0974000000-E	SP	*** WELDED STEEL PIPE, ***** THICK, GRADE B, (UNDER RR) (48", 0.625")	120		LF
0031	0986000000-E	SP	GENERIC PIPE ITEM 95" X 67" CORRUGATED ALUMINUM ALLOY PIPE ARCH, WITH HEADWALLS	36		LF
0032	0995000000-E	340	PIPE REMOVAL	548		LF
0033	1011000000-N	500	FINE GRADING	Lump Sum	L.S.	
0034	1044000000-E	501	LIME TREATED SOIL (SLURRY METHOD)	27,120		SY
0035	1066000000-E	501	LIME FOR LIME TREATED SOIL	280		TON

County : Forsyth

Line #	Item Number	Sec #	Description	Quantity	Unit Cost	Amount
0036	1077000000-E	SP	#57 STONE	241 TON		
0037	1099500000-E	505	SHALLOW UNDERCUT	850 CY		
0038	1099700000-E	505	CLASS IV SUBGRADE STABILIZATION	1,600 TON		
0039	1110000000-E	510	STABILIZER AGGREGATE	500 TON		
0040	1115000000-E	SP	GEOTEXTILE FOR PAVEMENT STABILIZATION	13,500 SY		
0041	1121000000-E	520	AGGREGATE BASE COURSE	20,500 TON		
0042	1176000000-E	542	SOIL CEMENT BASE	18,080 SY		
0043	1187000000-E	542	PORTLAND CEMENT FOR SOIL CEMENT BASE	498 TON		
0044	1209000000-E	543	ASPHALT CURING SEAL	6,780 GAL		
0045	1220000000-E	545	INCIDENTAL STONE BASE	300 TON		
0046	1275000000-E	600	PRIME COAT	70 GAL		
0047	1308000000-E	607	MILLING ASPHALT PAVEMENT, **** TO ***** (0" TO 1-1/2")	200 SY		
0048	1330000000-E	607	INCIDENTAL MILLING	300 SY		
0049	1489000000-E	610	ASPHALT CONC BASE COURSE, TYPE B25.0B	1,740 TON		
0050	1498000000-E	610	ASPHALT CONC INTERMEDIATE COURSE, TYPE I19.0B	7,400 TON		
0051	1519000000-E	610	ASPHALT CONC SURFACE COURSE, TYPE S9.5B	8,760 TON		
0052	1575000000-E	620	ASPHALT BINDER FOR PLANT MIX	960 TON		
0053	1693000000-E	654	ASPHALT PLANT MIX, PAVEMENT REPAIR	10 TON		

County : Forsyth

Line #	Item Number	Sec #	Description	Quantity	Unit Cost	Amount
0054	2000000000-N	806	RIGHT OF WAY MARKERS	61 EA		
0055	2022000000-E	815	SUBDRAIN EXCAVATION	1,008 CY		
0056	2033000000-E	815	SUBDRAIN FINE AGGREGATE	504 CY		
0057	2044000000-E	815	6" PERFORATED SUBDRAIN PIPE	3,000 LF		
0058	2070000000-N	815	SUBDRAIN PIPE OUTLET	6 EA		
0059	2077000000-E	815	6" OUTLET PIPE	36 LF		
0060	2143000000-E	818	BLOTTING SAND	10 TON		
0061	2209000000-E	838	ENDWALLS	35.6 CY		
0062	2253000000-E	840	PIPE COLLARS	1.013 CY		
0063	2264000000-E	840	PIPE PLUGS	0.09 CY		
0064	2286000000-N	840	MASONRY DRAINAGE STRUCTURES	29 EA		
0065	2308000000-E	840	MASONRY DRAINAGE STRUCTURES	23.32 LF		
0066	2354000000-N	840	FRAME WITH GRATE, STD 840.22	1 EA		
0067	2364000000-N	840	FRAME WITH TWO GRATES, STD 840.16	2 EA		
0068	2365000000-N	840	FRAME WITH TWO GRATES, STD 840.22	1 EA		
0069	2367000000-N	840	FRAME WITH TWO GRATES, STD 840.29	20 EA		
0070	2374000000-N	840	FRAME WITH GRATE & HOOD, STD 840.03, TYPE ** (F)	6 EA		
0071	2451000000-N	852	CONCRETE TRANSITIONAL SECTION FOR DROP INLET	1 EA		
0072	2549000000-E	846	2'-6" CONCRETE CURB & GUTTER	900 LF		

County : Forsyth

Line #	Item Number	Sec #	Description	Quantity	Unit Cost	Amount
0073	2556000000-E	846	SHOULDER BERM GUTTER	1,630		LF
0074	2605000000-N	848	CONCRETE CURB RAMP	10		EA
0075	2612000000-E	848	6" CONCRETE DRIVEWAY	20		SY
0076	2619000000-E	850	4" CONCRETE PAVED DITCH	11		SY
0077	2647000000-E	852	5" MONOLITHIC CONCRETE ISLANDS (SURFACE MOUNTED)	260		SY
0078	3030000000-E	862	STEEL BM GUARDRAIL	4,987.5		LF
0079	3045000000-E	862	STEEL BM GUARDRAIL, SHOP CURVED	162.5		LF
0080	3150000000-N	862	ADDITIONAL GUARDRAIL POSTS	10		EA
0081	3215000000-N	862	GUARDRAIL ANCHOR UNITS, TYPE III	8		EA
0082	3270000000-N	SP	GUARDRAIL ANCHOR UNITS, TYPE 350	10		EA
0083	3628000000-E	876	RIP RAP, CLASS I	365		TON
0084	3642000000-E	876	RIP RAP, CLASS A	25		TON
0085	3649000000-E	876	RIP RAP, CLASS B	1,050		TON
0086	3651000000-E	SP	BOULDERS	732		TON
0087	3656000000-E	876	GEOTEXTILE FOR DRAINAGE	8,980		SY
0088	3659000000-N	SP	PREFORMED SCOUR HOLES WITH LEVEL SPREADER APRON	8		EA
0089	4072000000-E	903	SUPPORTS, 3-LB STEEL U-CHANNEL	565		LF
0090	4096000000-N	904	SIGN ERECTION, TYPE D	5		EA
0091	4102000000-N	904	SIGN ERECTION, TYPE E	20		EA

County : Forsyth

Line #	Item Number	Sec #	Description	Quantity	Unit Cost	Amount
0092	4108000000-N	904	SIGN ERECTION, TYPE F	3	EA	
0093	4155000000-N	907	DISPOSAL OF SIGN SYSTEM, U-CHANNEL	25	EA	
0094	4400000000-E	1110	WORK ZONE SIGNS (STATIONARY)	482	SF	
0095	4405000000-E	1110	WORK ZONE SIGNS (PORTABLE)	394	SF	
0096	4410000000-E	1110	WORK ZONE SIGNS (BARRICADE MOUNTED)	171	SF	
0097	4415000000-N	1115	FLASHING ARROW BOARD	2	EA	
0098	4420000000-N	1120	PORTABLE CHANGEABLE MESSAGE SIGN	4	EA	
0099	4430000000-N	1130	DRUMS	200	EA	
0100	4435000000-N	1135	CONES	200	EA	
0101	4445000000-E	1145	BARRICADES (TYPE III)	152	LF	
0102	4450000000-N	1150	FLAGGER	720	HR	
0103	4480000000-N	1165	TMA	2	EA	
0104	4510000000-N	SP	LAW ENFORCEMENT	80	HR	
0105	4516000000-N	1180	SKINNY DRUM	200	EA	
0106	4650000000-N	1251	TEMPORARY RAISED PAVEMENT MARKERS	311	EA	
0107	4685000000-E	1205	THERMOPLASTIC PAVEMENT MARKING LINES (4", 90 MILS)	25,540	LF	
0108	4686000000-E	1205	THERMOPLASTIC PAVEMENT MARKING LINES (4", 120 MILS)	31,616	LF	
0109	4700000000-E	1205	THERMOPLASTIC PAVEMENT MARKING LINES (12", 90 MILS)	120	LF	
0110	4710000000-E	1205	THERMOPLASTIC PAVEMENT MARKING LINES (24", 120 MILS)	270	LF	

County : Forsyth

Line #	Item Number	Sec #	Description	Quantity	Unit Cost	Amount
0111	4725000000-E	1205	THERMOPLASTIC PAVEMENT MARKING SYMBOL (90 MILS)	40 EA		
0112	4770000000-E	1205	COLD APPLIED PLASTIC PAVEMENT MARKING LINES, TYPE ** (4") (II)	1,405 LF		
0113	4805000000-N	1205	COLD APPLIED PLASTIC PAVEMENT MARKING SYMBOL, TYPE ** (II)	4 EA		
0114	4810000000-E	1205	PAINT PAVEMENT MARKING LINES (4")	16,890 LF		
0115	4825000000-E	1205	PAINT PAVEMENT MARKING LINES (12")	111 LF		
0116	4835000000-E	1205	PAINT PAVEMENT MARKING LINES (24")	100 LF		
0117	4845000000-N	1205	PAINT PAVEMENT MARKING SYMBOL	23 EA		
0118	4900000000-N	1251	PERMANENT RAISED PAVEMENT MARKERS	336 EA		
0119	5326200000-E	1510	12" WATER LINE	40 LF		
0120	5326600000-E	1510	16" WATER LINE	789 LF		
0121	5558000000-E	1515	12" VALVE	1 EA		
0122	5558600000-E	1515	16" VALVE	2 EA		
0123	5572600000-E	1515	16" TAPPING VALVE	1 EA		
0124	5643000000-E	1515	*** WATER METER (5/8")	3 EA		
0125	5648000000-N	1515	RELOCATE WATER METER	3 EA		
0126	5649000000-N	1515	RECONNECT WATER METER	3 EA		
0127	5691900000-E	1520	24" SANITARY GRAVITY SEWER	1,135 LF		
0128	5776000000-E	1525	5' DIA UTILITY MANHOLE	4 EA		

County : Forsyth

Line #	Item Number	Sec #	Description	Quantity	Unit Cost	Amount
0129	5782000000-E	1525	UTILITY MANHOLE WALL, 5' DIA	11.8	LF	
0130	5804000000-E	1530	ABANDON 12" UTILITY PIPE	125	LF	
0131	5810000000-E	1530	ABANDON 16" UTILITY PIPE	528	LF	
0132	5813000000-E	1530	ABANDON 24" UTILITY PIPE	1,052	LF	
0133	5816000000-N	1530	ABANDON UTILITY MANHOLE	3	EA	
0134	5836200000-E	1540	30" ENCASEMENT PIPE	60	LF	
0135	5836400000-E	1540	36" ENCASEMENT PIPE	70	LF	
0136	5872300000-E	1550	TRENCHLESS INSTALLATION OF 30" IN SOIL	30	LF	
0137	5872310000-E	1550	TRENCHLESS INSTALLATION OF 30" NOT IN SOIL	30	LF	
0138	5872400000-E	1550	TRENCHLESS INSTALLATION OF 36" IN SOIL	35	LF	
0139	5872410000-E	1550	TRENCHLESS INSTALLATION OF 36" NOT IN SOIL	35	LF	
0140	6000000000-E	1605	TEMPORARY SILT FENCE	37,400	LF	
0141	6006000000-E	1610	STONE FOR EROSION CONTROL, CLASS A	560	TON	
0142	6009000000-E	1610	STONE FOR EROSION CONTROL, CLASS B	5,785	TON	
0143	6012000000-E	1610	SEDIMENT CONTROL STONE	8,705	TON	
0144	6015000000-E	1615	TEMPORARY MULCHING	46	ACR	
0145	6018000000-E	1620	SEED FOR TEMPORARY SEEDING	2,650	LB	
0146	6021000000-E	1620	FERTILIZER FOR TEMPORARY SEED- ING	14.5	TON	
0147	6024000000-E	1622	TEMPORARY SLOPE DRAINS	3,600	LF	

County : Forsyth

Line #	Item Number	Sec #	Description	Quantity	Unit Cost	Amount
0148	6029000000-E	SP	SAFETY FENCE	4,600	LF	
0149	6030000000-E	1630	SILT EXCAVATION	19,300	CY	
0150	6036000000-E	1631	MATTING FOR EROSION CONTROL	50,000	SY	
0151	6037000000-E	SP	COIR FIBER MAT	230	SY	
0152	6038000000-E	SP	PERMANENT SOIL REINFORCEMENT MAT	445	SY	
0153	6042000000-E	1632	1/4" HARDWARE CLOTH	3,700	LF	
0154	6046000000-E	1636	TEMPORARY PIPE FOR STREAM CROSSING	75	LF	
0155	6070000000-N	1639	SPECIAL STILLING BASINS	37	EA	
0156	6071012000-E	SP	COIR FIBER WATTLE	2,900	LF	
0157	6071020000-E	SP	POLYACRYLAMIDE (PAM)	2,000	LB	
0158	6071030000-E	1640	COIR FIBER BAFFLE	4,000	LF	
0159	6071050000-E	SP	*** SKIMMER (1-1/2")	13	EA	
0160	6071050000-E	SP	*** SKIMMER (2")	6	EA	
0161	6084000000-E	1660	SEEDING & MULCHING	28	ACR	
0162	6087000000-E	1660	MOWING	19	ACR	
0163	6090000000-E	1661	SEED FOR REPAIR SEEDING	500	LB	
0164	6093000000-E	1661	FERTILIZER FOR REPAIR SEEDING	1.75	TON	
0165	6096000000-E	1662	SEED FOR SUPPLEMENTAL SEEDING	975	LB	
0166	6108000000-E	1665	FERTILIZER TOPDRESSING	29.25	TON	
0167	6111000000-E	SP	IMPERVIOUS DIKE	155	LF	

County : Forsyth

Line #	Item Number	Sec #	Description	Quantity	Unit Cost	Amount
0168	6114500000-N	1667	SPECIALIZED HAND MOWING	30	MHR	
0169	6117000000-N	SP	RESPONSE FOR EROSION CONTROL	100	EA	
0170	6123000000-E	1670	REFORESTATION	8	ACR	
0171	6126000000-E	SP	STREAMBANK REFORESTATION	6.81	ACR	
0172	6132000000-N	SP	GENERIC EROSION CONTROL ITEM CONCRETE WASHOUT STRUCTURE	8	EA	
0173	6133000000-N	SP	GENERIC EROSION CONTROL ITEM DIVERSION PUMPING	Lump Sum	L.S.	
0174	6133000000-N	SP	GENERIC EROSION CONTROL ITEM SITE GRADING FOR MITIGATION	Lump Sum	L.S.	
0175	6133000000-N	SP	GENERIC EROSION CONTROL ITEM SURVEYING FOR MITIGATION	Lump Sum	L.S.	
0176	6138000000-E	SP	GENERIC EROSION CONTROL ITEM IMPERVIOUS SELECT MATERIAL	80	CY	
0177	7060000000-E	1705	SIGNAL CABLE	3,450	LF	
0178	7120000000-E	1705	VEHICLE SIGNAL HEAD (12", 3 SECTION)	20	EA	
0179	7132000000-E	1705	VEHICLE SIGNAL HEAD (12", 4 SECTION)	5	EA	
0180	7144000000-E	1705	VEHICLE SIGNAL HEAD (12", 5 SECTION)	1	EA	
0181	7264000000-E	1710	MESSENGER CABLE (3/8")	1,100	LF	
0182	7300000000-E	1715	UNPAVED TRENCHING (***** (1, 2"))	1,150	LF	
0183	7324000000-N	1716	JUNCTION BOX (STANDARD SIZE)	15	EA	
0184	7360000000-N	1720	WOOD POLE	2	EA	
0185	7372000000-N	1721	GUY ASSEMBLY	2	EA	

County : Forsyth

Line #	Item Number	Sec #	Description	Quantity	Unit Cost	Amount
0186	7420000000-E	1722	2" RISER WITH WEATHERHEAD	2 EA		
0187	7444000000-E	1725	INDUCTIVE LOOP SAWCUT	2,750 LF		
0188	7456000000-E	1726	LEAD-IN CABLE (***** (14-2)	5,850 LF		
0189	7576000000-N	SP	METAL STRAIN SIGNAL POLE	8 EA		
0190	7613000000-N	SP	SOIL TEST	8 EA		
0191	7614100000-E	SP	DRILLED PIER FOUNDATION	48 CY		
0192	7636000000-N	1745	SIGN FOR SIGNALS	2 EA		
0193	7684000000-N	1750	SIGNAL CABINET FOUNDATION	2 EA		
0194	7756000000-N	1751	CONTROLLER WITH CABINET (TYPE 2070L, BASE MOUNTED)	2 EA		
0195	7780000000-N	1751	DETECTOR CARD (TYPE 2070L)	14 EA		

STRUCTURE ITEMS

0196	8035000000-N	402	REMOVAL OF EXISTING STRUCTURE AT STATION ***** (17+34.88 -Y-)	Lump Sum	L.S.	
0197	8091000000-N	410	FOUNDATION EXCAVATION FOR BENT ** AT STATION ***** (1, 17+34.88 -Y-)	Lump Sum	L.S.	
0198	8091000000-N	410	FOUNDATION EXCAVATION FOR BENT ** AT STATION ***** (2, 17+34.88 -Y-)	Lump Sum	L.S.	
0199	8096000000-E	450	PILE EXCAVATION IN SOIL	276 LF		
0200	8097000000-E	450	PILE EXCAVATION NOT IN SOIL	44 LF		
0201	8105540000-E	411	3'-6" DIA DRILLED PIERS IN SOIL	226 LF		

County : Forsyth

Line #	Item Number	Sec #	Description	Quantity	Unit Cost	Amount
0202	8105640000-E	411	3'-6" DIA DRILLED PIERS NOT IN SOIL	67 LF		
0203	8111400000-E	411	PERMANENT STEEL CASING FOR 3'-6" DIA DRILLED PIER	45.8 LF		
0204	8113000000-N	411	SID INSPECTIONS	10 EA		
0205	8114000000-N	411	SPT TESTING	10 EA		
0206	8115000000-N	411	CSL TESTING	5 EA		
0207	8121000000-N	412	UNCLASSIFIED STRUCTURE EXCAVATION AT STATION ***** (17+34.88 -Y-)	Lump Sum	L.S.	
0208	8147000000-E	420	REINFORCED CONCRETE DECK SLAB	30,502 SF		
0209	8161000000-E	420	GROOVING BRIDGE FLOORS	28,448 SF		
0210	8182000000-E	420	CLASS A CONCRETE (BRIDGE)	608.3 CY		
0211	8210000000-N	422	BRIDGE APPROACH SLABS, STATION ***** (17+34.88 -Y-)	Lump Sum	L.S.	
0212	8210000000-N	422	BRIDGE APPROACH SLABS, STATION ***** (90+25.00 -L-)	Lump Sum	L.S.	
0213	8217000000-E	425	REINFORCING STEEL (BRIDGE)	167,527 LB		
0214	8238000000-E	425	SPIRAL COLUMN REINFORCING STEEL (BRIDGE)	14,580 LB		
0215	8265000000-E	430	54" PRESTRESSED CONCRETE GIRDERS	3,471.93 LF		
0216	8364000000-E	450	HP12X53 STEEL PILES	4,660 LF		
0217	8391000000-N	450	STEEL PILE POINTS	32 EA		
0218	8475000000-E	460	TWO BAR METAL RAIL	1,357 LF		
0219	8517000000-E	460	1'-***"X ***** CONCRETE PARAPET (1'-2" X 2'-6")	1,387 LF		

County : Forsyth

Line #	Item Number	Sec #	Description	Quantity	Unit Cost	Amount
0220	8524000000-E	SP	*** CHAIN LINK FENCE (72")	406.7 LF		
0221	8531000000-E	462	4" SLOPE PROTECTION	1,131 SY		
0222	8608000000-E	876	RIP RAP CLASS II (2'-0" THICK)	1,517 TON		
0223	8622000000-E	876	GEOTEXTILE FOR DRAINAGE	1,685 SY		
0224	8657000000-N	430	ELASTOMERIC BEARINGS	Lump Sum	L.S.	
0225	8692000000-N	SP	FOAM JOINT SEALS	Lump Sum	L.S.	
0226	8706000000-N	SP	EXPANSION JOINT SEALS	Lump Sum	L.S.	
0227	8860000000-N	SP	GENERIC STRUCTURE ITEM ASBESTOS ASSESSMENT	Lump Sum	L.S.	

1613/Mar02/Q871395.063/D1017285362000/E227

Total Amount Of Bid For Entire Project :

Vendor 1 of 8: SMITH-ROWE, LLC (9965)
Call Order 003 (Proposal: C203725)

Bid Information

Proposal County: FORSYTH	Bid Checksum: CADCE515
Vendor Address: 639 Old US 52 South Mount Airy , NC , 27030	Bid Total: \$11,693,639.31
Signature Check: William_F._Fulp_9965	Items Total: \$11,693,639.31
Time Bid Received: April 19, 2016 01:53 PM	Time Total: \$0.00
Amendment Count: 0	

Bidding Errors:

DBE Warning : MBE Warning: MBE Commitment Goal not met

MBE GOAL SET 4.0
MBE GOAL OBT. 1.9
WBE GOAL SET 6.0
WBE GOAL MET 6.0

Vendor 1 of 8: SMITH-ROWE, LLC (9965)
Call Order 003 (Proposal: C203725)

Bid Bond Information

Projects:	Bond Maximum:
Counties:	State of Incorporation:
Bond ID: SNC16989917	Agency Execution Date: 4/15/2016 8
Paid by Check: No	Surety Name: surety2000
Bond Percent: 5%	Bond Agency Name: Travelers Casualty and Surety Company of America

Bidder 1 of 8

Vendor 9965's Bid Information for Call 003, Letting L160419, 04/19/16

Smith-Rowe, LLC (9965)
Call Order 003 (Proposal ID C203725)

LIST OF MBE PARTICIPANTS

VENDOR NUMBER	DBE NAME ADDRESS	WORK CODE TYPE OF WORK	CERT TYPE AMOUNT	
9602 MB	CAROLINA TRANSPORT OF GREENSBOR 347 SOUTH CHERRY STREET , KERNERSVILLE, NC 27284		Sub 150,000.00	Committed
12289 MB	SMITH JAMISON DBA SMITH JAMISON 4015 PENDORIC CIRCLE , WINSTON-SALEM, NC 27106		Sub 67,956.00	Committed
			TOTAL: \$217,956.00	1.86%

Vendor 9965's Bid Information for Call 003, Letting L160419, 04/19/16

Smith-Rowe, LLC (9965)
Call Order 003 (Proposal ID C203725)

LIST OF WBE PARTICIPANTS

VENDOR NUMBER	DBE NAME ADDRESS	WORK CODE TYPE OF WORK	CERT TYPE AMOUNT	
12802 WB	NICKELSTON INDUSTRIES, INC. POST OFFICE BOX 133 , LAWSONVILLE, NC 27022		Sub 99,337.50	Committed
11402 WB	FLORENCE CONCRETE PRODUCTS, INC P.O. BOX 5506 , FLORENCE, SC 295025506		Man 460,412.64	Committed
3230 WB	HIATT & MASON ENTERPRISES INC POST OFFICE BOX 1378 , MOUNT AIRY, NC 27030		Sub 62,529.10	Committed
4761 WB	TRAFFIC CONTROL SAFETY SERVICES POST OFFICE BOX 24511 , WINSTON-SALEM, NC 27114		Sub 10,923.50	Committed
3418 WB	NORTH STATE ENVIRONMENTAL, INC 2889 LOWERY STREET, SUITE B , WINSTON-SALEM, NC 271016127		Sub 78,441.43	Committed
4434 WB	LONG BROTHERS OF SUMMERFIELD, I PO BOX 35048 , GREENSBORO, NC 27425		Sub 105,000.00	Committed
			TOTAL: \$816,644.17	6.98%

Vendor 9965's Bid Information for Call 003, Letting L160419, 04/19/16

Smith-Rowe, LLC (9965)
Call Order 003 (Proposal ID C203725)

Miscellaneous Data Info - Contractor Responses:
=====

NON-COLLUSION AND DEBARMENT CERTIFICATION

Explanation of the prospective bidder that is unable to certify to any of the statements in this certification:

Explanation:
NOT ANSWERED
NOT ANSWERED
NOT ANSWERED
NOT ANSWERED

Bidder 1 of 8

AWARD LIMITS ON MULTIPLE PROJECTS

By answering YES to this statement, the bidder acknowledges that they are using the award limits on multiple projects. No

It is the desire of the Bidder to be awarded contracts, the value of which will not exceed a total of NOT ANSWERED for those projects indicated herein, for which bids will be opened on (MM/DD/YY)

The Award Limits shall apply to the following projects:

Contract Number	County
NOT ANSWERED	
NOT ANSWERED	
NOT ANSWERED	
NOT ANSWERED	
NOT ANSWERED	
NOT ANSWERED	

Bid Bond Data Info - Contractor Responses:

=====

BondID: SNC16989917
 Surety Registry Agency: surety2000
 Verified?: Yes
 Surety Agency: Travelers Casualty and Surety Company of America
 Bond Execution Date: 4/15/2016 8
 Bond Amount: \$584,681.97 (Five Percent of Bid)

Contract ID: C203725

Project(s): STATE FUNDED

Letting Date: 04-19-16 Call Order: 003

Bidder: 9965 - Smith-Rowe, LLC

Line No.	Item Description	Approx. Quantity and Units	Unit Price Dollars Cts	Bid Amount Dollars Ct
Section 0001 ROADWAY ITEMS				
Alt Group				
0001	0000100000-N MOBILIZATION	LUMP	LUMP	584,500.00
0002	0000400000-N CONSTRUCTION SURVEYING	LUMP	LUMP	66,650.00
0003	0001000000-E CLEARING & GRUBBING .. ACRE(S)	LUMP	LUMP	805,300.00
0004	0008000000-E SUPPLEMENTARY CLEARING & GRUBBING	2.000 ACR	1.00000	2.00
0005	0022000000-E UNCLASSIFIED EXCAVATION	71,000.000 CY	4.32000	306,720.00
0006	0029000000-N REINFORCED BRIDGE APPROACH FILL, STATION ***** (17+35 -Y-)	LUMP	LUMP	79,400.00
0007	0029000000-N REINFORCED BRIDGE APPROACH FILL, STATION ***** (90+25 -L-)	LUMP	LUMP	34,725.00
0008	0036000000-E UNDERCUT EXCAVATION	1,000.000 CY	12.50000	12,500.00
0009	0106000000-E BORROW EXCAVATION	140,000.000 CY	5.60000	784,000.00
0010	0134000000-E DRAINAGE DITCH EXCAVATION	4,440.000 CY	5.35000	23,754.00

Dept of Transportation

Revised:

Contract ID: C203725

Project(s): STATE FUNDED

Letting Date: 04-19-16 Call Order: 003

Bidder: 9965 - Smith-Rowe, LLC

Line No.	Item Description	Approx. Quantity and Units	Unit Price Dollars Cts	Bid Amount Dollars Ct
0011	0141000000-E BERM DITCH CONSTRUCTION	240.000	4.50000	1,080.00
		LF		
0012	0156000000-E REMOVAL OF EXISTING ASPHALT PAVEMENT	1,090.000	5.65000	6,158.50
		SY		
0013	0192000000-N PROOF ROLLING	20.000	250.00000	5,000.00
		HR		
0014	0195000000-E SELECT GRANULAR MATERIAL	3,500.000	15.00000	52,500.00
		CY		
0015	0196000000-E GEOTEXTILE FOR SOIL STABILIZATION	5,600.000	2.05000	11,480.00
		SY		
0016	0318000000-E FOUNDATION CONDITIONING MATERIAL, MINOR STRUCTURES	468.000	34.00000	15,912.00
		TON		
0017	0320000000-E FOUNDATION CONDITIONING GEOTEXTILE	1,762.000	3.00000	5,286.00
		SY		
0018	0335200000-E 15" DRAINAGE PIPE	1,020.000	36.50000	37,230.00
		LF		
0019	0335300000-E 18" DRAINAGE PIPE	88.000	43.75000	3,850.00
		LF		
0020	0335400000-E 24" DRAINAGE PIPE	676.000	54.75000	37,011.00
		LF		
0021	0335500000-E 30" DRAINAGE PIPE	476.000	72.00000	34,272.00
		LF		
0022	0335800000-E 48" DRAINAGE PIPE	416.000	103.00000	42,848.00
		LF		

Dept of Transportation

Revised:

Contract ID: C203725

Project(s): STATE FUNDED

Letting Date: 04-19-16 Call Order: 003

Bidder: 9965 - Smith-Rowe, LLC

Line No.	Item Description	Approx. Quantity and Units	Unit Price Dollars Cts	Bid Amount Dollars Ct
0023	0344000000-E 18" SIDE DRAIN PIPE	88.000	43.75000	3,850.00
		LF		
0024	0448200000-E 15" RC PIPE CULVERTS, CLASS IV	144.000	46.00000	6,624.00
		LF		
0025	0582000000-E 15" CS PIPE CULVERTS, 0.064" THICK	444.000	62.50000	27,750.00
		LF		
0026	0594000000-E 24" CS PIPE CULVERTS, 0.064" THICK	40.000	57.75000	2,310.00
		LF		
0027	0636000000-E **" CS PIPE ELBOWS, ***** THICK (15", 0.064")	22.000	150.00000	3,300.00
		EA		
0028	0636000000-E **" CS PIPE ELBOWS, ***** THICK (24", 0.064")	2.000	200.00000	400.00
		EA		
0029	0974000000-E **" WELDED STEEL PIPE, ***** THICK, GRADE B, (UNDER RR) (36", 0.500")	130.000	465.00000	60,450.00
		LF		
0030	0974000000-E **" WELDED STEEL PIPE, ***** THICK, GRADE B, (UNDER RR) (48", 0.625")	120.000	650.00000	78,000.00
		LF		
0031	0986000000-E GENERIC PIPE ITEM 95" X 67" CORRUGATED ALUMINUM ALLOY PIPE ARCH, WITH HEADWALLS	36.000	2,550.00000	91,800.00
		LF		
0032	0995000000-E PIPE REMOVAL	548.000	15.50000	8,494.00
		LF		
0033	1011000000-N FINE GRADING	LUMP	LUMP	448,411.00

Dept of Transportation

Revised:

Contract ID: C203725

Project(s): STATE FUNDED

Letting Date: 04-19-16 Call Order: 003

Bidder: 9965 - Smith-Rowe, LLC

Line No.	Item Description	Approx. Quantity and Units	Unit Price Dollars Cts	Bid Amount Dollars Ct
0034	1044000000-E LIME TREATED SOIL (SLURRY METHOD)	27,120.000 SY	3.35000	90,852.00
0035	1066000000-E LIME FOR LIME TREATED SOIL	280.000 TON	217.00000	60,760.00
0036	1077000000-E #57 STONE	241.000 TON	35.00000	8,435.00
0037	1099500000-E SHALLOW UNDERCUT	850.000 CY	10.41000	8,848.50
0038	1099700000-E CLASS IV SUBGRADE STABILIZATION	1,600.000 TON	27.25000	43,600.00
0039	1110000000-E STABILIZER AGGREGATE	500.000 TON	29.90000	14,950.00
0040	1115000000-E GEOTEXTILE FOR PAVEMENT STABILIZATION	13,500.000 SY	2.25000	30,375.00
0041	1121000000-E AGGREGATE BASE COURSE	20,500.000 TON	23.50000	481,750.00
0042	1176000000-E SOIL CEMENT BASE	18,080.000 SY	2.45000	44,296.00
0043	1187000000-E PORTLAND CEMENT FOR SOIL CEMENT BASE	498.000 TON	169.00000	84,162.00
0044	1209000000-E ASPHALT CURING SEAL	6,780.000 GAL	5.00000	33,900.00
0045	1220000000-E INCIDENTAL STONE BASE	300.000 TON	50.00000	15,000.00

Dept of Transportation

Revised:

Contract ID: C203725

Project(s): STATE FUNDED

Letting Date: 04-19-16 Call Order: 003

Bidder: 9965 - Smith-Rowe, LLC

Line No.	Item Description	Approx. Quantity and Units	Unit Price Dollars Cts	Bid Amount Dollars Ct
0046	1275000000-E PRIME COAT GAL	70.000	3.25000	227.50
0047	1308000000-E MILLING ASPHALT PAVEMENT, ***"TO *****" (0" TO 1-1/2") SY	200.000	22.00000	4,400.00
0048	1330000000-E INCIDENTAL MILLING SY	300.000	22.00000	6,600.00
0049	1489000000-E ASPHALT CONC BASE COURSE, TYPE B25.0B TON	1,740.000	61.45000	106,923.00
0050	1498000000-E ASPHALT CONC INTERMEDIATE COURSE, TYPE I19.0B TON	7,400.000	46.16000	341,584.00
0051	1519000000-E ASPHALT CONC SURFACE COURSE, TYPE S9.5B TON	8,760.000	48.05000	420,918.00
0052	1575000000-E ASPHALT BINDER FOR PLANT MIX TON	960.000	300.00000	288,000.00
0053	1693000000-E ASPHALT PLANT MIX, PAVEMENT REPAIR TON	10.000	400.00000	4,000.00
0054	2000000000-N RIGHT OF WAY MARKERS EA	61.000	158.95000	9,695.95
0055	2022000000-E SUBDRAIN EXCAVATION CY	1,008.000	10.00000	10,080.00
0056	2033000000-E SUBDRAIN FINE AGGREGATE CY	504.000	35.00000	17,640.00
0057	2044000000-E 6" PERFORATED SUBDRAIN PIPE LF	3,000.000	5.00000	15,000.00

Dept of Transportation

Revised:

Contract ID: C203725

Project(s): STATE FUNDED

Letting Date: 04-19-16 Call Order: 003

Bidder: 9965 - Smith-Rowe, LLC

Line No.	Item Description	Approx. Quantity and Units	Unit Price Dollars Cts	Bid Amount Dollars Ct
0058	2070000000-N SUBDRAIN PIPE OUTLET	6.000 EA	100.00000	600.00
0059	2077000000-E 6" OUTLET PIPE	36.000 LF	15.00000	540.00
0060	2143000000-E BLOTTING SAND	10.000 TON	35.00000	350.00
0061	2209000000-E ENDWALLS	35.600 CY	1,050.00000	37,380.00
0062	2253000000-E PIPE COLLARS	1.013 CY	2,171.69000	2,199.92
0063	2264000000-E PIPE PLUGS	0.090 CY	3,558.09000	320.23
0064	2286000000-N MASONRY DRAINAGE STRUCTURES	29.000 EA	1,195.00000	34,655.00
0065	2308000000-E MASONRY DRAINAGE STRUCTURES	23.320 LF	221.50000	5,165.38
0066	2354000000-N FRAME WITH GRATE, STD 840.22	1.000 EA	930.15000	930.15
0067	2364000000-N FRAME WITH TWO GRATES, STD 840.16	2.000 EA	1,150.00000	2,300.00
0068	2365000000-N FRAME WITH TWO GRATES, STD 840.22	1.000 EA	1,050.00000	1,050.00
0069	2367000000-N FRAME WITH TWO GRATES, STD 840.29	20.000 EA	500.00000	10,000.00

Dept of Transportation

Revised:

Contract ID: C203725

Project(s): STATE FUNDED

Letting Date: 04-19-16 Call Order: 003

Bidder: 9965 - Smith-Rowe, LLC

Line No.	Item Description	Approx. Quantity and Units	Unit Price Dollars Cts	Bid Amount Dollars Ct
0070	2374000000-N FRAME WITH GRATE & HOOD, STD 1840.03, TYPE ** (F)	6.000 EA	600.00000	3,600.00
0071	2451000000-N CONCRETE TRANSITIONAL SECTION FOR DROP INLET	1.000 EA	1,032.00000	1,032.00
0072	2549000000-E 2'-6" CONCRETE CURB & GUTTER	900.000 LF	13.75000	12,375.00
0073	2556000000-E SHOULDER BERM GUTTER	1,630.000 LF	17.25000	28,117.50
0074	2605000000-N CONCRETE CURB RAMP	10.000 EA	1,225.00000	12,250.00
0075	2612000000-E 6" CONCRETE DRIVEWAY	20.000 SY	90.00000	1,800.00
0076	2619000000-E 4" CONCRETE PAVED DITCH	11.000 SY	36.50000	401.50
0077	2647000000-E 5" MONOLITHIC CONCRETE ISLANDS (SURFACE MOUNTED)	260.000 SY	42.50000	11,050.00
0078	3030000000-E STEEL BM GUARDRAIL	4,987.500 LF	13.50000	67,331.25
0079	3045000000-E STEEL BM GUARDRAIL, SHOP CURVED	162.500 LF	14.50000	2,356.25
0080	3150000000-N ADDITIONAL GUARDRAIL POSTS	10.000 EA	1.00000	10.00
0081	3215000000-N GUARDRAIL ANCHOR UNITS, TYPE III	8.000 EA	1,550.00000	12,400.00

Dept of Transportation

Revised:

Contract ID: C203725

Project(s): STATE FUNDED

Letting Date: 04-19-16 Call Order: 003

Bidder: 9965 - Smith-Rowe, LLC

Line No.	Item Description	Approx. Quantity and Units	Unit Price Dollars Cts	Bid Amount Dollars Ct
0082	3270000000-N GUARDRAIL ANCHOR UNITS, TYPE 350	10.000 EA	1,700.00000	17,000.00
0083	3628000000-E RIP RAP, CLASS I	365.000 TON	43.35000	15,822.75
0084	3642000000-E RIP RAP, CLASS A	25.000 TON	40.50000	1,012.50
0085	3649000000-E RIP RAP, CLASS B	1,050.000 TON	36.00000	37,800.00
0086	3651000000-E BOULDERS	732.000 TON	65.00000	47,580.00
0087	3656000000-E GEOTEXTILE FOR DRAINAGE	8,980.000 SY	2.17000	19,486.60
0088	3659000000-N PREFORMED SCOUR HOLES WITH LEVEL SPREADER APRON	8.000 EA	1,265.00000	10,120.00
0089	4072000000-E SUPPORTS, 3-LB STEEL U-CHANNEL	565.000 LF	5.50000	3,107.50
0090	4096000000-N SIGN ERECTION, TYPE D	5.000 EA	95.00000	475.00
0091	4102000000-N SIGN ERECTION, TYPE E	20.000 EA	55.00000	1,100.00
0092	4108000000-N SIGN ERECTION, TYPE F	3.000 EA	95.00000	285.00
0093	4155000000-N DISPOSAL OF SIGN SYSTEM, U-CHANNEL	25.000 EA	1.00000	25.00

Dept of Transportation

Revised:

Contract ID: C203725

Project(s): STATE FUNDED

Letting Date: 04-19-16 Call Order: 003

Bidder: 9965 - Smith-Rowe, LLC

Line No.	Item Description	Approx. Quantity and Units	Unit Price Dollars Cts	Bid Amount Dollars Ct
0094	4400000000-E WORK ZONE SIGNS (STATIONARY)	482.000	4.50000	2,169.00
		SF		
0095	4405000000-E WORK ZONE SIGNS (PORTABLE)	394.000	13.35000	5,259.90
		SF		
0096	4410000000-E WORK ZONE SIGNS (BARRICADE MOUNTED)	171.000	6.00000	1,026.00
		SF		
0097	4415000000-N FLASHING ARROW BOARD	2.000	2,050.00000	4,100.00
		EA		
0098	4420000000-N PORTABLE CHANGEABLE MESSAGE SIGN	4.000	4,775.00000	19,100.00
		EA		
0099	4430000000-N DRUMS	200.000	63.75000	12,750.00
		EA		
0100	4435000000-N CONES	200.000	32.35000	6,470.00
		EA		
0101	4445000000-E BARRICADES (TYPE III)	152.000	18.00000	2,736.00
		LF		
0102	4450000000-N FLAGGER	720.000	26.00000	18,720.00
		HR		
0103	4480000000-N TMA	2.000	1,000.00000	2,000.00
		EA		
0104	4510000000-N LAW ENFORCEMENT	80.000	47.25000	3,780.00
		HR		
0105	4516000000-N SKINNY DRUM	200.000	15.00000	3,000.00
		EA		

Dept of Transportation

Revised:

Contract ID: C203725

Project(s): STATE FUNDED

Letting Date: 04-19-16 Call Order: 003

Bidder: 9965 - Smith-Rowe, LLC

Line No.	Item Description	Approx. Quantity and Units	Unit Price Dollars Cts	Bid Amount Dollars Ct
0106	4650000000-N TEMPORARY RAISED PAVEMENT MARKERS	311.000 EA	12.00000	3,732.00
0107	4685000000-E THERMOPLASTIC PAVEMENT MARKING LINES (4", 90 MILS)	25,540.000 LF	0.64000	16,345.60
0108	4686000000-E THERMOPLASTIC PAVEMENT MARKING LINES (4", 120 MILS)	31,616.000 LF	0.74000	23,395.84
0109	4700000000-E THERMOPLASTIC PAVEMENT MARKING LINES (12", 90 MILS)	120.000 LF	4.50000	540.00
0110	4710000000-E THERMOPLASTIC PAVEMENT MARKING LINES (24", 120 MILS)	270.000 LF	12.25000	3,307.50
0111	4725000000-E THERMOPLASTIC PAVEMENT MARKING SYMBOL (90 MILS)	40.000 EA	100.00000	4,000.00
0112	4770000000-E COLD APPLIED PLASTIC PAVEMENT MARKING LINES, TYPE ** (4") (II)	1,405.000 LF	2.65000	3,723.25
0113	4805000000-N COLD APPLIED PLASTIC PAVEMENT MARKING SYMBOL, TYPE ** (II)	4.000 EA	1,100.00000	4,400.00
0114	4810000000-E PAINT PAVEMENT MARKING LINES (4")	16,890.000 LF	0.32000	5,404.80
0115	4825000000-E PAINT PAVEMENT MARKING LINES (12")	111.000 LF	3.00000	333.00
0116	4835000000-E PAINT PAVEMENT MARKING LINES (24")	100.000 LF	4.00000	400.00

Dept of Transportation

Revised:

Contract ID: C203725

Project(s): STATE FUNDED

Letting Date: 04-19-16 Call Order: 003

Bidder: 9965 - Smith-Rowe, LLC

Line No.	Item Description	Approx. Quantity and Units	Unit Price Dollars Cts	Bid Amount Dollars Ct
0117	4845000000-N PAINT PAVEMENT MARKING SYMBOL	23.000 EA	75.00000	1,725.00
0118	4900000000-N PERMANENT RAISED PAVEMENT MARKERS	336.000 EA	12.00000	4,032.00
0119	5326200000-E 12" WATER LINE	40.000 LF	277.15000	11,086.00
0120	5326600000-E 16" WATER LINE	789.000 LF	131.07000	103,414.23
0121	5558000000-E 12" VALVE	1.000 EA	2,847.55000	2,847.55
0122	5558600000-E 16" VALVE	2.000 EA	7,877.45000	15,754.90
0123	5572600000-E 16" TAPPING VALVE	1.000 EA	27,165.91000	27,165.91
0124	5643000000-E ***" WATER METER (5/8")	3.000 EA	1,654.16000	4,962.48
0125	5648000000-N RELOCATE WATER METER	3.000 EA	1,654.16000	4,962.48
0126	5649000000-N RECONNECT WATER METER	3.000 EA	1,654.16000	4,962.48
0127	5691900000-E 24" SANITARY GRAVITY SEWER	1,135.000 LF	197.17000	223,787.95
0128	5776000000-E 5' DIA UTILITY MANHOLE	4.000 EA	5,544.39000	22,177.56

Dept of Transportation

Revised:

Contract ID: C203725

Project(s): STATE FUNDED

Letting Date: 04-19-16 Call Order: 003

Bidder: 9965 - Smith-Rowe, LLC

Line No.	Item Description	Approx. Quantity and Units	Unit Price Dollars Cts	Bid Amount Dollars Ct
0129	5782000000-E UTILITY MANHOLE WALL, 5' DIA	11.800	131.80000	1,555.24
		LF		
0130	5804000000-E ABANDON 12" UTILITY PIPE	125.000	8.48000	1,060.00
		LF		
0131	5810000000-E ABANDON 16" UTILITY PIPE	528.000	12.24000	6,462.72
		LF		
0132	5813000000-E ABANDON 24" UTILITY PIPE	1,052.000	24.09000	25,342.68
		LF		
0133	5816000000-N ABANDON UTILITY MANHOLE	3.000	1,299.05000	3,897.15
		EA		
0134	5836200000-E 30" ENCASEMENT PIPE	60.000	495.51000	29,730.60
		LF		
0135	5836400000-E 36" ENCASEMENT PIPE	70.000	508.88000	35,621.60
		LF		
0136	5872300000-E TRENCHLESS INSTALLATION OF 30"IN SOIL	30.000	950.68000	28,520.40
		LF		
0137	5872310000-E TRENCHLESS INSTALLATION OF 30"NOT IN SOIL	30.000	1,192.43000	35,772.90
		LF		
0138	5872400000-E TRENCHLESS INSTALLATION OF 36"IN SOIL	35.000	283.10000	9,908.50
		LF		
0139	5872410000-E TRENCHLESS INSTALLATION OF 36"NOT IN SOIL	35.000	673.20000	23,562.00
		LF		
0140	6000000000-E TEMPORARY SILT FENCE	37,400.000	1.55000	57,970.00
		LF		

Dept of Transportation

Revised:

Contract ID: C203725

Project(s): STATE FUNDED

Letting Date: 04-19-16 Call Order: 003

Bidder: 9965 - Smith-Rowe, LLC

Line No.	Item Description	Approx. Quantity and Units	Unit Price Dollars Cts	Bid Amount Dollars Ct
0141	6006000000-E STONE FOR EROSION CONTROL, CLASS A	560.000 TON	50.00000	28,000.00
0142	6009000000-E STONE FOR EROSION CONTROL, CLASS B	5,785.000 TON	25.00000	144,625.00
0143	6012000000-E SEDIMENT CONTROL STONE	8,705.000 TON	22.75000	198,038.75
0144	6015000000-E TEMPORARY MULCHING	46.000 ACR	1,500.00000	69,000.00
0145	6018000000-E SEED FOR TEMPORARY SEEDING	2,650.000 LB	0.25000	662.50
0146	6021000000-E FERTILIZER FOR TEMPORARY SEED-ING	14.500 TON	100.00000	1,450.00
0147	6024000000-E TEMPORARY SLOPE DRAINS	3,600.000 LF	10.00000	36,000.00
0148	6029000000-E SAFETY FENCE	4,600.000 LF	2.50000	11,500.00
0149	6030000000-E SILT EXCAVATION	19,300.000 CY	2.00000	38,600.00
0150	6036000000-E MATTING FOR EROSION CONTROL	50,000.000 SY	1.24000	62,000.00
0151	6037000000-E COIR FIBER MAT	230.000 SY	15.00000	3,450.00
0152	6038000000-E PERMANENT SOIL REINFORCEMENT MAT	445.000 SY	13.50000	6,007.50

Dept of Transportation

Revised:

Contract ID: C203725

Project(s): STATE FUNDED

Letting Date: 04-19-16 Call Order: 003

Bidder: 9965 - Smith-Rowe, LLC

Line No.	Item Description	Approx. Quantity and Units	Unit Price Dollars Cts	Bid Amount Dollars Ct
0153	6042000000-E 1/4" HARDWARE CLOTH	3,700.000	3.00000	11,100.00
		LF		
0154	6046000000-E TEMPORARY PIPE FOR STREAM CROSSING	75.000	50.00000	3,750.00
		LF		
0155	6070000000-N SPECIAL STILLING BASINS	37.000	90.00000	3,330.00
		EA		
0156	6071012000-E COIR FIBER WATTLE	2,900.000	6.50000	18,850.00
		LF		
0157	6071020000-E POLYACRYLAMIDE (PAM)	2,000.000	1.00000	2,000.00
		LB		
0158	6071030000-E COIR FIBER BAFFLE	4,000.000	4.50000	18,000.00
		LF		
0159	6071050000-E *** SKIMMER (1-1/2")	13.000	940.00000	12,220.00
		EA		
0160	6071050000-E *** SKIMMER (2")	6.000	1,085.00000	6,510.00
		EA		
0161	6084000000-E SEEDING & MULCHING	28.000	1,600.00000	44,800.00
		ACR		
0162	6087000000-E MOWING	19.000	150.00000	2,850.00
		ACR		
0163	6090000000-E SEED FOR REPAIR SEEDING	500.000	4.00000	2,000.00
		LB		
0164	6093000000-E FERTILIZER FOR REPAIR SEEDING	1.750	800.00000	1,400.00
		TON		

Dept of Transportation

Revised:

Contract ID: C203725

Project(s): STATE FUNDED

Letting Date: 04-19-16 Call Order: 003

Bidder: 9965 - Smith-Rowe, LLC

Line No.	Item Description	Approx. Quantity and Units	Unit Price Dollars Cts	Bid Amount Dollars Ct
0165	6096000000-E SEED FOR SUPPLEMENTAL SEEDING	975.000 LB	3.00000	2,925.00
0166	6108000000-E FERTILIZER TOPDRESSING	29.250 TON	800.00000	23,400.00
0167	6111000000-E IMPERVIOUS DIKE	155.000 LF	65.00000	10,075.00
0168	6114500000-N SPECIALIZED HAND MOWING	30.000 MHR	60.00000	1,800.00
0169	6117000000-N RESPONSE FOR EROSION CONTROL	100.000 EA	50.00000	5,000.00
0170	6123000000-E REFORESTATION	8.000 ACR	750.00000	6,000.00
0171	6126000000-E STREAMBANK REFORESTATION	6.810 ACR	1,800.00000	12,258.00
0172	6132000000-N GENERIC EROSION CONTROL ITEM CONCRETE WASHOUT STRUCTURE	8.000 EA	750.00000	6,000.00
0173	6133000000-N GENERIC EROSION CONTROL ITEM DIVERSION PUMPING	LUMP	LUMP	10,000.00
0174	6133000000-N GENERIC EROSION CONTROL ITEM SITE GRADING FOR MITIGATION	LUMP	LUMP	120,000.00
0175	6133000000-N GENERIC EROSION CONTROL ITEM SURVEYING FOR MITIGATION	LUMP	LUMP	3,000.00

Dept of Transportation

Revised:

Contract ID: C203725

Project(s): STATE FUNDED

Letting Date: 04-19-16 Call Order: 003

Bidder: 9965 - Smith-Rowe, LLC

Line No.	Item Description	Approx. Quantity and Units	Unit Price Dollars Cts	Bid Amount Dollars Ct
0176	6138000000-E GENERIC EROSION CONTROL ITEM IMPERVIOUS SELECT MATERIAL	80.000 CY	20.00000	1,600.00
0177	7060000000-E SIGNAL CABLE	3,450.000 LF	2.20000	7,590.00
0178	7120000000-E VEHICLE SIGNAL HEAD (12", 3 SECTION)	20.000 EA	615.00000	12,300.00
0179	7132000000-E VEHICLE SIGNAL HEAD (12", 4 SECTION)	5.000 EA	810.00000	4,050.00
0180	7144000000-E VEHICLE SIGNAL HEAD (12", 5 SECTION)	1.000 EA	1,140.00000	1,140.00
0181	7264000000-E MESSENGER CABLE (3/8")	1,100.000 LF	3.50000	3,850.00
0182	7300000000-E UNPAVED TRENCHING (*****)(1, 2")	1,150.000 LF	6.00000	6,900.00
0183	7324000000-N JUNCTION BOX (STANDARD SIZE)	15.000 EA	275.00000	4,125.00
0184	7360000000-N WOOD POLE	2.000 EA	900.00000	1,800.00
0185	7372000000-N GUY ASSEMBLY	2.000 EA	270.00000	540.00
0186	7420000000-E 2" RISER WITH WEATHERHEAD	2.000 EA	415.00000	830.00

Contract ID: C203725

Project(s): STATE FUNDED

Letting Date: 04-19-16 Call Order: 003

Bidder: 9965 - Smith-Rowe, LLC

Line No.	Item Description	Approx. Quantity and Units	Unit Price Dollars Cts	Bid Amount Dollars Ct
0187	7444000000-E INDUCTIVE LOOP SAWCUT	2,750.000	6.00000	16,500.00
		LF		
0188	7456000000-E LEAD-IN CABLE (*****)	5,850.000	1.10000	6,435.00
	(14-2)	LF		
0189	7576000000-N METAL STRAIN SIGNAL POLE	8.000	6,900.00000	55,200.00
		EA		
0190	7613000000-N SOIL TEST	8.000	790.00000	6,320.00
		EA		
0191	7614100000-E DRILLED PIER FOUNDATION	48.000	775.00000	37,200.00
		CY		
0192	7636000000-N SIGN FOR SIGNALS	2.000	350.00000	700.00
		EA		
0193	7684000000-N SIGNAL CABINET FOUNDATION	2.000	970.00000	1,940.00
		EA		
0194	7756000000-N CONTROLLER WITH CABINET (TYPE 2070L, BASE MOUNTED)	2.000	11,900.00000	23,800.00
		EA		
0195	7780000000-N DETECTOR CARD (TYPE 2070L)	14.000	145.00000	2,030.00
		EA		
Section 0001 Total				8,180,019.95
Section 0004 STRUCTURE ITEMS				
Alt Group				
0196	8035000000-N REMOVAL OF EXISTING STRUCTURE AT STATION ***** (17+34.88 -Y-)	LUMP	LUMP	161,854.32

Contract ID: C203725

Project(s): STATE FUNDED

Letting Date: 04-19-16 Call Order: 003

Bidder: 9965 - Smith-Rowe, LLC

Line No.	Item Description	Approx. Quantity and Units	Unit Price Dollars Cts	Bid Amount Dollars Ct
0197	8091000000-N FOUNDATION EXCAVATION FOR BENT** AT STATION ***** (1, 17+34.88 -Y-)	LUMP	LUMP	13,800.00
0198	8091000000-N FOUNDATION EXCAVATION FOR BENT** AT STATION ***** (2, 17+34.88 -Y-)	LUMP	LUMP	16,200.00
0199	8096000000-E PILE EXCAVATION IN SOIL	276.000 LF	173.21000	47,805.96
0200	8097000000-E PILE EXCAVATION NOT IN SOIL	44.000 LF	173.21000	7,621.24
0201	8105540000-E 3'-6" DIA DRILLED PIERS IN SOIL	226.000 LF	225.18000	50,890.68
0202	8105640000-E 3'-6" DIA DRILLED PIERS NOT IN SOIL	67.000 LF	2,310.82000	154,824.94
0203	8111400000-E PERMANENT STEEL CASING FOR 3'-6" DIA DRILLED PIER	45.800 LF	192.40000	8,811.92
0204	8113000000-N SID INSPECTIONS	10.000 EA	625.00000	6,250.00
0205	8114000000-N SPT TESTING	10.000 EA	600.00000	6,000.00
0206	8115000000-N CSL TESTING	5.000 EA	2,375.00000	11,875.00
0207	8121000000-N UNCLASSIFIED STRUCTURE EXCAVATION AT STATION ***** (17+34.88 -Y-)	LUMP	LUMP	23,650.00

Dept of Transportation

Revised:

Contract ID: C203725

Project(s): STATE FUNDED

Letting Date: 04-19-16 Call Order: 003

Bidder: 9965 - Smith-Rowe, LLC

Line No.	Item Description	Approx. Quantity and Units	Unit Price Dollars Cts	Bid Amount Dollars Ct
0208	8147000000-E REINFORCED CONCRETE DECK SLAB	30,502.000 SF	27.48000	838,194.96
0209	8161000000-E GROOVING BRIDGE FLOORS	28,448.000 SF	0.62000	17,637.76
0210	8182000000-E CLASS A CONCRETE (BRIDGE)	608.300 CY	591.37000	359,730.37
0211	8210000000-N BRIDGE APPROACH SLABS, STATION***** (17+34.88 -Y-)	LUMP	LUMP	66,050.00
0212	8210000000-N BRIDGE APPROACH SLABS, STATION***** (90+25.00 -L-)	LUMP	LUMP	32,535.00
0213	8217000000-E REINFORCING STEEL (BRIDGE)	167,527.000 LB	0.90000	150,774.30
0214	8238000000-E SPIRAL COLUMN REINFORCING STEEL (BRIDGE)	14,580.000 LB	2.00000	29,160.00
0215	8265000000-E 54" PRESTRESSED CONCRETE GIRDERS	3,471.930 LF	225.02000	781,253.69
0216	8364000000-E HP12X53 STEEL PILES	4,660.000 LF	39.74000	185,188.40
0217	8391000000-N STEEL PILE POINTS	32.000 EA	195.00000	6,240.00
0218	8475000000-E TWO BAR METAL RAIL	1,357.000 LF	95.25000	129,254.25

Dept of Transportation

Revised:

Contract ID: C203725

Project(s): STATE FUNDED

Letting Date: 04-19-16 Call Order: 003

Bidder: 9965 - Smith-Rowe, LLC

Line No.	Item Description	Approx. Quantity and Units	Unit Price Dollars Cts	Bid Amount Dollars Ct
0219	8517000000-E 1'-**"X ***** CONCRETE PARA- PET (1'-2" X 2'-6")	1,387.000 LF	75.99000	105,398.13
0220	8524000000-E **" CHAIN LINK FENCE (72")	406.700 LF	133.06000	54,115.50
0221	8531000000-E 4" SLOPE PROTECTION	1,131.000 SY	72.31000	81,782.61
0222	8608000000-E RIP RAP CLASS II (2'-0" THICK)	1,517.000 TON	45.24000	68,629.08
0223	8622000000-E GEOTEXTILE FOR DRAINAGE	1,685.000 SY	2.25000	3,791.25
0224	8657000000-N ELASTOMERIC BEARINGS	LUMP	LUMP	15,000.00
0225	8692000000-N FOAM JOINT SEALS	LUMP	LUMP	21,925.00
0226	8706000000-N EXPANSION JOINT SEALS	LUMP	LUMP	55,875.00
0227	8860000000-N GENERIC STRUCTURE ITEM ASBESTOS ASSESSMENT	LUMP	LUMP	1,500.00
	Section 0004 Total			3,513,619.36
	Bid Total			11,693,639.31

NON-COLLUSION AND DEBARMENT CERTIFICATION

The bidder certifies that neither he, nor any official, agent or employee of the bidder has entered into any agreement, participated in any collusion, or otherwise taken any action which is in restraint of free competitive bidding in connection with this bid, and that the bidder intends to do the work with its own bonafide employees or subcontractors and is not bidding for the benefit of another contractor. In addition, submitting this electronic bid constitutes the bidder's certification of Status under penalty of perjury under the laws of the United States and in accordance with the Debarment Certification on file with the Department.

By submitting this bid, the bidder certifies to the best of his knowledge and belief that he and his principals:

- a. Are not presently debarred, suspended, proposed for debarment, declared ineligible, or voluntarily excluded from covered transactions by any Federal department or agency;
- b. Have not within a three-year period preceding this proposal been convicted of or had a civil judgment rendered against them for commission of fraud or a criminal offense in connection with obtaining, attempting to obtain, or performing a public (Federal, State or local) transaction or contract under a public transaction; violation of Federal or State antitrust statutes or commission of embezzlement, theft, forgery, bribery, falsification or destruction of records; making false statements; or receiving stolen property;
- c. Are not presently indicted for or otherwise criminally or civilly charged by a governmental entity (Federal, State or local) with commission of any of the offenses enumerated in paragraph b. of this certification; and
- d. Have not within a three-year period preceding this proposal had one or more public transactions (Federal, State or local) terminated for cause or default.

Where the prospective bidder is unable to certify to any of the statements in this certification, the bidder shall submit an explanation in the blanks provided herein. The explanation will not necessarily result in denial of participation in a contract.

Explanation:
NOT ANSWERED
NOT ANSWERED
NOT ANSWERED
NOT ANSWERED

If the prequalified bidder's status changes, he shall immediately submit a new fully executed non-collusion affidavit and debarment certification with an explanation of the change to the Contract Office prior to submitting the bid.

Failure to furnish a certification or an explanation will be grounds for rejection of a bid

AWARD LIMITS ON MULTIPLE PROJECTS

By answering YES to this statement, the bidder acknowledges that they are using the award limits on multiple projects. No

A bidder who desires to bid on more than one project on which bids are to be opened on the same date, and who also desires to avoid receiving an award of more projects than he is equipped to handle, may bid on any number of projects but may limit the total amount of work awarded to him on selected projects by completing the AWARD LIMITS ON MULTIPLE PROJECTS.

The Award Limits on Multiple Projects must be filled in on each project bid for which the Bidder desires protection.

It is the desire of the Bidder to be awarded contracts, the value of which will not exceed a total of NOT ANSWERED for those projects indicated herein, for which bids will be opened on (MM/DD/YY)

The Award Limits shall apply to the following projects:

Contract Number	County
NOT ANSWERED	
NOT ANSWERED	
NOT ANSWERED	
NOT ANSWERED	
NOT ANSWERED	
NOT ANSWERED	

It is agreed that if I am (we are) the low Bidder(s) on indicated projects, the total value of which is more than the above stipulated award limits, the Board of Transportation will award me (us) projects from among those indicated that have a total value not to exceed the award limit and will result in the lowest total bids to the Department of Transportation.

PROPOSAL: C203725
LETTING: L160419 CALL: 003
VENDOR: 9965 Smith-Rowe, LLC

LINE NO.	ITEM NO.	ITEM DESC.	UNIT TYPE	SUBCONTRACTOR QUANTITY	SUBCONTRACTOR UNIT PRICE	EXTENDED AMOUNT
----------	----------	------------	-----------	------------------------	--------------------------	-----------------

MBE SUBCONTRACTOR: 9602 CAROLINA TRANSPORT OF GREENSBORO INC
Will Use Quote: Yes

0049	1489000000-E	ASP CONC BAS	TON	1.000	15000.00000	15000.00
0050	1498000000-E	ASP CONC INT	TON	1.000	60000.00000	60000.00
0051	1519000000-E	ASP CONC SUR	TON	1.000	75000.00000	75000.00

MBE COMMITMENT TOTAL FOR SUBCONTRACTOR: 150,000.00 **Committed**

MBE SUBCONTRACTOR: 12289 SMITH JAMISON DBA SMITH JAMISON
Will Use Quote: Yes

0001	0000100000-N	MOBILIZATION	LS	1.000	2000.00000	2000.00
0071	2451000000-N	CONC TRANS	S EA	1.000	1032.00000	1032.00
0072	2549000000-E	2'-6" CONC	C LF	900.000	13.75000	12375.00
0073	2556000000-E	SHOULDER BER	LF	1630.000	17.25000	28117.50
0074	2605000000-N	CONCRETE CUR	EA	10.000	1225.00000	12250.00
0075	2612000000-E	6" CONCRETE	SY	20.000	36.50000	730.00
0076	2619000000-E	4" CONCRETE	SY	11.000	36.50000	401.50
0077	2647000000-E	5" MONO CONC	SY	260.000	42.50000	11050.00

MBE COMMITMENT TOTAL FOR SUBCONTRACTOR: 67,956.00 **Committed**

TOTAL MBE COMMITMENT FOR VENDOR:	Entered:	1.86% or	217956.00
	Required:	4.00% or	467745.57
			<GOAL NOT MET>

PROPOSAL: C203725
LETTING: L160419 CALL: 003
VENDOR: 9965 Smith-Rowe, LLC

LINE ITEM ITEM UNIT SUBCONTRACTOR SUBCONTRACTOR EXTENDED
NO. NO. DESC. TYPE QUANTITY UNIT PRICE AMOUNT

WBE SUBCONTRACTOR: 12802 NICKELSTON INDUSTRIES, INC.
Will Use Quote: Yes

0078	3030000000-E	STL BM GUARD LF	4987.500	13.50000	67331.25
0079	3045000000-E	SBGR SHOP CU LF	162.500	14.50000	2356.25
0080	3150000000-N	ADDIT GUARDR EA	10.000	25.00000	250.00
0081	3215000000-N	GR ANCHOR TY EA	8.000	1550.00000	12400.00
0082	3270000000-N	GR ANCHOR TY EA	10.000	1700.00000	17000.00

WBE COMMITMENT TOTAL FOR SUBCONTRACTOR: 99,337.50 Committed

WBE SUBCONTRACTOR: 11402 FLORENCE CONCRETE PRODUCTS, INC.
Will Use Quote: Yes

0215	8265000000-E	54" PRESTR C LF	3471.930	132.61000	460412.64
------	--------------	-----------------	----------	-----------	-----------

WBE COMMITMENT TOTAL FOR SUBCONTRACTOR: 460,412.64 Committed

WBE SUBCONTRACTOR: 3230 HIATT & MASON ENTERPRISES INC
Will Use Quote: Yes

0208	8147000000-E	REINF CONCRE SF	30502.000	2.05000	62529.10
------	--------------	-----------------	-----------	---------	----------

WBE COMMITMENT TOTAL FOR SUBCONTRACTOR: 62,529.10 Committed

WBE SUBCONTRACTOR: 4761 TRAFFIC CONTROL SAFETY SERVICES, INC.
Will Use Quote: Yes

0089	4072000000-E	SUPPORT, 3-L LF	565.000	5.50000	3107.50
0090	4096000000-N	SIGN ERECTIO EA	5.000	95.00000	475.00
0091	4102000000-N	SIGN ERECTIO EA	20.000	55.00000	1100.00
0092	4108000000-N	SIGN ERECTIO EA	3.000	95.00000	285.00
0093	4155000000-N	DISPOSE SIGN EA	25.000	1.00000	25.00
0094	4400000000-E	WORK ZONE SI SF	482.000	4.50000	2169.00
0096	4410000000-E	WORK ZONE SI SF	171.000	6.00000	1026.00
0101	4445000000-E	BARRICADES (LF	152.000	18.00000	2736.00

WBE COMMITMENT TOTAL FOR SUBCONTRACTOR: 10,923.50 Committed

WBE SUBCONTRACTOR: 3418 NORTH STATE ENVIRONMENTAL, INC
Will Use Quote: Yes

0174	6133000000-N	GENERIC EROS LS	1.000	78441.43000	78441.43
------	--------------	-----------------	-------	-------------	----------

WBE COMMITMENT TOTAL FOR SUBCONTRACTOR: 78,441.43 Committed

LINE ITEM ITEM UNIT SUBCONTRACTOR SUBCONTRACTOR EXTENDED
NO. NO. DESC. TYPE QUANTITY UNIT PRICE AMOUNT

WBE SUBCONTRACTOR: 4434 LONG BROTHERS OF SUMMERFIELD, INC.
Will Use Quote: Yes

0041	1121000000-E	AGGREGATE BA TON	10000.000	10.50000	105000.00

		WBE COMMITMENT TOTAL FOR SUBCONTRACTOR:			105,000.00 Committed

TOTAL WBE COMMITMENT FOR VENDOR:	Entered:	6.98% or	816644.17
	Required:	6.00% or	701618.36
			<GOAL MET>

THIS PROPOSAL CONTAINS THE FOLLOWING ERRORS/WARNINGS (IF ANY)

DBE Warning : MBE Warning: MBE Commitment Goal not met

This Bid contains 0 amendment files

Electronic Bid Submission

By submitting this bid electronically, I hereby acknowledge that all requirements included in the hard copy proposal, addendum, amendments, plans, standard specifications, supplemental specifications and special provisions are part of the bid and contract. Further, I acknowledge that I have read, understand, accept, acknowledge and agree to comply with all statements in this electronic bid.

I Hereby certify that I have the authority to submit this bid.

Signature

Agency

Date

Contract Item Sheets For C203725

Line #	ItemNumber	Sec #	Description	Quantity Unit	Unit Bid Price	Amount Bid
ROADWAY ITEMS						
0001	0000100000-N	800	MOBILIZATION	Lump Sum LS	584,500.00	584,500.00
0002	0000400000-N	801	CONSTRUCTION SURVEYING	Lump Sum LS	66,650.00	66,650.00
0003	0001000000-E	200	CLEARING & GRUBBING .. ACRE(S)	Lump Sum LS	805,300.00	805,300.00
0004	0008000000-E	200	SUPPLEMENTARY CLEARING & GRUB- BING	2 ACR	1.00	2.00
0005	0022000000-E	225	UNCLASSIFIED EXCAVATION	71,000 CY	4.32	306,720.00
0006	0029000000-N	SP	REINFORCED BRIDGE APPROACH FILL, STATION ***** (17+35 -Y-)	Lump Sum LS	79,400.00	79,400.00
0007	0029000000-N	SP	REINFORCED BRIDGE APPROACH FILL, STATION ***** (90+25 -L-)	Lump Sum LS	34,725.00	34,725.00
0008	0036000000-E	225	UNDERCUT EXCAVATION	1,000 CY	12.50	12,500.00
0009	0106000000-E	230	BORROW EXCAVATION	140,000 CY	5.60	784,000.00
0010	0134000000-E	240	DRAINAGE DITCH EXCAVATION	4,440 CY	5.35	23,754.00
0011	0141000000-E	240	BERM DITCH CONSTRUCTION	240 LF	4.50	1,080.00
0012	0156000000-E	250	REMOVAL OF EXISTING ASPHALT PAVEMENT	1,090 SY	5.65	6,158.50
0013	0192000000-N	260	PROOF ROLLING	20 HR	250.00	5,000.00
0014	0195000000-E	265	SELECT GRANULAR MATERIAL	3,500 CY	15.00	52,500.00
0015	0196000000-E	270	GEOTEXTILE FOR SOIL STABILIZA- TION	5,600 SY	2.05	11,480.00
0016	0318000000-E	300	FOUNDATION CONDITIONING MATE- RIAL, MINOR STRUCTURES	468 TON	34.00	15,912.00
0017	0320000000-E	300	FOUNDATION CONDITIONING GEO- TEXTILE	1,762 SY	3.00	5,286.00
0018	0335200000-E	305	15" DRAINAGE PIPE	1,020 LF	36.50	37,230.00
0019	0335300000-E	305	18" DRAINAGE PIPE	88 LF	43.75	3,850.00

Line #	ItemNumber	Sec #	Description	Quantity Unit	Unit Bid Price	Amount Bid
0020	0335400000-E	305	24" DRAINAGE PIPE	676 LF	54.75	37,011.00
0021	0335500000-E	305	30" DRAINAGE PIPE	476 LF	72.00	34,272.00
0022	0335800000-E	305	48" DRAINAGE PIPE	416 LF	103.00	42,848.00
0023	0344000000-E	310	18" SIDE DRAIN PIPE	88 LF	43.75	3,850.00
0024	0448200000-E	310	15" RC PIPE CULVERTS, CLASS IV	144 LF	46.00	6,624.00
0025	0582000000-E	310	15" CS PIPE CULVERTS, 0.064" THICK	444 LF	62.50	27,750.00
0026	0594000000-E	310	24" CS PIPE CULVERTS, 0.064" THICK	40 LF	57.75	2,310.00
0027	0636000000-E	310	***" CS PIPE ELBOWS, ***** THICK (15", 0.064")	22 EA	150.00	3,300.00
0028	0636000000-E	310	***" CS PIPE ELBOWS, ***** THICK (24", 0.064")	2 EA	200.00	400.00
0029	0974000000-E	SP	***" WELDED STEEL PIPE, ***** THICK, GRADE B, (UNDER RR) (36", 0.500")	130 LF	465.00	60,450.00
0030	0974000000-E	SP	***" WELDED STEEL PIPE, ***** THICK, GRADE B, (UNDER RR) (48", 0.625")	120 LF	650.00	78,000.00
0031	0986000000-E	SP	GENERIC PIPE ITEM 95" X 67" CORRUGATED ALUMINUM ALLOY PIPE ARCH, WITH HEADWALLS	36 LF	2,550.00	91,800.00
0032	0995000000-E	340	PIPE REMOVAL	548 LF	15.50	8,494.00
0033	1011000000-N	500	FINE GRADING	Lump Sum LS	448,411.00	448,411.00
0034	1044000000-E	501	LIME TREATED SOIL (SLURRY METHOD)	27,120 SY	3.35	90,852.00
0035	1066000000-E	501	LIME FOR LIME TREATED SOIL	280 TON	217.00	60,760.00
0036	1077000000-E	SP	#57 STONE	241 TON	35.00	8,435.00

Line #	ItemNumber	Sec #	Description	Quantity Unit	Unit Bid Price	Amount Bid
0037	1099500000-E	505	SHALLOW UNDERCUT	850 CY	10.41	8,848.50
0038	1099700000-E	505	CLASS IV SUBGRADE STABILIZATION	1,600 TON	27.25	43,600.00
0039	1110000000-E	510	STABILIZER AGGREGATE	500 TON	29.90	14,950.00
0040	1115000000-E	SP	GEOTEXTILE FOR PAVEMENT STABILIZATION	13,500 SY	2.25	30,375.00
0041	1121000000-E	520	AGGREGATE BASE COURSE	20,500 TON	23.50	481,750.00
0042	1176000000-E	542	SOIL CEMENT BASE	18,080 SY	2.45	44,296.00
0043	1187000000-E	542	PORTLAND CEMENT FOR SOIL CEMENT BASE	498 TON	169.00	84,162.00
0044	1209000000-E	543	ASPHALT CURING SEAL	6,780 GAL	5.00	33,900.00
0045	1220000000-E	545	INCIDENTAL STONE BASE	300 TON	50.00	15,000.00
0046	1275000000-E	600	PRIME COAT	70 GAL	3.25	227.50
0047	1308000000-E	607	MILLING ASPHALT PAVEMENT, **** TO ***** (0" TO 1-1/2")	200 SY	22.00	4,400.00
0048	1330000000-E	607	INCIDENTAL MILLING	300 SY	22.00	6,600.00
0049	1489000000-E	610	ASPHALT CONC BASE COURSE, TYPE B25.0B	1,740 TON	61.45	106,923.00
0050	1498000000-E	610	ASPHALT CONC INTERMEDIATE COURSE, TYPE I19.0B	7,400 TON	46.16	341,584.00
0051	1519000000-E	610	ASPHALT CONC SURFACE COURSE, TYPE S9.5B	8,760 TON	48.05	420,918.00
0052	1575000000-E	620	ASPHALT BINDER FOR PLANT MIX	960 TON	300.00	288,000.00
0053	1693000000-E	654	ASPHALT PLANT MIX, PAVEMENT REPAIR	10 TON	400.00	4,000.00
0054	2000000000-N	806	RIGHT OF WAY MARKERS	61 EA	158.95	9,695.95
0055	2022000000-E	815	SUBDRAIN EXCAVATION	1,008 CY	10.00	10,080.00

Line #	ItemNumber	Sec #	Description	Quantity Unit	Unit Bid Price	Amount Bid
0056	2033000000-E	815	SUBDRAIN FINE AGGREGATE	504 CY	35.00	17,640.00
0057	2044000000-E	815	6" PERFORATED SUBDRAIN PIPE	3,000 LF	5.00	15,000.00
0058	2070000000-N	815	SUBDRAIN PIPE OUTLET	6 EA	100.00	600.00
0059	2077000000-E	815	6" OUTLET PIPE	36 LF	15.00	540.00
0060	2143000000-E	818	BLOTTING SAND	10 TON	35.00	350.00
0061	2209000000-E	838	ENDWALLS	35.6 CY	1,050.00	37,380.00
0062	2253000000-E	840	PIPE COLLARS	1.013 CY	2,171.69	2,199.92
0063	2264000000-E	840	PIPE PLUGS	0.09 CY	3,558.09	320.23
0064	2286000000-N	840	MASONRY DRAINAGE STRUCTURES	29 EA	1,195.00	34,655.00
0065	2308000000-E	840	MASONRY DRAINAGE STRUCTURES	23.32 LF	221.50	5,165.38
0066	2354000000-N	840	FRAME WITH GRATE, STD 840.22	1 EA	930.15	930.15
0067	2364000000-N	840	FRAME WITH TWO GRATES, STD 840.16	2 EA	1,150.00	2,300.00
0068	2365000000-N	840	FRAME WITH TWO GRATES, STD 840.22	1 EA	1,050.00	1,050.00
0069	2367000000-N	840	FRAME WITH TWO GRATES, STD 840.29	20 EA	500.00	10,000.00
0070	2374000000-N	840	FRAME WITH GRATE & HOOD, STD 840.03, TYPE ** (F)	6 EA	600.00	3,600.00
0071	2451000000-N	852	CONCRETE TRANSITIONAL SECTION FOR DROP INLET	1 EA	1,032.00	1,032.00
0072	2549000000-E	846	2'-6" CONCRETE CURB & GUTTER	900 LF	13.75	12,375.00
0073	2556000000-E	846	SHOULDER BERM GUTTER	1,630 LF	17.25	28,117.50
0074	2605000000-N	848	CONCRETE CURB RAMP	10 EA	1,225.00	12,250.00

Line #	ItemNumber	Sec #	Description	Quantity Unit	Unit Bid Price	Amount Bid
0075	2612000000-E	848	6" CONCRETE DRIVEWAY	20 SY	90.00	1,800.00
0076	2619000000-E	850	4" CONCRETE PAVED DITCH	11 SY	36.50	401.50
0077	2647000000-E	852	5" MONOLITHIC CONCRETE ISLANDS (SURFACE MOUNTED)	260 SY	42.50	11,050.00
0078	3030000000-E	862	STEEL BM GUARDRAIL	4,987.5 LF	13.50	67,331.25
0079	3045000000-E	862	STEEL BM GUARDRAIL, SHOP CURVED	162.5 LF	14.50	2,356.25
0080	3150000000-N	862	ADDITIONAL GUARDRAIL POSTS	10 EA	1.00	10.00
0081	3215000000-N	862	GUARDRAIL ANCHOR UNITS, TYPE III	8 EA	1,550.00	12,400.00
0082	3270000000-N	SP	GUARDRAIL ANCHOR UNITS, TYPE 350	10 EA	1,700.00	17,000.00
0083	3628000000-E	876	RIP RAP, CLASS I	365 TON	43.35	15,822.75
0084	3642000000-E	876	RIP RAP, CLASS A	25 TON	40.50	1,012.50
0085	3649000000-E	876	RIP RAP, CLASS B	1,050 TON	36.00	37,800.00
0086	3651000000-E	SP	BOULDERS	732 TON	65.00	47,580.00
0087	3656000000-E	876	GEOTEXTILE FOR DRAINAGE	8,980 SY	2.17	19,486.60
0088	3659000000-N	SP	PREFORMED SCOUR HOLES WITH LEVEL SPREADER APRON	8 EA	1,265.00	10,120.00
0089	4072000000-E	903	SUPPORTS, 3-LB STEEL U-CHANNEL	565 LF	5.50	3,107.50
0090	4096000000-N	904	SIGN ERECTION, TYPE D	5 EA	95.00	475.00
0091	4102000000-N	904	SIGN ERECTION, TYPE E	20 EA	55.00	1,100.00
0092	4108000000-N	904	SIGN ERECTION, TYPE F	3 EA	95.00	285.00
0093	4155000000-N	907	DISPOSAL OF SIGN SYSTEM, U-CHANNEL	25 EA	1.00	25.00

Line #	ItemNumber	Sec #	Description	Quantity Unit	Unit Bid Price	Amount Bid
0094	4400000000-E	1110	WORK ZONE SIGNS (STATIONARY)	482 SF	4.50	2,169.00
0095	4405000000-E	1110	WORK ZONE SIGNS (PORTABLE)	394 SF	13.35	5,259.90
0096	4410000000-E	1110	WORK ZONE SIGNS (BARRICADE MOUNTED)	171 SF	6.00	1,026.00
0097	4415000000-N	1115	FLASHING ARROW BOARD	2 EA	2,050.00	4,100.00
0098	4420000000-N	1120	PORTABLE CHANGEABLE MESSAGE SIGN	4 EA	4,775.00	19,100.00
0099	4430000000-N	1130	DRUMS	200 EA	63.75	12,750.00
0100	4435000000-N	1135	CONES	200 EA	32.35	6,470.00
0101	4445000000-E	1145	BARRICADES (TYPE III)	152 LF	18.00	2,736.00
0102	4450000000-N	1150	FLAGGER	720 HR	26.00	18,720.00
0103	4480000000-N	1165	TMA	2 EA	1,000.00	2,000.00
0104	4510000000-N	SP	LAW ENFORCEMENT	80 HR	47.25	3,780.00
0105	4516000000-N	1180	SKINNY DRUM	200 EA	15.00	3,000.00
0106	4650000000-N	1251	TEMPORARY RAISED PAVEMENT MARKERS	311 EA	12.00	3,732.00
0107	4685000000-E	1205	THERMOPLASTIC PAVEMENT MARKING LINES (4", 90 MILS)	25,540 LF	0.64	16,345.60
0108	4686000000-E	1205	THERMOPLASTIC PAVEMENT MARKING LINES (4", 120 MILS)	31,616 LF	0.74	23,395.84
0109	4700000000-E	1205	THERMOPLASTIC PAVEMENT MARKING LINES (12", 90 MILS)	120 LF	4.50	540.00
0110	4710000000-E	1205	THERMOPLASTIC PAVEMENT MARKING LINES (24", 120 MILS)	270 LF	12.25	3,307.50
0111	4725000000-E	1205	THERMOPLASTIC PAVEMENT MARKING SYMBOL (90 MILS)	40 EA	100.00	4,000.00

Line #	ItemNumber	Sec #	Description	Quantity Unit	Unit Bid Price	Amount Bid
0112	4770000000-E	1205	COLD APPLIED PLASTIC PAVEMENT MARKING LINES, TYPE ** (4") (II)	1,405 LF	2.65	3,723.25
0113	4805000000-N	1205	COLD APPLIED PLASTIC PAVEMENT MARKING SYMBOL, TYPE ** (II)	4 EA	1,100.00	4,400.00
0114	4810000000-E	1205	PAINT PAVEMENT MARKING LINES (4")	16,890 LF	0.32	5,404.80
0115	4825000000-E	1205	PAINT PAVEMENT MARKING LINES (12")	111 LF	3.00	333.00
0116	4835000000-E	1205	PAINT PAVEMENT MARKING LINES (24")	100 LF	4.00	400.00
0117	4845000000-N	1205	PAINT PAVEMENT MARKING SYMBOL	23 EA	75.00	1,725.00
0118	4900000000-N	1251	PERMANENT RAISED PAVEMENT MARKERS	336 EA	12.00	4,032.00
0119	5326200000-E	1510	12" WATER LINE	40 LF	277.15	11,086.00
0120	5326600000-E	1510	16" WATER LINE	789 LF	131.07	103,414.23
0121	5558000000-E	1515	12" VALVE	1 EA	2,847.55	2,847.55
0122	5558600000-E	1515	16" VALVE	2 EA	7,877.45	15,754.90
0123	5572600000-E	1515	16" TAPPING VALVE	1 EA	27,165.91	27,165.91
0124	5643000000-E	1515	*** WATER METER (5/8")	3 EA	1,654.16	4,962.48
0125	5648000000-N	1515	RELOCATE WATER METER	3 EA	1,654.16	4,962.48
0126	5649000000-N	1515	RECONNECT WATER METER	3 EA	1,654.16	4,962.48
0127	5691900000-E	1520	24" SANITARY GRAVITY SEWER	1,135 LF	197.17	223,787.95
0128	5776000000-E	1525	5' DIA UTILITY MANHOLE	4 EA	5,544.39	22,177.56
0129	5782000000-E	1525	UTILITY MANHOLE WALL, 5' DIA	11.8 LF	131.80	1,555.24
0130	5804000000-E	1530	ABANDON 12" UTILITY PIPE	125 LF	8.48	1,060.00

Line #	ItemNumber	Sec #	Description	Quantity Unit	Unit Bid Price	Amount Bid
0131	5810000000-E	1530	ABANDON 16" UTILITY PIPE	528 LF	12.24	6,462.72
0132	5813000000-E	1530	ABANDON 24" UTILITY PIPE	1,052 LF	24.09	25,342.68
0133	5816000000-N	1530	ABANDON UTILITY MANHOLE	3 EA	1,299.05	3,897.15
0134	5836200000-E	1540	30" ENCASEMENT PIPE	60 LF	495.51	29,730.60
0135	5836400000-E	1540	36" ENCASEMENT PIPE	70 LF	508.88	35,621.60
0136	5872300000-E	1550	TRENCHLESS INSTALLATION OF 30" IN SOIL	30 LF	950.68	28,520.40
0137	5872310000-E	1550	TRENCHLESS INSTALLATION OF 30" NOT IN SOIL	30 LF	1,192.43	35,772.90
0138	5872400000-E	1550	TRENCHLESS INSTALLATION OF 36" IN SOIL	35 LF	283.10	9,908.50
0139	5872410000-E	1550	TRENCHLESS INSTALLATION OF 36" NOT IN SOIL	35 LF	673.20	23,562.00
0140	6000000000-E	1605	TEMPORARY SILT FENCE	37,400 LF	1.55	57,970.00
0141	6006000000-E	1610	STONE FOR EROSION CONTROL, CLASS A	560 TON	50.00	28,000.00
0142	6009000000-E	1610	STONE FOR EROSION CONTROL, CLASS B	5,785 TON	25.00	144,625.00
0143	6012000000-E	1610	SEDIMENT CONTROL STONE	8,705 TON	22.75	198,038.75
0144	6015000000-E	1615	TEMPORARY MULCHING	46 ACR	1,500.00	69,000.00
0145	6018000000-E	1620	SEED FOR TEMPORARY SEEDING	2,650 LB	0.25	662.50
0146	6021000000-E	1620	FERTILIZER FOR TEMPORARY SEEDING	14.5 TON	100.00	1,450.00
0147	6024000000-E	1622	TEMPORARY SLOPE DRAINS	3,600 LF	10.00	36,000.00
0148	6029000000-E	SP	SAFETY FENCE	4,600 LF	2.50	11,500.00
0149	6030000000-E	1630	SILT EXCAVATION	19,300 CY	2.00	38,600.00

Line #	ItemNumber	Sec #	Description	Quantity Unit	Unit Bid Price	Amount Bid
0150	6036000000-E	1631	MATTING FOR EROSION CONTROL	50,000 SY	1.24	62,000.00
0151	6037000000-E	SP	COIR FIBER MAT	230 SY	15.00	3,450.00
0152	6038000000-E	SP	PERMANENT SOIL REINFORCEMENT MAT	445 SY	13.50	6,007.50
0153	6042000000-E	1632	1/4" HARDWARE CLOTH	3,700 LF	3.00	11,100.00
0154	6046000000-E	1636	TEMPORARY PIPE FOR STREAM CROSSING	75 LF	50.00	3,750.00
0155	6070000000-N	1639	SPECIAL STILLING BASINS	37 EA	90.00	3,330.00
0156	6071012000-E	SP	COIR FIBER WATTLE	2,900 LF	6.50	18,850.00
0157	6071020000-E	SP	POLYACRYLAMIDE (PAM)	2,000 LB	1.00	2,000.00
0158	6071030000-E	1640	COIR FIBER BAFFLE	4,000 LF	4.50	18,000.00
0159	6071050000-E	SP	*** SKIMMER (1-1/2")	13 EA	940.00	12,220.00
0160	6071050000-E	SP	*** SKIMMER (2")	6 EA	1,085.00	6,510.00
0161	6084000000-E	1660	SEEDING & MULCHING	28 ACR	1,600.00	44,800.00
0162	6087000000-E	1660	MOWING	19 ACR	150.00	2,850.00
0163	6090000000-E	1661	SEED FOR REPAIR SEEDING	500 LB	4.00	2,000.00
0164	6093000000-E	1661	FERTILIZER FOR REPAIR SEEDING	1.75 TON	800.00	1,400.00
0165	6096000000-E	1662	SEED FOR SUPPLEMENTAL SEEDING	975 LB	3.00	2,925.00
0166	6108000000-E	1665	FERTILIZER TOPDRESSING	29.25 TON	800.00	23,400.00
0167	6111000000-E	SP	IMPERVIOUS DIKE	155 LF	65.00	10,075.00
0168	6114500000-N	1667	SPECIALIZED HAND MOWING	30 MHR	60.00	1,800.00
0169	6117000000-N	SP	RESPONSE FOR EROSION CONTROL	100 EA	50.00	5,000.00

Line #	ItemNumber	Sec #	Description	Quantity Unit	Unit Bid Price	Amount Bid
0170	6123000000-E	1670	REFORESTATION	8 ACR	750.00	6,000.00
0171	6126000000-E	SP	STREAMBANK REFORESTATION	6.81 ACR	1,800.00	12,258.00
0172	6132000000-N	SP	GENERIC EROSION CONTROL ITEM CONCRETE WASHOUT STRUCTURE	8 EA	750.00	6,000.00
0173	6133000000-N	SP	GENERIC EROSION CONTROL ITEM DIVERSION PUMPING	Lump Sum LS	10,000.00	10,000.00
0174	6133000000-N	SP	GENERIC EROSION CONTROL ITEM SITE GRADING FOR MITIGATION	Lump Sum LS	120,000.00	120,000.00
0175	6133000000-N	SP	GENERIC EROSION CONTROL ITEM SURVEYING FOR MITIGATION	Lump Sum LS	3,000.00	3,000.00
0176	6138000000-E	SP	GENERIC EROSION CONTROL ITEM IMPERVIOUS SELECT MATERIAL	80 CY	20.00	1,600.00
0177	7060000000-E	1705	SIGNAL CABLE	3,450 LF	2.20	7,590.00
0178	7120000000-E	1705	VEHICLE SIGNAL HEAD (12", 3 SECTION)	20 EA	615.00	12,300.00
0179	7132000000-E	1705	VEHICLE SIGNAL HEAD (12", 4 SECTION)	5 EA	810.00	4,050.00
0180	7144000000-E	1705	VEHICLE SIGNAL HEAD (12", 5 SECTION)	1 EA	1,140.00	1,140.00
0181	7264000000-E	1710	MESSENGER CABLE (3/8")	1,100 LF	3.50	3,850.00
0182	7300000000-E	1715	UNPAVED TRENCHING (***** (1, 2"))	1,150 LF	6.00	6,900.00
0183	7324000000-N	1716	JUNCTION BOX (STANDARD SIZE)	15 EA	275.00	4,125.00
0184	7360000000-N	1720	WOOD POLE	2 EA	900.00	1,800.00
0185	7372000000-N	1721	GUY ASSEMBLY	2 EA	270.00	540.00
0186	7420000000-E	1722	2" RISER WITH WEATHERHEAD	2 EA	415.00	830.00
0187	7444000000-E	1725	INDUCTIVE LOOP SAWCUT	2,750 LF	6.00	16,500.00

Contract Item Sheets For C203725

Line #	ItemNumber	Sec #	Description	Quantity Unit	Unit Bid Price	Amount Bid
0188	7456000000-E	1726	LEAD-IN CABLE (***** (14-2)	5,850 LF	1.10	6,435.00
0189	7576000000-N	SP	METAL STRAIN SIGNAL POLE	8 EA	6,900.00	55,200.00
0190	7613000000-N	SP	SOIL TEST	8 EA	790.00	6,320.00
0191	7614100000-E	SP	DRILLED PIER FOUNDATION	48 CY	775.00	37,200.00
0192	7636000000-N	1745	SIGN FOR SIGNALS	2 EA	350.00	700.00
0193	7684000000-N	1750	SIGNAL CABINET FOUNDATION	2 EA	970.00	1,940.00
0194	7756000000-N	1751	CONTROLLER WITH CABINET (TYPE 2070L, BASE MOUNTED)	2 EA	11,900.00	23,800.00
0195	7780000000-N	1751	DETECTOR CARD (TYPE 2070L)	14 EA	145.00	2,030.00

Contract Item Sheets For C203725

Line #	ItemNumber	Sec #	Description	Quantity Unit	Unit Bid Price	Amount Bid
0196	8035000000-N	402	REMOVAL OF EXISTING STRUCTURE AT STATION ***** (17+34.88 -Y-)	Lump Sum LS	161,854.32	161,854.32
0197	8091000000-N	410	FOUNDATION EXCAVATION FOR BENT ** AT STATION ***** (1, 17+34.88 -Y-)	Lump Sum LS	13,800.00	13,800.00
0198	8091000000-N	410	FOUNDATION EXCAVATION FOR BENT ** AT STATION ***** (2, 17+34.88 -Y-)	Lump Sum LS	16,200.00	16,200.00
0199	8096000000-E	450	PILE EXCAVATION IN SOIL	276 LF	173.21	47,805.96
0200	8097000000-E	450	PILE EXCAVATION NOT IN SOIL	44 LF	173.21	7,621.24
0201	8105540000-E	411	3'-6" DIA DRILLED PIERS IN SOIL	226 LF	225.18	50,890.68
0202	8105640000-E	411	3'-6" DIA DRILLED PIERS NOT IN SOIL	67 LF	2,310.82	154,824.94
0203	8111400000-E	411	PERMANENT STEEL CASING FOR 3'-6" DIA DRILLED PIER	45.8 LF	192.40	8,811.92
0204	8113000000-N	411	SID INSPECTIONS	10 EA	625.00	6,250.00
0205	8114000000-N	411	SPT TESTING	10 EA	600.00	6,000.00
0206	8115000000-N	411	CSL TESTING	5 EA	2,375.00	11,875.00
0207	8121000000-N	412	UNCLASSIFIED STRUCTURE EXCAVA- TION AT STATION ***** (17+34.88 -Y-)	Lump Sum LS	23,650.00	23,650.00
0208	8147000000-E	420	REINFORCED CONCRETE DECK SLAB	30,502 SF	27.48	838,194.96
0209	8161000000-E	420	GROOVING BRIDGE FLOORS	28,448 SF	0.62	17,637.76
0210	8182000000-E	420	CLASS A CONCRETE (BRIDGE)	608.3 CY	591.37	359,730.37
0211	8210000000-N	422	BRIDGE APPROACH SLABS, STATION ***** (17+34.88 -Y-)	Lump Sum LS	66,050.00	66,050.00
0212	8210000000-N	422	BRIDGE APPROACH SLABS, STATION ***** (90+25.00 -L-)	Lump Sum LS	32,535.00	32,535.00

Line #	ItemNumber	Sec #	Description	Quantity Unit	Unit Bid Price	Amount Bid
0213	8217000000-E	425	REINFORCING STEEL (BRIDGE)	167,527 LB	0.90	150,774.30
0214	8238000000-E	425	SPIRAL COLUMN REINFORCING STEEL (BRIDGE)	14,580 LB	2.00	29,160.00
0215	8265000000-E	430	54" PRESTRESSED CONCRETE GIRDERS	3,471.93 LF	225.02	781,253.69
0216	8364000000-E	450	HP12X53 STEEL PILES	4,660 LF	39.74	185,188.40
0217	8391000000-N	450	STEEL PILE POINTS	32 EA	195.00	6,240.00
0218	8475000000-E	460	TWO BAR METAL RAIL	1,357 LF	95.25	129,254.25
0219	8517000000-E	460	1'-***"X ***** CONCRETE PARAPET (1'-2" X 2'-6")	1,387 LF	75.99	105,398.13
0220	8524000000-E	SP	*** CHAIN LINK FENCE (72")	406.7 LF	133.06	54,115.50
0221	8531000000-E	462	4" SLOPE PROTECTION	1,131 SY	72.31	81,782.61
0222	8608000000-E	876	RIP RAP CLASS II (2'-0" THICK)	1,517 TON	45.24	68,629.08
0223	8622000000-E	876	GEOTEXTILE FOR DRAINAGE	1,685 SY	2.25	3,791.25
0224	8657000000-N	430	ELASTOMERIC BEARINGS	Lump Sum LS	15,000.00	15,000.00
0225	8692000000-N	SP	FOAM JOINT SEALS	Lump Sum LS	21,925.00	21,925.00
0226	8706000000-N	SP	EXPANSION JOINT SEALS	Lump Sum LS	55,875.00	55,875.00
0227	8860000000-N	SP	GENERIC STRUCTURE ITEM ASBESTOS ASSESSMENT	Lump Sum LS	1,500.00	1,500.00

TOTAL AMOUNT OF BID FOR ENTIRE PROJECT

\$11,693,639.31

Contract No. C203725
County Forsyth

Rev. 5-19-11

**EXECUTION OF CONTRACT
NON-COLLUSION AFFIDAVIT, DEBARMENT CERTIFICATION AND GIFT BAN CERTIFICATION
LIMITED LIABILITY COMPANY**

The Contractor being duly sworn, solemnly swears (or affirms) that neither he, nor any official, agent or employee has entered into any agreement, participated in any collusion, or otherwise taken any action which is in restraint of free competitive bidding in connection with this Contract, that the Contractor has not been convicted of violating N.C.G.S. § 133-24 within the last three years, and that the Contractor intends to do the work with its own bonafide employees or subcontractors and did not bid for the benefit of another contractor.

By submitting this Execution of Contract, Non-Collusion Affidavit and Debarment Certification, the Contractor is certifying his status under penalty of perjury under the laws of the United States in accordance with the Debarment Certification attached, provided that the Debarment Certification also includes any required statements concerning exceptions that are applicable.

N.C.G.S. § 133-32 and Executive Order 24 prohibit the offer to, or acceptance by, any State Employee of any gift from anyone with a contract with the State, or from any person seeking to do business with the State. By execution of any response in this procurement, you attest, for your entire organization and its employees or agents, that you are not aware that any such gift has been offered, accepted, or promised by any employees of your organization.

SIGNATURE OF CONTRACTOR

Smith-Rowe, LLC

Full Name of Firm

639 Old US 52 South, Mount Airy, NC 27030

Address as Prequalified

William F. Fulp
Signature of Witness

David L. Rowe
Signature of Member/Manager/Authorized Agent
Select appropriate title

William F. Fulp

Print or type Signer's name

David L. Rowe

Print or type Signer's Name

AFFIDAVIT MUST BE NOTARIZED

Subscribed and sworn to before me this the

3 day of May 2016.

Elizabeth Stanley Calhoun
Signature of Notary Public

of Surry County

State of North Carolina

My Commission Expires: 3/14/19

NOTARY SEAL

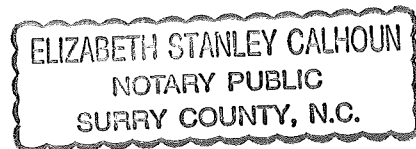

DEBARMENT CERTIFICATION

Conditions for certification:

1. The prequalified bidder shall provide immediate written notice to the Department if at any time the bidder learns that his certification was erroneous when he submitted his debarment certification or explanation filed with the Department, or has become erroneous because of changed circumstances.
2. The terms *covered transaction, debarred, suspended, ineligible, lower tier covered transaction, participant, person, primary covered transaction, principal, proposal, and voluntarily excluded*, as used in this provision, have the meanings set out in the Definitions and Coverage sections of the rules implementing Executive Order 12549. A copy of the Federal Rules requiring this certification and detailing the definitions and coverages may be obtained from the Contract Officer of the Department.
3. The prequalified bidder agrees by submitting this form, that he will not knowingly enter into any lower tier covered transaction with a person who is debarred, suspended, declared ineligible, or voluntarily excluded from participation in NCDOT contracts, unless authorized by the Department.
4. For Federal Aid projects, the prequalified bidder further agrees that by submitting this form he will include the Federal-Aid Provision titled *Required Contract Provisions Federal-Aid Construction Contract (Form FHWA PR 1273)* provided by the Department, without subsequent modification, in all lower tier covered transactions.
5. The prequalified bidder may rely upon a certification of a participant in a lower tier covered transaction that he is not debarred, suspended, ineligible, or voluntarily excluded from the covered transaction, unless he knows that the certification is erroneous. The bidder may decide the method and frequency by which he will determine the eligibility of his subcontractors.
6. Nothing contained in the foregoing shall be construed to require establishment of a system of records in order to render in good faith the certification required by this provision. The knowledge and information of a participant is not required to exceed that which is normally possessed by a prudent person in the ordinary course of business dealings.
7. Except as authorized in paragraph 6 herein, the Department may terminate any contract if the bidder knowingly enters into a lower tier covered transaction with a person who is suspended, debarred, ineligible, or voluntarily excluded from participation in this transaction, in addition to other remedies available by the Federal Government.

DEBARMENT CERTIFICATION

The prequalified bidder certifies to the best of his knowledge and belief, that he and his principals:

- a. Are not presently debarred, suspended, proposed for debarment, declared ineligible, or voluntarily excluded from covered transactions by any Federal department or agency;
- b. Have not within a three-year period preceding this proposal been convicted of or had a civil judgment rendered against them for commission of fraud or a criminal offense in connection with obtaining, attempting to obtain, or performing a public (Federal, State or local) transaction or contract under a public transaction; violation of Federal or State antitrust statutes or commission of embezzlement, theft, forgery, bribery, falsification or destruction of records; making false statements; or receiving stolen property;
- c. Are not presently indicted for or otherwise criminally or civilly charged by a governmental entity (Federal, State or local) with commission of any of the offenses enumerated in paragraph b. of this certification; and
- d. Have not within a three-year period preceding this proposal had one or more public transactions (Federal, State or local) terminated for cause or default.
- e. Will submit a revised Debarment Certification immediately if his status changes and will show in his bid proposal an explanation for the change in status.

If the prequalified bidder cannot certify that he is not debarred, he shall provide an explanation with this submittal. An explanation will not necessarily result in denial of participation in a contract.

Failure to submit a non-collusion affidavit and debarment certification will result in the prequalified bidder's bid being considered non-responsive.

Check here if an explanation is attached to this certification.

Contract No. C203725

County (ies): Forsyth

ACCEPTED BY THE
DEPARTMENT OF TRANSPORTATION

DocuSigned by:

A7679FC32A09476...
Contract Officer

5/16/2016

Date

Execution of Contract and Bonds
Approved as to Form:

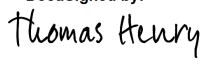
DocuSigned by:

03A0B0CC7724459...
Attorney General

5/16/2016

Date

Signature Sheet (Bid - Acceptance by Department)

**CERTIFICATION OF ELIGIBILITY
Under the Iran Divestment Act**

Pursuant to G.S. 147-86.59, any person identified as engaging in investment activities in Iran, determined by appearing on the Final Divestment List created by the State Treasurer pursuant to G.S. 147-86.58, is ineligible to contract with the State of North Carolina or any political subdivision of the State. The Iran Divestment Act of 2015, G.S. 147-55 *et seq.** requires that each vendor, prior to contracting with the State certify, and the undersigned on behalf of the Vendor does hereby certify, to the following:

1. that the vendor is not identified on the Final Divestment List of entities that the State Treasurer has determined engages in investment activities in Iran;
2. that the vendor shall not utilize on any contract with the State agency any subcontractor that is identified on the Final Divestment List; and
3. that the undersigned is authorized by the Vendor to make this Certification.

Vendor: Smith Rowe, LLC

By: David Locke Rowe

Signature

5/3/16

Date

David Locke Rowe

Printed Name

Manager

Title

The State Treasurer's Final Divestment List can be found on the State Treasurer's website at the address www.nctreasurer.com/Iran and will be updated every 180 days. For questions about the Department of State Treasurer's Iran Divestment Policy, please contact Meryl Murtagh at Meryl.Murtagh@nctreasurer.com or (919) 814-3852.

* Note: Enacted by Session Law 2015-118 as G.S. 143C-55 *et seq.*, but has been renumbered for codification at the direction of the Revisor of Statutes.

Contract No.
County

C203725

Forsyth

Rev 5-17-11

Bond No. 106503628

CONTRACT PAYMENT BOND

Date of Payment Bond Execution 05/03/16
Name of Principal Contractor Smith-Rowe, LLC
Name of Surety: Travelers Casualty and Surety Company of America
Name of Contracting Body: North Carolina Department of Transportation
Raleigh, North Carolina
Amount of Bond: \$11,693,639.31
Contract ID No.: C203725
County Name: Forsyth

KNOW ALL MEN BY THESE PRESENTS, That we, the PRINCIPAL CONTRACTOR (hereafter, PRINCIPAL) and SURETY above named, are held and firmly bound unto the above named Contracting Body, hereinafter called the Contracting Body, in the penal sum of the amount stated above for the payment of which sum well and truly to be made, we bind ourselves, our heirs, executors, administrators, and successors, jointly and severally, firmly by these presents.

THE CONDITION OF THIS OBLIGATION IS SUCH, that whereas the principal entered into a certain contract with the Contracting Body, numbered as shown above and hereto attached:

NOW THEREFORE, if the principal shall promptly make payment to all persons supplying labor and material in the prosecution of the work provided for in said contract, and any and all duly authorized modifications of said contract that may hereafter be made, notice of which modifications to the surety being hereby waived, then this obligation to be void; otherwise to remain in full force and virtue.

IN WITNESS WHEREOF, the above-bound parties have executed this instrument under their several seals on the date indicated above, the name and corporate seal of each corporate party being hereto affixed and these presents duly signed by its undersigned representative, pursuant to authority of its governing body.

Contract No.
County

C203725

Forsyth

Rev 5-17-11

CONTRACT PAYMENT BOND

Affix Seal of Surety Company

Travelers Casualty and Surety Company of America

Print or type Surety Company Name

By Jennifer C. Hoehn, Attorney-In-Fact

Print, stamp or type name of Attorney-in-Fact

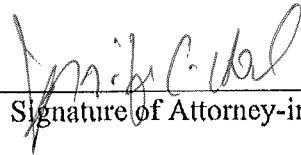

Signature of Attorney-in-Fact

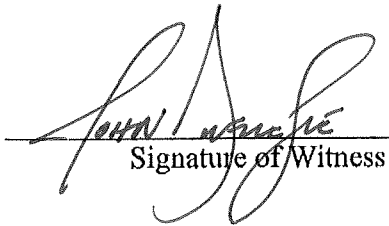

Signature of Witness



John Dufresne

Print or type Signer's name

C/O Wells Fargo Insurance Services USA, Inc.
P.O. Box 220748, Charlotte, NC 28222

Address of Attorney-in-Fact

Contract No.
County

C203725

Forsyth

Rev 5-17-11

CONTRACT PAYMENT BOND

LIMITED LIABILITY COMPANY

SIGNATURE OF CONTRACTOR (Principal)

Name of Contractor

Smith-Rowe, LLC

Full name of Firm

639 Old US 52 South, Mount Airy, NC 27030

Address as prequalified

By:



Signature of ~~Member~~, ~~Manager~~, ~~Authorized Agent~~
Select appropriate title

David L. Rowe

Print or type Signer's name



POWER OF ATTORNEY

Farmington Casualty Company
Fidelity and Guaranty Insurance Company
Fidelity and Guaranty Insurance Underwriters, Inc.
St. Paul Fire and Marine Insurance Company
St. Paul Guardian Insurance Company

St. Paul Mercury Insurance Company
Travelers Casualty and Surety Company
Travelers Casualty and Surety Company of America
United States Fidelity and Guaranty Company

Attorney-In Fact No. 230741

Certificate No. 006748061

KNOW ALL MEN BY THESE PRESENTS: That Farmington Casualty Company, St. Paul Fire and Marine Insurance Company, St. Paul Guardian Insurance Company, St. Paul Mercury Insurance Company, Travelers Casualty and Surety Company, Travelers Casualty and Surety Company of America, and United States Fidelity and Guaranty Company are corporations duly organized under the laws of the State of Connecticut, that Fidelity and Guaranty Insurance Company is a corporation duly organized under the laws of the State of Iowa, and that Fidelity and Guaranty Insurance Underwriters, Inc., is a corporation duly organized under the laws of the State of Wisconsin (herein collectively called the "Companies"), and that the Companies do hereby make, constitute and appoint

William J. Quinn, John D. Leak III, Jennifer C. Hoehn, John F. Thomas, Wendy M. Lands, and John Dufresne

of the City of Charlotte, State of North Carolina, their true and lawful Attorney(s)-in-Fact, each in their separate capacity if more than one is named above, to sign, execute, seal and acknowledge any and all bonds, recognizances, conditional undertakings and other writings obligatory in the nature thereof on behalf of the Companies in their business of guaranteeing the fidelity of persons, guaranteeing the performance of contracts and executing or guaranteeing bonds and undertakings required or permitted in any actions or proceedings allowed by law.

IN WITNESS WHEREOF, the Companies have caused this instrument to be signed and their corporate seals to be hereto affixed, this 26th day of April, 2016.

Farmington Casualty Company
Fidelity and Guaranty Insurance Company
Fidelity and Guaranty Insurance Underwriters, Inc.
St. Paul Fire and Marine Insurance Company
St. Paul Guardian Insurance Company

St. Paul Mercury Insurance Company
Travelers Casualty and Surety Company
Travelers Casualty and Surety Company of America
United States Fidelity and Guaranty Company



State of Connecticut
City of Hartford ss.

By: [Signature]
Robert L. Raney, Senior Vice President

On this the 26th day of April, 2016, before me personally appeared Robert L. Raney, who acknowledged himself to be the Senior Vice President of Farmington Casualty Company, Fidelity and Guaranty Insurance Company, Fidelity and Guaranty Insurance Underwriters, Inc., St. Paul Fire and Marine Insurance Company, St. Paul Guardian Insurance Company, St. Paul Mercury Insurance Company, Travelers Casualty and Surety Company, Travelers Casualty and Surety Company of America, and United States Fidelity and Guaranty Company, and that he, as such, being authorized so to do, executed the foregoing instrument for the purposes therein contained by signing on behalf of the corporations by himself as a duly authorized officer.

In Witness Whereof, I hereunto set my hand and official seal.
My Commission expires the 30th day of June, 2016.



[Signature]
Marie C. Tetreault, Notary Public

This Power of Attorney is granted under and by the authority of the following resolutions adopted by the Boards of Directors of Farmington Casualty Company, Fidelity and Guaranty Insurance Company, Fidelity and Guaranty Insurance Underwriters, Inc., St. Paul Fire and Marine Insurance Company, St. Paul Guardian Insurance Company, St. Paul Mercury Insurance Company, Travelers Casualty and Surety Company, Travelers Casualty and Surety Company of America, and United States Fidelity and Guaranty Company, which resolutions are now in full force and effect, reading as follows:

RESOLVED, that the Chairman, the President, any Vice Chairman, any Executive Vice President, any Senior Vice President, any Vice President, any Second Vice President, the Treasurer, any Assistant Treasurer, the Corporate Secretary or any Assistant Secretary may appoint Attorneys-in-Fact and Agents to act for and on behalf of the Company and may give such appointee such authority as his or her certificate of authority may prescribe to sign with the Company's name and seal with the Company's seal bonds, recognizances, contracts of indemnity, and other writings obligatory in the nature of a bond, recognizance, or conditional undertaking, and any of said officers or the Board of Directors at any time may remove any such appointee and revoke the power given him or her; and it is

FURTHER RESOLVED, that the Chairman, the President, any Vice Chairman, any Executive Vice President, any Senior Vice President or any Vice President may delegate all or any part of the foregoing authority to one or more officers or employees of this Company, provided that each such delegation is in writing and a copy thereof is filed in the office of the Secretary; and it is

FURTHER RESOLVED, that any bond, recognizance, contract of indemnity, or writing obligatory in the nature of a bond, recognizance, or conditional undertaking shall be valid and binding upon the Company when (a) signed by the President, any Vice Chairman, any Executive Vice President, any Senior Vice President or any Vice President, any Second Vice President, the Treasurer, any Assistant Treasurer, the Corporate Secretary or any Assistant Secretary and duly attested and sealed with the Company's seal by a Secretary or Assistant Secretary; or (b) duly executed (under seal, if required) by one or more Attorneys-in-Fact and Agents pursuant to the power prescribed in his or her certificate or their certificates of authority or by one or more Company officers pursuant to a written delegation of authority; and it is

FURTHER RESOLVED, that the signature of each of the following officers: President, any Executive Vice President, any Senior Vice President, any Vice President, any Assistant Vice President, any Secretary, any Assistant Secretary, and the seal of the Company may be affixed by facsimile to any Power of Attorney or to any certificate relating thereto appointing Resident Vice Presidents, Resident Assistant Secretaries or Attorneys-in-Fact for purposes only of executing and attesting bonds and undertakings and other writings obligatory in the nature thereof, and any such Power of Attorney or certificate bearing such facsimile signature or facsimile seal shall be valid and binding upon the Company and any such power so executed and certified by such facsimile signature and facsimile seal shall be valid and binding on the Company in the future with respect to any bond or understanding to which it is attached.

I, Kevin E. Hughes, the undersigned, Assistant Secretary, of Farmington Casualty Company, Fidelity and Guaranty Insurance Company, Fidelity and Guaranty Insurance Underwriters, Inc., St. Paul Fire and Marine Insurance Company, St. Paul Guardian Insurance Company, St. Paul Mercury Insurance Company, Travelers Casualty and Surety Company, Travelers Casualty and Surety Company of America, and United States Fidelity and Guaranty Company do hereby certify that the above and foregoing is a true and correct copy of the Power of Attorney executed by said Companies, which is in full force and effect and has not been revoked.

IN TESTIMONY WHEREOF, I have hereunto set my hand and affixed the seals of said Companies this 3 day of May, 2016.

WARNING: THIS POWER OF ATTORNEY IS INVALID WITHOUT THE RED BORDER

Kevin E. Hughes
Kevin E. Hughes, Assistant Secretary



To verify the authenticity of this Power of Attorney, call 1-800-421-3880 or contact us at www.travelersbond.com. Please refer to the Attorney-In-Fact number, the above-named individuals and the details of the bond to which the power is attached.



Contract No.
County

C203725

Forsyth

Rev 5-17-11

Bond No. 106503628

CONTRACT PERFORMANCE BOND

Date of Performance Bond Execution: 05/03/16
Name of Principal Contractor: Smith-Rowe, LLC
Name of Surety: Travelers Casualty and Surety Company of America
Name of Contracting Body: North Carolina Department of Transportation
Raleigh, North Carolina
Amount of Bond: \$11,693,639.31
Contract ID No.: C203725
County Name: Forsyth

KNOW ALL MEN BY THESE PRESENTS, That we, the PRINCIPAL CONTRACTOR (hereafter, PRINCIPAL) and SURETY above named, are held and firmly bound unto the above named Contracting Body, hereinafter called the Contracting Body, in the penal sum of the amount stated above for the payment of which sum well and truly to be made, we bind ourselves, our heirs, executors, administrators, and successors, jointly and severally, firmly by these presents.

THE CONDITION OF THIS OBLIGATION IS SUCH, that whereas the principal entered into a certain contract with the Contracting Body, numbered as shown above and hereto attached:

NOW THEREFORE, if the principal shall well and truly perform and fulfill all the undertakings, covenants, terms, conditions, and agreements of said contract during the original term of said contract and any extensions thereof that may be granted by the Contracting Body, with or without notice to the Surety, and during the life of any guaranty required under the contract, and shall also well and truly perform and fulfill all the undertakings, covenants, terms, conditions, and agreements of any and all duly authorized modifications of said contract that may hereafter be made, notice of which modifications to the surety being hereby waived, then this obligation to be void; otherwise to remain in full force and virtue.

IN WITNESS WHEREOF, the above-bound parties have executed this instrument under their several seals on the date indicated above, the name and corporate seal of each corporate party being hereto affixed and these presents duly signed by its undersigned representative, pursuant to authority of its governing body.

Contract No.
County

C203725

Forsyth

Rev 5-17-11

CONTRACT PERFORMANCE BOND

Affix Seal of Surety Company

Travelers Casualty and Surety Company of America

Print or type Surety Company Name

By Jennifer C. Hoehn, Attorney-In-Fact

Print, stamp or type name of Attorney-in-Fact

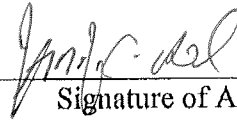

Signature of Attorney-in-Fact

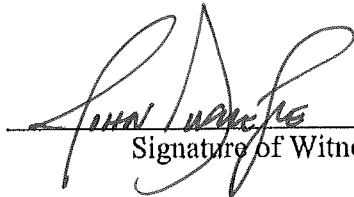

Signature of Witness

John Dufresne

Print or type Signer's name

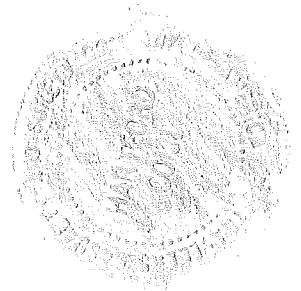

C/O Wells Fargo Insurance Services USA, Inc.
P.O. Box 220748, Charlotte, NC 28222

Address of Attorney-in-Fact

Contract No.
County

C203725

Forsyth

Rev 5-17-11

CONTRACT PERFORMANCE BOND

LIMITED LIABILITY COMPANY

SIGNATURE OF CONTRACTOR (Principal)

Name of Contractor

Smith-Rowe, LLC

Full name of Firm

639 Old US 52 South, Mount Airy, NC 27030

Address as prequalified

By:



Signature of ~~Member, Manager, Authorized Agent~~
Select appropriate title

David L. Rowe

Print or type Signer's name



POWER OF ATTORNEY

Farmington Casualty Company
Fidelity and Guaranty Insurance Company
Fidelity and Guaranty Insurance Underwriters, Inc.
St. Paul Fire and Marine Insurance Company
St. Paul Guardian Insurance Company

St. Paul Mercury Insurance Company
Travelers Casualty and Surety Company
Travelers Casualty and Surety Company of America
United States Fidelity and Guaranty Company

Attorney-In Fact No. 230741

Certificate No. 006748063

KNOW ALL MEN BY THESE PRESENTS: That Farmington Casualty Company, St. Paul Fire and Marine Insurance Company, St. Paul Guardian Insurance Company, St. Paul Mercury Insurance Company, Travelers Casualty and Surety Company, Travelers Casualty and Surety Company of America, and United States Fidelity and Guaranty Company are corporations duly organized under the laws of the State of Connecticut, that Fidelity and Guaranty Insurance Company is a corporation duly organized under the laws of the State of Iowa, and that Fidelity and Guaranty Insurance Underwriters, Inc., is a corporation duly organized under the laws of the State of Wisconsin (herein collectively called the "Companies"), and that the Companies do hereby make, constitute and appoint

William J. Quinn, John D. Leak III, Jennifer C. Hoehn, John F. Thomas, Wendy M. Lands, and John Dufresne

of the City of Charlotte, State of North Carolina, their true and lawful Attorney(s)-in-Fact, each in their separate capacity if more than one is named above, to sign, execute, seal and acknowledge any and all bonds, recognizances, conditional undertakings and other writings obligatory in the nature thereof on behalf of the Companies in their business of guaranteeing the fidelity of persons, guaranteeing the performance of contracts and executing or guaranteeing bonds and undertakings required or permitted in any actions or proceedings allowed by law.

IN WITNESS WHEREOF, the Companies have caused this instrument to be signed and their corporate seals to be hereto affixed, this 26th day of April, 2016.

Farmington Casualty Company
Fidelity and Guaranty Insurance Company
Fidelity and Guaranty Insurance Underwriters, Inc.
St. Paul Fire and Marine Insurance Company
St. Paul Guardian Insurance Company

St. Paul Mercury Insurance Company
Travelers Casualty and Surety Company
Travelers Casualty and Surety Company of America
United States Fidelity and Guaranty Company



State of Connecticut
City of Hartford ss.

By: [Signature]
Robert L. Raney, Senior Vice President

On this the 26th day of April, 2016, before me personally appeared Robert L. Raney, who acknowledged himself to be the Senior Vice President of Farmington Casualty Company, Fidelity and Guaranty Insurance Company, Fidelity and Guaranty Insurance Underwriters, Inc., St. Paul Fire and Marine Insurance Company, St. Paul Guardian Insurance Company, St. Paul Mercury Insurance Company, Travelers Casualty and Surety Company, Travelers Casualty and Surety Company of America, and United States Fidelity and Guaranty Company, and that he, as such, being authorized so to do, executed the foregoing instrument for the purposes therein contained by signing on behalf of the corporations by himself as a duly authorized officer.

In Witness Whereof, I hereunto set my hand and official seal.
My Commission expires the 30th day of June, 2016.



[Signature]
Marie C. Tetreault, Notary Public

This Power of Attorney is granted under and by the authority of the following resolutions adopted by the Boards of Directors of Farmington Casualty Company, Fidelity and Guaranty Insurance Company, Fidelity and Guaranty Insurance Underwriters, Inc., St. Paul Fire and Marine Insurance Company, St. Paul Guardian Insurance Company, St. Paul Mercury Insurance Company, Travelers Casualty and Surety Company, Travelers Casualty and Surety Company of America, and United States Fidelity and Guaranty Company, which resolutions are now in full force and effect, reading as follows:

RESOLVED, that the Chairman, the President, any Vice Chairman, any Executive Vice President, any Senior Vice President, any Vice President, any Second Vice President, the Treasurer, any Assistant Treasurer, the Corporate Secretary or any Assistant Secretary may appoint Attorneys-in-Fact and Agents to act for and on behalf of the Company and may give such appointee such authority as his or her certificate of authority may prescribe to sign with the Company's name and seal with the Company's seal bonds, recognizances, contracts of indemnity, and other writings obligatory in the nature of a bond, recognizance, or conditional undertaking, and any of said officers or the Board of Directors at any time may remove any such appointee and revoke the power given him or her; and it is

FURTHER RESOLVED, that the Chairman, the President, any Vice Chairman, any Executive Vice President, any Senior Vice President or any Vice President may delegate all or any part of the foregoing authority to one or more officers or employees of this Company, provided that each such delegation is in writing and a copy thereof is filed in the office of the Secretary; and it is

FURTHER RESOLVED, that any bond, recognizance, contract of indemnity, or writing obligatory in the nature of a bond, recognizance, or conditional undertaking shall be valid and binding upon the Company when (a) signed by the President, any Vice Chairman, any Executive Vice President, any Senior Vice President or any Vice President, any Second Vice President, the Treasurer, any Assistant Treasurer, the Corporate Secretary or any Assistant Secretary and duly attested and sealed with the Company's seal by a Secretary or Assistant Secretary; or (b) duly executed (under seal, if required) by one or more Attorneys-in-Fact and Agents pursuant to the power prescribed in his or her certificate or their certificates of authority or by one or more Company officers pursuant to a written delegation of authority; and it is

FURTHER RESOLVED, that the signature of each of the following officers: President, any Executive Vice President, any Senior Vice President, any Vice President, any Assistant Vice President, any Secretary, any Assistant Secretary, and the seal of the Company may be affixed by facsimile to any Power of Attorney or to any certificate relating thereto appointing Resident Vice Presidents, Resident Assistant Secretaries or Attorneys-in-Fact for purposes only of executing and attesting bonds and undertakings and other writings obligatory in the nature thereof, and any such Power of Attorney or certificate bearing such facsimile signature or facsimile seal shall be valid and binding upon the Company and any such power so executed and certified by such facsimile signature and facsimile seal shall be valid and binding on the Company in the future with respect to any bond or understanding to which it is attached.

I, Kevin E. Hughes, the undersigned, Assistant Secretary, of Farmington Casualty Company, Fidelity and Guaranty Insurance Company, Fidelity and Guaranty Insurance Underwriters, Inc., St. Paul Fire and Marine Insurance Company, St. Paul Guardian Insurance Company, St. Paul Mercury Insurance Company, Travelers Casualty and Surety Company, Travelers Casualty and Surety Company of America, and United States Fidelity and Guaranty Company do hereby certify that the above and foregoing is a true and correct copy of the Power of Attorney executed by said Companies, which is in full force and effect and has not been revoked.

IN TESTIMONY WHEREOF, I have hereunto set my hand and affixed the seals of said Companies this 3 day of May, 2016

WARNING: THIS POWER OF ATTORNEY IS INVALID WITHOUT THE RED BORDER

Kevin E. Hughes
Kevin E. Hughes, Assistant Secretary



To verify the authenticity of this Power of Attorney, call 1-800-421-3880 or contact us at www.travelersbond.com. Please refer to the Attorney-In-Fact number, the above-named individuals and the details of the bond to which the power is attached.

